

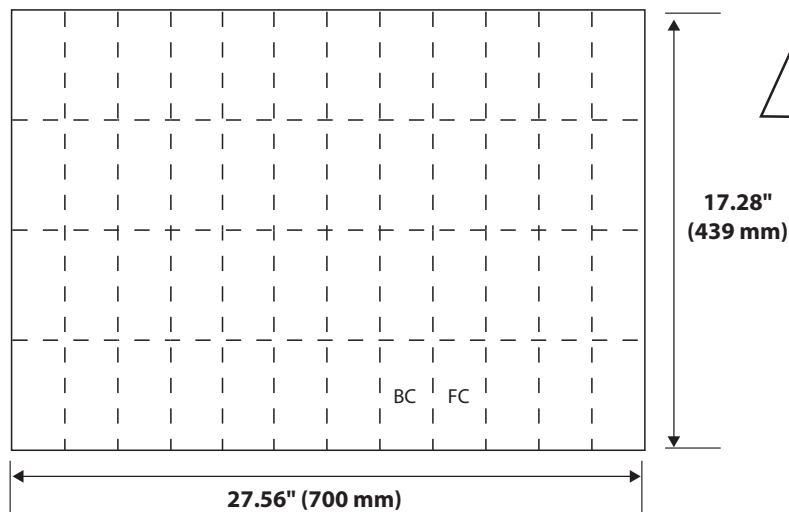

### IFU PRINTING SPECIFICATION SHEET

#### PAGE LAYOUT



Flat Size

#### FOLD PATTERN

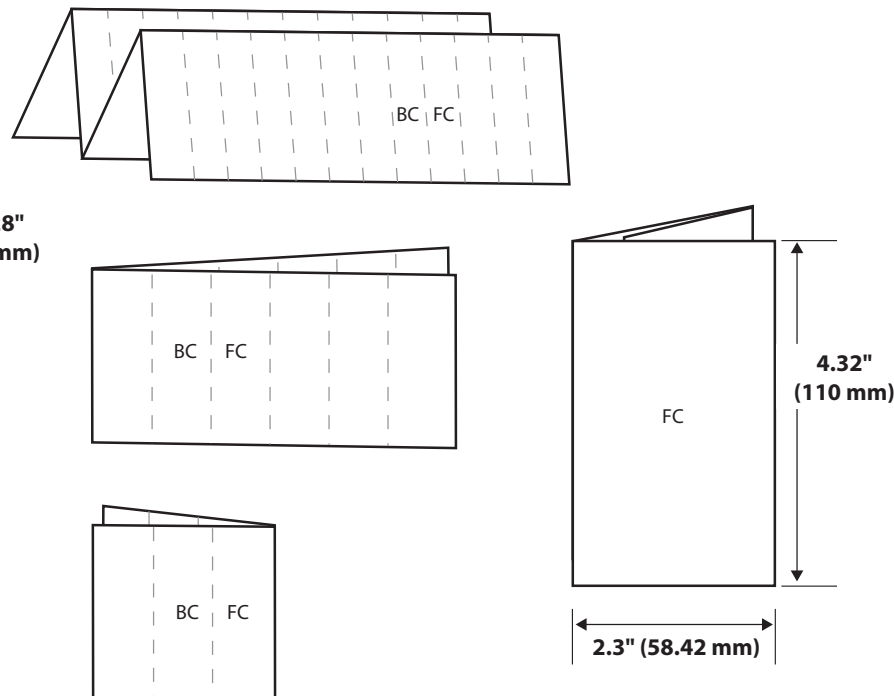

Folded Size

TITLE <b>ETHILON™</b>		DESCRIPTION <b>Map IFU</b>		LAB NUMBER <b>LAB100601593v2</b>	SPECIAL INSTRUCTIONS/COMMENTS n/a			BINDING n/a	COLORS <b>Black</b>		
FLAT SIZE <b>27.56" x 17.28"</b> <b>700 mm x 439 mm</b>		FOLDED SIZE <b>2.3" x 4.32"</b> <b>58.42 mm x 110 mm</b>		RMC NUMBER <b>390323R02</b>	PAGE COUNT <b>2</b>		LANGUAGES <b>ar, cs, da, de, el, en, es, fi, fr, hu, it, kk, ko, nl, no, pl, pt, ro, ru, sk, sv, tr, zh-cn, zh-tw</b>	SELF COVER <input checked="" type="checkbox"/>	PLUS COVER <input type="checkbox"/>	SEALING METHOD <input type="checkbox"/>	WAFER SEAL <input checked="" type="checkbox"/>
BLEED SIZE .5" (12.7 mm) <input type="checkbox"/> .125" (3.175 mm) <input type="checkbox"/>		NONE <input checked="" type="checkbox"/> BLEED ALL SIDES <input type="checkbox"/>		BLEED TOP <input type="checkbox"/>	BLEED RIGHT <input type="checkbox"/>	BLEED LEFT <input type="checkbox"/>	BLEED BOTTOM <input type="checkbox"/>	<b>DRAWING IS NOT TO SCALE:</b> DRAWINGS REFLECT INFORMATION FOR PRODUCTION OF PRINTED PIECES AND DO NOT CONTAIN ACTUAL ARTWORK. This document or data herein or herewith is not to be reproduced, used or disclosed in whole or part without the permission of Ethicon, Inc.			
STOCK Refer to MS159-007					<b>ETHICON</b>						