

# Coated VICRYL™ PLUS – ANTIBACTERIAL – SUTURE

ro FIR DE SUTURĂ  
ru ШОВНИЙ МАТЕРІАЛ  
sk CHIRURGICKÁ NIŤ  
sl KIRURŠKA NIŤ  
sr KONAC  
sv SUTUR  
tr SÜTÜR  
zh-cn 縫線  
zh-tw 縫合線

hr KONAC  
hu VARRÓANYAG  
it SUTURA  
ko 봉합사  
lt SULAS  
lv KIRURĢSKAIS DIEGS  
ni HECHTRAAD  
no SUTUR  
pl NICI  
pt FIODE SUTURA

bg КОВЕЦ  
cs SÍČI MATERIÁL  
da SUTUR  
de NAHTMATERIAL  
el ΠΑΥΜΑ  
en SUTURE  
es SUTURA  
et ÕMBLUSMATERJAL  
fi OMMELAINE  
fr FIL DE SUTURE

 **ЭТИКОН-ЭТИКОН INTERNATIONAL**  
c/o European Logistics Centre  
Leonardo Da Vinci laan, 15  
BE-1831 Diegem  
Belgium  
1-877-ETHICON  
+1-513-337-6928



08/2019  
LAB0012862v7



## Instructions for use Coated VICRYL™ PLUS ANTIBACTERIAL (POLYLACTIN 910) STERILE SYNTHETIC ABSORBABLE SUTURE

**DESCRIPTION**  
Coated VICRYL™ PLUS Antibacterial suture is a synthetic absorbable sterile surgical suture composed of a copolymer made from 90 % glycolide and 10 % L-lactide. The empirical formula of the copolymer is (C<sub>12</sub>H<sub>16</sub>O<sub>5</sub>)<sub>x</sub>(C<sub>8</sub>H<sub>10</sub>O<sub>3</sub>)<sub>y</sub>.  
Braided Coated VICRYL™ PLUS Antibacterial sutures are coated with a mixture composed of equal parts of copolymer of glycolide and lactide (Polylactin 370) and calcium stearate. Polylactin 910 copolymer and Polylactin 370 with calcium stearate have been found to be nonantigenic, nonpyrogenic and elicit only a slight tissue reaction during absorption.  
Coated VICRYL™ PLUS Antibacterial suture contains Irgacare™ MP (Triclosan), a broad spectrum antibacterial agent at no more than 275 µg/m.  
Coated VICRYL™ PLUS Antibacterial sutures are dyed by adding D+C violet # 2 (Color Index number: 60725) during polymerization. Sutures are also available in the undyed form.  
Coated VICRYL™ PLUS Antibacterial sutures are available in a range of gauge sizes and lengths, non-needled or attached to stainless steel needles of varying types and sizes. The needles may be attached permanently or as CR-needles (control release), enabling the needles to be pulled off instead of being cut off. Full details are contained in the catalogue.  
Coated VICRYL™ PLUS Antibacterial sutures comply with the requirements of the United States Pharmacopoeia for Absorbable Surgical Suture and the European Pharmacopoeia for Sterile Synthetic Absorbable Braided Sutures (except for an occasional slight oversize in some gauges).  
Coated VICRYL™ PLUS Antibacterial sutures are intended for use in general soft tissue approximation and/or ligation. The safety and effectiveness of Coated VICRYL™ PLUS Antibacterial sutures in cardiovascular tissue, ophthalmic surgery and neurological tissue have not been established.

**INDICATIONS**  
Sutures should be selected and implanted depending on patient condition, surgical experience, surgical technique and wound size.

**PERFORMANCE**  
Coated VICRYL™ PLUS Antibacterial suture elicits a minimal initial inflammatory reaction in tissues and ingrowth of fibrous connective tissue. Progressive loss of tensile strength and eventual absorption of Coated VICRYL™ PLUS Antibacterial sutures occurs by means of hydrolysis, where the copolymer degrades to glycolic and lactic acids which are subsequently absorbed and metabolized in the body. Absorption begins as a loss of tensile strength followed by a loss of mass. All of the original tensile strength is lost by five weeks post implantation. Absorption of Coated VICRYL™ PLUS Antibacterial suture is essentially complete between 56 and 70 days.

Days Implantation	Approximate % Original Strength Remaining
14 days	75%
21 days	50%
28 days	25%

Coated VICRYL™ PLUS Antibacterial suture has been shown to inhibit colonization of the suture by *Staphylococcus aureus*, *Staphylococcus epidermidis* and their Methicillin resistant strains. The clinical significance of this finding is unknown.

**CONTRAINDICATIONS**  
These sutures, being absorbable should not be used where extended approximation of tissues under stress is required. Coated VICRYL™ PLUS Antibacterial suture should not be used in patients with known allergic reactions to Irgacare™ MP (Triclosan).

**WARNINGS/PRECAUTIONS/INTERACTIONS**  
Users should be familiar with surgical procedures and techniques involving absorbable sutures before employing Coated VICRYL™ PLUS Antibacterial suture for wound closure, as risk of wound dehiscence may vary with the site of application and the suture material used. Surgeons should consider the in vivo performance (under PERFORMANCE section) when selecting a suture.  
As with any foreign body, prolonged contact of any suture with salt solutions, such as those found in the urinary or biliary tracts, may result in calculus formation. As an absorbable suture Coated VICRYL™ PLUS Antibacterial suture may act transiently as a foreign body.  
Acceptable surgical practice should be followed for the management of contaminated or infected wounds.  
The use of Coated VICRYL™ PLUS Antibacterial suture does not substitute normal observation of hygiene and/or otherwise needed antibiotic treatment.  
As this is an absorbable suture material, the use of supplemental nonabsorbable sutures should be considered by the surgeon in the closure of the sites which may undergo expansion, stretching or distension, or which may require additional support.  
Skin sutures which must remain in place longer than 7 days may cause localised irritation and should be snipped off or removed as indicated.  
Under some circumstances, notably orthopaedic procedures, immobilisation of joints by external support may be employed at the discretion of the surgeon.  
Consideration should be taken in the use of absorbable sutures in tissues with poor blood supply as suture extrusion and delayed absorption may occur. Subcuticular sutures should be placed as deeply as possible to minimize the erythema and induration normally associated with the absorption process.  
This suture may be inappropriate in elderly, malnourished or debilitated patients, or in patients suffering from conditions which may delay wound healing.  
When handling this or any other suture material, care should be taken to avoid damage. Avoid crushing or crimping damage due to application of surgical instruments such as forceps or needle holders.  
Care should be taken to avoid damage when handling surgical needles. Grasp the needle in an area one-third (1/3) to one-half (1/2) of the distance from the attachment end to the point. Grasping in the point area could impair the penetration performance and cause fracture of the needle. Grasping at the butt or attachment end could cause











bending or breakage. Reshaping needles may cause them to lose strength and be less resistant to bending and breaking.  
Users should exercise caution when handling surgical needles to avoid inadvertent needle stick injury. Discard used needles in Sharps containers.  
Adequate knot security requires the standard surgical technique of flat and square ties with additional throws as indicated by surgical circumstances and the experience of the surgeon.  
Do not resterilize/reuse. Reuse of this device (or portions of this device) may create a risk of product degradation and cross-contamination, which may lead to infection or transmission of bloodborne pathogens to patients and users.

**ADVERSE REACTIONS**  
Adverse reactions associated with the use of this device include transitory local irritation at the wound site, transitory inflammatory foreign body response, erythema and induration during the absorption process of subcuticular sutures. Like all foreign bodies Coated VICRYL™ PLUS Antibacterial suture may potentiate an existing infection.

**STERILITY**  
Coated VICRYL™ PLUS Antibacterial sutures are sterilized by ethylene oxide gas. Do not resterilize. Do not use if package is opened or damaged. Discard opened, unused sutures.

**STORAGE**  
Recommended storage conditions: Store at or below 25°C. Do not use after expiry date.

**SYMBOLS USED ON LABELING**

	Do not reuse		Use by – year and month
	Sterile unless package is damaged or opened. Method of sterilization: Ethylene Oxide		Manufacturer
	CE-mark and Identification Number of Notified Body. The product meets the essential requirements of Medical Device Directive 93/42/EEC		Sachets
	Upper limit of temperature		Catalogue Number
	Caution: See instructions for use		Batch number

† = Registered Trademark of BASF Group

THIS PANEL IS LEFT BLANK INTENTIONALLY.

THIS PANEL IS LEFT BLANK INTENTIONALLY.

### IFU PRINTING SPECIFICATION SHEET

#### PAGE LAYOUT

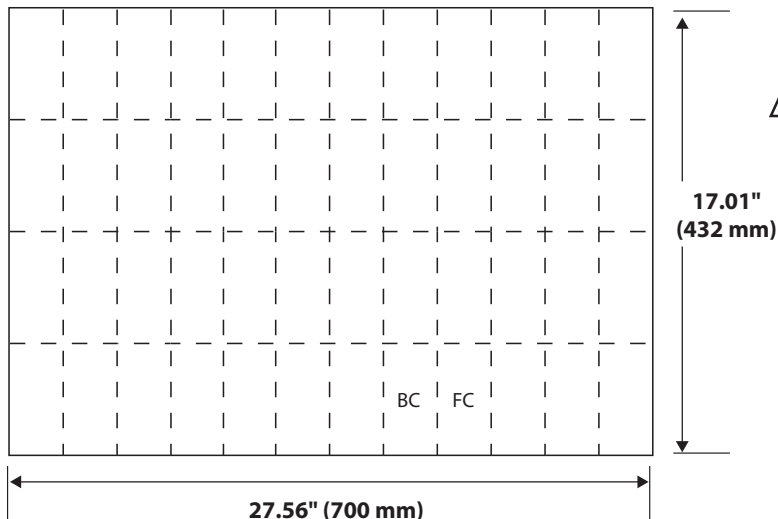

27.56" (700 mm)

17.01"  
(432 mm)

Flat Size

#### FOLD PATTERN

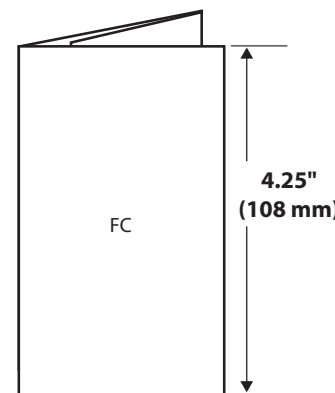
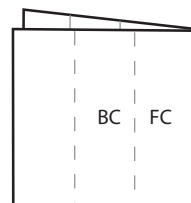
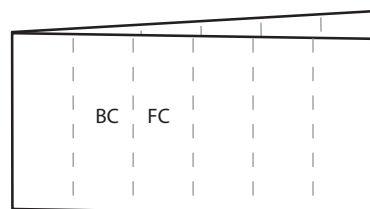
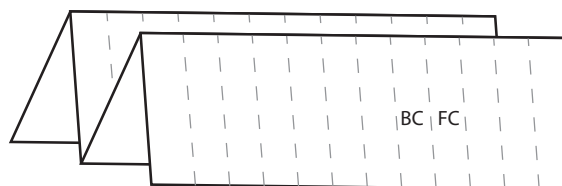

4.25"  
(108 mm)

2.30" (58.33 mm)

Folded Size

TITLE <b>VICRYL™ PLUS</b>		DESCRIPTION <b>Map IFU</b>		LAB NUMBER <b>LAB0012862v7</b>		SPECIAL INSTRUCTIONS/COMMENTS <b>See Norderstedt RMS VPP833AUE and VPP833A for Tolerance and packaging requirements.</b>		BINDING <b>Folded</b>		COLORS <b>Black</b>			
FLAT SIZE <b>27.56" x 17.01"</b> <b>700 mm x 432 mm</b>		FOLDED SIZE <b>2.30" x 4.25"</b> <b>58.33 mm x 108 mm</b>		RMC NUMBER <b>8752635</b>	PAGE COUNT <b>2</b>	LANGUAGES <b>bg, cs, da, de, el, en, es, et, fi, fr, hr, hu, it, ko, lt, lv, nl, no, pl, pt, ro, ru, sk, sl, sr, sv, tr, zh-cn, zh-tw</b>				SELF COVER <input checked="" type="checkbox"/>	PLUS COVER <input type="checkbox"/>	SEALING METHOD <b>N/A</b>	WAFER SEAL <input type="checkbox"/>
BLEED SIZE <b>.5" (12.7 mm)</b> <input type="checkbox"/> <b>.125" (3.175 mm)</b> <input checked="" type="checkbox"/>		NONE <input type="checkbox"/>	BLEED ALL SIDES <input type="checkbox"/>	BLEED TOP <input type="checkbox"/>	BLEED RIGHT <input checked="" type="checkbox"/>	BLEED LEFT <input checked="" type="checkbox"/>	BLEED BOTTOM <input type="checkbox"/>	<b>DRAWING IS NOT TO SCALE: DRAWINGS REFLECT INFORMATION FOR PRODUCTION OF PRINTED PIECES AND DO NOT CONTAIN ACTUAL ARTWORK.</b> This document or data herein or herewith is not to be reproduced, used or disclosed in whole or part without the permission of Ethicon, Inc.					
STOCK <b>45 g/m<sup>2</sup></b>						<b>ETHICON</b>							