



**ri-former®**

**Gebrauchsanweisung**

**Instruction for use**

**Instructions d'utilisation**

**Instrucciones de uso**

**Istruzioni per l'uso**

**Инструкция по эксплуатации**

CE

 **Riester**

## Table of Content













1.	Introduction
1.1.	Important Information read prior to Start-up
1.2.	Safety Symbols
1.3.	Packaging Symbols
1.4.	Intended Use
1.4.1	Indication
1.4.2	Contraindication
1.4.3	Intended patient population
1.4.4	Intended operators / users
1.4.5	Required skills / training of operators
1.4.6	Environmental conditions
1.5.	Warnings / Attention
1.6.	User Responsibility
2.	Using the Device for the first time
2.1.	Scope of Supply
2.2.	Device Function
3.	Operation and Function
3.1.	Attachment
3.2.	Icon Identification
3.3.	Commissioning
3.4.	ri-former® mobile
3.5.	ri-former® Anesthesia
4.	Cleaning and Disinfection
4.1.	General Information
4.2.	Cleaning and Disinfection
5.	Technical Data
6.	ri-scope®L Instrument heads / ri-scope Instrument heads
6.1.	ri-scope®L otoscope
6.2.	ri-scope®L ophthalmoscopes
6.3.	Slit and spot retinoscopes
6.4.	Dermatoscope
6.5.	Bent-arm illuminator
6.6.	Nasal specula
6.7.	Tongue depressor
6.8.	Laryngeal mirror
6.9.	Operation otoscope for veterinary medicine
6.10.	Operation otoscope for human medicine
7.	Replacing the lamp Otoloscope L1
7.1.	Otoscopes L2, L3, ri-derma, lamp holder, nasal specula and depressor holder
7.2.	Ophthalmoscopes
8.	Care instructions
8.1.	General note
8.2.	Cleaning and disinfecting
8.3.	Sterilisation
9.	Spare parts and accessories
10.	Electromagnetic Compatibility accompanying Documents according to IEC 60601-1-2
10.1.	EMC (electromagnetic compatibility)
11.	Accessories
12.	Disposal
13.	Warranty









## 1. Introduction

### 1.1. Important Information read prior to Start-up





You have purchased a high quality Riester **ri-former®** Diagnostic Station, which has been manufactured according to the Regulation (EU) 2017/745 and is subject to the strictest quality controls at all times. Read these instructions for use carefully before putting the unit into operation and keep them in a safe place. If you should have any questions, we are available to answer queries at all times. Our address can be found in these instructions for use. The address of our sales partner will be given upon request. Please note that all instruments described in these instructions for use are only to be used by suitably trained personnel. The perfect and safe functioning of this device is only guaranteed when original parts and accessories from Riester are used.

### 1.2. Safety Symbols

Symbol	Symbol Note
	Follow the instructions in the operation manual. The symbol is printed in black color on the probe cover box. The symbol is printed in blue color on the device.
	Medical Device
	Type B applied part
	Protection class II devices
	Warning! The general warning sign indicates a potentially hazardous situation which could result in serious injury. (Background color yellow, foreground color black)
	Attention! Important note in this instruction use. The attention symbol indicates a potentially hazardous situation which may result in minor or moderate injury. It may also be used to alert against unsafe practices
	Direct current
	Alternating current
	Caution: Federal (USA) law restricts this device to sale by or on the order of a physician (licensed healthcare practitioner).
	Manufacturing date YYYY-MM-DD / (Year-Month-Day)
	Manufacturer
	Manufacturer serial number
	Lot number

	Reference number
	Temperature for transport and storage condition
	Relative Humidity for transport and storage condition
	Air pressure for transport and storage Air pressure for Ambient Operating
	CE Mark
	Symbol for the marking of electrical and electronics devices according to Directive 2002/96/EC.
	Non-ionizing radiation
	Maximum weight of the basket can bear < 1,5 kg
	Final maximum weight of whole device including mobile stand, <b>ri-former</b> <sup>®</sup> Diagnostic Station, big-ben and basket bear and basket bear the max. weight. 13 kg

### 1.3. Packaging Symbols

Symbol	Symbol Note
	Fragile. Show transport package contents fragile, so handling should be handled with care.
	Beware the package from getting wet.
	Upward. It shows the correct position to transport the package.
	Keep away from sunlight
	„Grüner Punkt“ (country-specific)

The device satisfies the requirements for electromagnetic compatibility. Please note that under the influence of unfavorable field strengths, e.g. during the operation of wireless telephones or radiological instruments, adverse effects on function cannot be excluded. The electromagnetic compatibility of this device has been verified by test according to the IEC 60601-1-2 requirements

### 1.4 Intended Use

The **ri-former**<sup>®</sup> Diagnostic Station was manufactured for use with various instrument heads and modular components for non-invasive diagnostics.

#### 1.4.1 Indication

The **ri-former**<sup>®</sup> Diagnostic Station supplies the different instrument heads and modular components with energy. The various instruments, extension modules connected to the diagno-

stic Station, serve the trained physician or specialist as an aid in the detection, diagnosis, monitoring, treatment o. Alleviation of illnesses, injuries or disabilities.

#### 1.4.2 Contraindication

The device is not designed, sold, or intended for use except as indicated.

#### 1.4.3 Intended patient population

The device is intended for all patients.

#### 1.4.4 Intended operators / users

The device could be used by a doctor, nurse in hospitals, medical facilities, clinics, doctors' offices. No use in MR environment!

#### 1.4.5 Required skills / training of operators











The operators have the appropriate qualification for the use of this diagnostic tool. All connectors and connections are clearly explained in the instructions for use.







The user must comply exactly with the instructions in the instructions for use.

#### 1.4.6 Environmental conditions

The device is determined to be used in a controlled environment . The device must not be exposed to harsh / rough environmental conditions.

### 1.5 Warnings / Attention

	Warnings!: The general warning sign indicates a potentially hazardous situation which could result in serious injury.
	No use in MR environment!
	There is a possible danger of inflammation of gases if the device is operated in the presence of inflammatory mixtures or mixtures of pharmaceuticals and air or oxygen or laughing gas! / The appliance shall not be operated in premises where inflammatory mixtures or mixtures of pharmaceuticals and air or oxygen or laughing gas are present, e.g. Operating rooms.
	Electric shock! The <b>ri-former</b> <sup>®</sup> Diagnostic Station housing may only be opened by authorized persons
	Damage to the device due to falling, or to high ESD influence! If the device has no function, it must be returned to the manufacturer for repair.
	The device is to determine to be used in a controlled environment. The device must not be exposed to harsh / rough environmental conditions.
	Using the Otoskope to a new earspecula.
	A maximum of 2 handles may be used at the same time, otherwise the wide-range power supply may be overloaded.
	- Disposable ear specula Only use new ear specula to limit the risk of cross contamination. - Reusable ear specula Only use cleaned / sterilized ear specula to limit the risk of cross contamination.
	To limit the risk of cross-contamination, only use a cleaned, disinfected nasal specula.

	The device and Ear specula are non-sterile. Do not use on abraded tissue.
	The otoscope with LED lighting is not suitable for eye examination. There is a risk of eye damage!
	<b>Attention!</b> The caution symbol indicates a potentially hazardous situation which may result in minor or moderate injury. It may also be used to alert against unsafe practices.
	The perfect and safe functioning of this instrument is only guaranteed when original parts and accessories from Riester are used.
	Cleaning frequency and practices must be consistent with institutional policy for cleaning of non-sterile devices.
	<ul style="list-style-type: none"> <li>- We recommend disconnecting the power adapter of the ri-former® Diagnostic Station from the power supply before cleaning or disinfection.</li> <li>- Be careful when cleaning and disinfecting the ri-former® diagnosis Station so that no liquid penetrates into the interior.</li> <li>- Never put detachable parts of the ri-former® diagnosis station and extension modules (spiral cable / handle / instrument heads) in liquids!</li> <li>- The ri-former® diagnostic Station / instrument heads are supplied non-sterile. DO NOT use ethylene, oxide gas, heat, autoclave, or other harsh methods to sterilize the device.</li> <li>- The devices / instruments have not been released for machine reprocessing and sterilization. This leads to irreparable damage!</li> <li>- The disposable ear specula is only suitable for single use!</li> </ul>
	Any serious incident that has occurred in relation to the device should be reported to the manufacturer and the competent authority of the Member State in which the user and/or patient is established.



## 2. Using the Device for the first time

### 2.1 Scope of Supply



Art. No.: 3650	<b>ri-former® 1</b> handle with clock 3,5 V/100-240 V - User Manual - Wall mounting material - Drilling plan
Art. No.: 3652	<b>ri-former® 1</b> handle without clock 3,5 V/100-240 V - User Manual - Wall mounting material - Drilling plan
Art. No.: 3650-300	<b>ri-former® 2</b> handle with clock 3,5 V/100-240 V - User Manual - Wall mounting material - Drilling plans
Art. No.: 3652-300	<b>ri-former® 2</b> handle without clock 3,5 V/100-240 V - User Manual - Wall mounting material - Drilling plans

### 2.2 Device Function

The **ri-former®** Diagnostic Station was made with various instruments for operating heads and modular components for non-invasive diagnosis.

<b>ri-former®</b> Diagnostic Station	<b>ri-former®</b> Diagnostic Station with Extension Module
	
<ol style="list-style-type: none"> <li>1. <b>ri-former®</b> Diagnostic Station</li> <li>2. Optional clock</li> <li>3. ON- OFF Rocker switch with green control lamp</li> <li>4. Application part / Handle with rheotronic®</li> <li>5. Switching ring on the handle</li> <li>6. Handle head</li> <li>7. Extension Module</li> </ol>	

### 1.6 User Responsibility

	<p><b>Attention!</b> User Responsibility It is your responsibility to:</p> <ul style="list-style-type: none"> <li>- Before each use, the user must check the integrity and completeness of the ri-former® Diagnostic Station / Extension Module / Instruments head. All components must be compatible with each other.</li> <li>- Incompatible components can result in degraded performance.</li> <li>- Never knowingly use a defective device.</li> <li>- Immediately replace parts that are broken, worn, missing, incomplete, damaged or contaminated.</li> <li>- Contact the nearest factory approved service center should repair or replacement become necessary.</li> <li>- Further, the user of the device bears sole responsibility for any malfunction that results from improper use, faulty maintenance, improper repair, damage or alteration by anyone other than Riester or authorized service personnel.</li> </ul>
	Any serious incident that has occurred in relation to the device should be reported to the manufacturer and the competent authority of the Member State in which the user and/or patient is established.

## 3. Operation and Function

### 3.1 Attachment

#### 3.1.1 Drilling plan

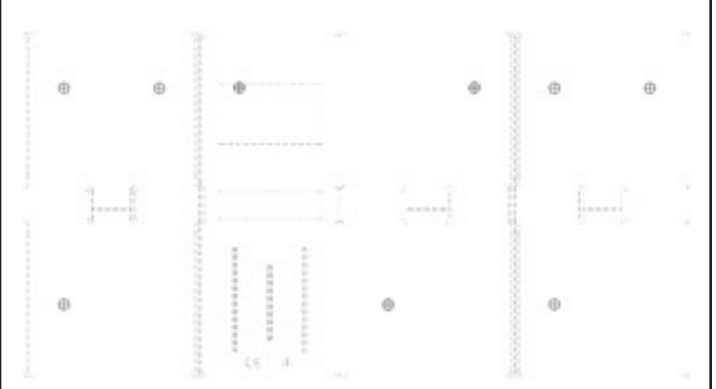

#### 3.1.2 Drilling instructions/drilling plan

The drilling instructions and the drilling plan are enclosed separately. Follow the drilling instructions in order to drill the holes in the wall.

### 3.1.3 Attaching the wall mounting plates

After you have drilled the holes, take the plugs supplied and push them into the holes as far they will go. Take the wall mounting plate and hold it onto the wall so that the screws can be pushed through the holes of the mounting plate into the plugs. Now screw in the screws with a screw driver, as far as they will go.

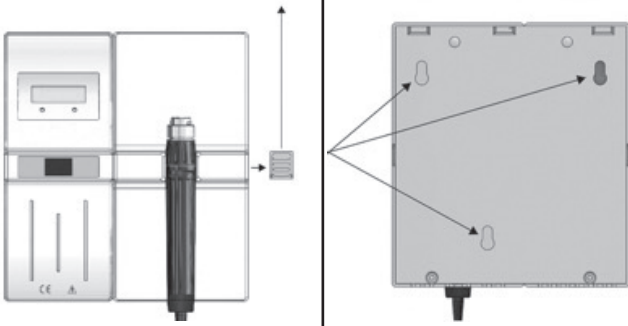

### 3.1.4 Attachment of the diagnostic station

When all screws have been screwed in tightly, take the diagnostic station and guide the screw heads through the openings. Remove the sliding cover of the diagnostic station. Then press the diagnostic station downwards until it snaps into place.

a)

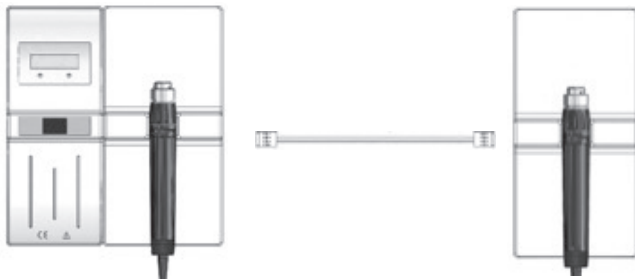

b)

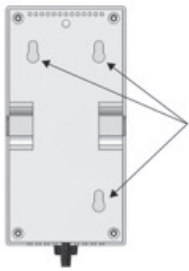

c)



### 3.1.5 Attachment of the extension module

Connect the diagnostic station and the extension module with the help of the connecting cable. In order to plug in the connecting cable (a). Close the casing opening of the extension module, which is not needed, with the sliding cover (b). Take the extension module and guide the screw heads through the openings (c). Then press the extension module downwards.

## 3.2 Icon Identification

<b>I</b>	ON
<b>0</b>	OFF
<b>HR</b>	Hour setting for the clock
<b>MIN</b>	Minute setting for the clock
	Dimming the instrument light on the handle
	Applied part Typ B
	Attention! Important note in this instruction use

## 3.3 Commissioning

- 3.3.1 Put the wall plug-in into the electrical socket. The optional clock starts to blink.  
You can adjust it to local time by repeatedly pressing the keys; with the left key marked HR and the right key marked MIN.
- 3.3.2 Move the handle upwards out of the handle holder and attach the desired instrument head by placing it with the two projecting guide cams onto the handle. Press the instrument head lightly onto the handle and turn the handle in a clockwise direction until it stops. Removal of the instrument head is carried out by turning in a counter-clockwise direction.
- 3.3.3 Switching on and off.  
Switch on the instrument by using the switching ring. Each handle is automatically ready to operate at 100% light intensity as soon as it is taken out of the handle holders.  
The handle is switched off automatically by putting back into the handle holder.  
The handle is automatically switched off when replaced back into the handle holder.
- 3.3.4 rheotronic® for light intensity modulation the modulation of light intensity can be done with the handle; you only have to tip the switching ring clockwise direction or against clockwise direction and the light gets stronger or weaker.

	<b>Attention!</b> The handle gets off automatically after abt. 3 minutes. Make sure that no more than 2 handles are used at the same time! If more than 2 handles are used at the same time, the transformer in the instrument may become overloaded and switch itself off.
--	--

## 3.4 ri-former® Diagnostic Station Mobile

Please follow the assembly instructions for the mobile stand with ri-former®. The assembly instructions is included in the mobile stand delivery package.

## 3.5 ri-former® Diagnostic Station Anesthesia

Assembly of the universal clamp.  
Please check if the designated wall rail is rigidly mounted on the wall. Fix the universal clamp on the determined place of the wall rail and tighten very well the locking screw. Put the preassembled ri-former® anesthesia device on the universal clamp and insert it. Please ensure that both pins are introduced in the universal clamp. Afterwards tighten the ri-former® anesthesia device with the lateral screw.



### Attention!

Take care that the connecting cable does not get caught behind the extension module. Push the connecting cable into the groove provided on the reverse side of the extension module.

## 4. Cleaning and Disinfection

### 4.1 General Information

Cleaning and disinfection of medical products protects patients, users and third parties, lead to value retention of medical products. Due to product design and materials used there is no possibility to define the maximum limit of re-processing cycles. The lifetime of a medical product is determined by its function and how it is used. Before sending back defective products for repair, the following instructions should be followed.

### 4.2 Cleaning and Disinfection

	<p><b>Attention!</b></p> <ul style="list-style-type: none"> <li>- We recommend to remove the wall plug- in of the ri-former® Diagnostic Station.</li> <li>- Take care when cleaning and disinfecting the ri-former® Diagnostic Station. The ri-former® Diagnostic Station can be cleaned on the outside (with the exception of the display glass cover) using a damp cloth until optical cleanliness is achieved. Use disinfection products only according to the manufacturer's instructions. Only disinfectants with proven effectiveness according to national guidelines should be used. After disinfection, please wipe the instruments using a damp cloth in order to eliminate any remnants of the disinfectant.</li> <li>- Never place the ri-former® Diagnostic Station and Extension Module or removable parts of the ri-former® Diagnostic Station (handle, cables, Instrument heads) in liquids!</li> <li>- The ri-former® Diagnostic Station is shipped non-sterile. DO NOT use ethylene oxide gas, heat, autoclave or any other harsh methods to sterilize the unit.</li> <li>- The devices are not meant to undergo machine-processed maintenance and sterilization. This could lead to irreversible damage!</li> <li>- The single use ear specula is only single use suitable!</li> </ul>
	For all reusable devices, if there are any signs of material degradation, the device should no longer be reused and should be disposed/claimed following the procedure mentioned under Disposal / Warranty.

## 5. Technical Data

Technical Data	
Medical device:	Medical device for powering instruments
Electrical protection:	Class II isolation equipment
Model	ri-former® Diagnostic Station with ri-former® Extension Module
Power supply	Input: 100 V-240 V AC / 50-60 Hz / 0,6 A Output: 5 V DC / 3 A / 15 W
ri-former® Diagnostic Station	Input: 5 V DC / 3 A / 15 W Output 1: 1 x 3.5 V dc / 700 mA Output 2: 2 x 5 V dc / 2 x 1,15 A
ri-former® Extension Module	Input: 5 V DC / 3 A / 15 W Output 1: 1 x 3,5 V dc / 700 mA Output 2: 1 x 5 V dc / 1 x 1,15 A
Classification	Application part type B
Operating conditions	0° C to + 40° C, 10% up to 85 % relative humidity
Storage and transport conditions	-5° C to + 50° C, 10% up to 85 % relative humidity
Airpressure	700 bis 1050 hPa
Dimensions	ri-former® Diagnostic station: 200 x 180.5 x 75 mm
Weight	ri-former® Diagnostic station: 800 g
Dimensions	ri-former® Extension Module: 200 x 100 x 75 mm
Weight	ri-former® Extension Module: 500 g
Switn-on time	ON: 1 Min / OFF: 5 Min

## 6. ri-scope®L Instrument heads

### ri-scope Instrument heads

ri-scope®L otoscope	ri-scope®L ophthalmoscopes	Slit and spot retinoscopes
Dermatoscope	Bent-arm illuminator	Nasal speculum
Tongue blade holder	Laryngeal mirror	Operation otoscope for human medicine
Operation otoscope for veterinary medicine		

### Putting the instruments heads into operation

Place the desired instrument head onto the attachment on the handle so that the two recesses on the lower part of the instrument head sit on top of the two projecting guide cams of the battery handle. Press the instrument head lightly onto the handle and turn the handle in a clockwise direction until it stops. To remove the head turn it in a counter-clockwise direction.

	<p><b>Function</b></p> <p>Place the desired instrument head onto the attachment on the handle so that the two recesses on the lower part of the instrument head sit on top of the two projecting guide cams of the battery handle. Press the instrument head lightly onto the handle and turn the handle in a clockwise direction until it stops.</p> <p>In order to activate the anti-theft security, turn the Allen screw (b) using the Allen key (a) (included with the instrument head) until it stops. The instrument head can now no longer be removed from the handle. In order to deactivate the anti-theft security, the Allen screw (b) has to be unscrewed again using the Allen key (a).</p>
--	--

### 6.1 ri-scope®L otoscope

#### 6.1.1 Intended use

The Riester otoscope described in these Operating Instructions is produced for illumination and examination of the auditory canal in combination with Riester ear specula.

#### 6.1.2 Fitting and removing ear specula

Either Riester disposable ear specula (blue colour) or reusable Riester ear specula (black colour) can be fitted to the otoscope head. The size of the ear specula is marked at the back of the specula.

L1 and L2 otoscopes:

Screw the specula clockwise until noticeable resistance is felt. To remove the specula, screw the specula counter clockwise.

L3 otoscope:

Fit the chosen specula on the chrome-plated metal fixture of the otoscope until it locks into place. To remove the specula, press the blue ejection button. The specula is automatically ejected.

### 6.1.3 Swivel lens for magnification

The swivel lens is fixed to the device and can be swivelled 360°.

### 6.1.4 Insertion of external instruments into the ear

If you wish to insert external instruments into the ear (e.g. tweezers), you have to rotate the swivel lens (approx. 3-fold magnification) located on the otoscope head by 180°. Now you can use the operation lens.

### 6.1.5 Pneumatic test

To perform the pneumatic test (= examination of the eardrum), you require a ball, which is not included in the normal delivery package, but can be ordered separately. The tube for the ball is attached to the connector. Now you can carefully insert the necessary volume of air into the ear canal.

### 6.1.6 Technical data of the lamp

Otoscope XL 2.5 V 2.5 V 750 mA ave. life 15 h

Otoscope XL 3.5 V 3.5 V 720 mA ave. life 15 h

Otoscope LED 2.5 V 2.5 V 280 mA ave. life 10.000 h

Otoscope LED 3.5 V 3.5 V 280 mA ave. life 10.000 h

## 6.2 ri-scope®L ophthalmoscopes

### 6.2.1 Intended use

The Riester ophthalmoscope described in these Operating Instructions is produced for the examination of the eye and the eyeground.



#### Attention!

Because prolonged intense exposure to light can damage the retina, the use of the eye exam device should not be unnecessarily prolonged, and the brightness setting should not be set higher than needed for a clear representation of the target structures.

The irradiation dose of the photochemical exposure to the retina is the product of irradiance and duration of irradiation. If the irradiance is reduced by half, the irradiation time may be twice as long to reach the maximum limit.

Although no acute optical radiation hazards have been identified for direct or indirect ophthalmoscopes, it is recommended that the intensity of light directed into the patient's eye be reduced to the minimum required for examination / diagnosis. Infants / children, aphasics and people with eye diseases are at a higher risk. The risk may be increased if the patient has already been examined with this or another ophthalmological instrument during the last 24 hours. This is especially true when the eye has been exposed to retinal photography.

The light of this instrument may be harmful. The risk of eye damage increases with the duration of irradiation. An irradiation period with this instrument at maximum intensity of longer than >5 min. exceeds the guideline value for hazards. This instrument does not pose a photobiological hazard according to DIN EN 62471 but still features a safety shutdown after 2 / 3 minutes.

### 6.2.2 Lens wheel with correction lens

The correction lens can be adjusted on the lens wheel. The following correction lenses are available:

L1 and L2 ophthalmoscopes:

Plus: 1-10, 12, 15, 20, 40.

Minus: 1-10, 15, 20, 25, 30, 35.

L3 ophthalmoscope:

Plus: 1-45 in single steps

Minus: 1-44 in single steps

The values can be read off in the illuminated field of view. Plus values are displayed in green numbers, minus values with red numbers.

### 6.2.3 Apertures

The following apertures can be selected with the aperture hand-wheel:

L1 ophthalmoscope:







Semi-circle, small/medium/large circular aperture, fixation star, slit.

L2 ophthalmoscope:

Semi-circle, small/medium/large circular aperture, fixation star and slit.

L3 ophthalmoscope:

Semi-circle, small/medium/large circular aperture, fixation star, slit and grid.

Aperture	Function
	Semicircle: for examinations with turbid lenses
	Small circle: to reduce reflections for small pupils
	Medium circle: to reduce reflections for small pupils
	Large circle: for normal examination results
	Grid: for topographic determination of retina changes
	Light slit: to determine differences in level
	Fixation star: to ascertain central of eccentric fixation

### 6.2.4 Filters

Using the filter wheel, the following filters can be switched for each aperture:

L1 ophthalmoscope Red-free filter

L2 ophthalmoscope Red-free filter, blue filter and polarisation filter.

L3 ophthalmoscope Red-free filter, blue filter and polarisation filter.

Filter	Function
Red-free filter:	contrast enhancing to assess fine vascular changes, e.g. retinal bleeding
Polarisation filter:	for precise assessment of tissue colours and to avoid retinal reflections
Blue filter:	for improved recognition of vascular abnormalities or bleeding, for fluorescence ophthalmology

For L2 + L3, every filter can be switched to every aperture.

### 6.2.5 Focussing device (only with L3)

Fast fine adjustment of the examination area to be observed is achieved from various distances by turning the focussing wheel.

### 6.2.6 Magnifying glass

A magnifying glass with 5-fold magnification is supplied with the ophthalmoscope set. This can be positioned between the instrument head and the area under examination, as required. The area under examination is magnified accordingly.

### 6.2.7 Technical data on the lamp

XL 2.5 V ophthalmoscope: 750 mA ave. life 15 h

XL 3.5 V ophthalmoscope: 690 mA ave. life 15 h

LED 3.5 V ophthalmoscope: 280 mA ave. life 10.000 h

## 6.3 Slit and spot retinoscopes

### 6.3.1 Intended use

The slit/spot retinoscopes (also known as skiascopes) described in these Operating Instructions are produced to determine the refraction (ametropias) of the eye.

### 6.3.2 Commissioning and function

Position the required instrument head on point of attachment on top section of handle with both recesses of the instrument head bottom section being congruent with the two projecting guide cams of the battery handle. Press instrument head lightly on battery handle and rotate handle in clockwise direction to the stop. Remove head by rotating in counter-clockwise direction. Rotation and focusing of the slit and/or spot image may now be effected by the knurled screw.

### 6.3.3 Rotation

The slit or spot image may be rotated by 360° by the control. Each angle may be directly read from the scale on the retinoscope.

### 6.3.4 Fixation cards

Fixation cards are suspended and fixed on the object side of the retinoscope into the bracket for the dynamic skiascope.

### 6.3.5 Slit/Spot design

The slit retinoscope may be converted to a spot retinoscope by exchanging the slit lamp against a spot lamp.

### 6.3.6 Technical data of the lamp

Slit retinoscope HL 2.5 V 2.5 V 440 mA mean life span 15 h  
Slit retinoscope XL 3.5 V 3.5 V 690 mA mean life span 50 h  
Spot retinoscope HL 2.5 V 2.5 V 450 mA mean life span 15 h  
Spot retinoscope XL 3.5 V 3.5 V 640 mA mean life span 40 h

## 6.4 ri-derma Dermatoscope

### 6.4.1 Intended use

The ri-derma dermatoscope described in these Operating Instructions is produced for early identification of changes of skin pigmentation (malignant melanomas).

### 6.4.2 Commissioning and function

Position the required instrument head on point of attachment on top section of handle with both recesses of the instrument head bottom section being congruent with the two projecting guide cams of the battery handle. Press instrument head lightly on battery handle and rotate handle in clockwise direction to the stop. Remove head by rotating in counter-clockwise direction.

### 6.4.3 Focusing

Focus the magnifying glass by rotating the eyepiece ring.

### 6.4.4 Skin-friendly contact plates

2 skin-friendly contact plates are included:

- **With a scale of 0-10 mm for the measurement of pigmented lesions such as malignant melanoma.**
- **Without scaling.**

Both contact plates are easily removable and replaceable.

### 6.4.5 Technical data of the lamp

ri-derma XL 2.5 V 2.5 V 750 mA ave. life 15 h  
ri-derma XL 3.5 V 3.5 V 690 mA ave. life 15 h  
ri-derma LED 2.5 V 2.5 V 280 mA ave. life 10.000 h  
ri-derma LED 3.5 V 3.5 V 280 mA ave. life 10.000 h24

## 6.5 Bent-arm illuminator

### 6.5.1 Intended use

The bent-arm illuminator described in these Operating Instructions is produced for illuminating the oral cavity and the pharynx.

### 6.5.2 Commissioning and function

Position the required instrument head on point of attachment on top section of handle with both recesses of the instrument head bottom section being congruent with the two projecting guide cams of the battery handle. Press instrument head lightly on battery handle and rotate handle in clockwise direction to the stop. Remove head by rotating in counter-clockwise direction.

### 6.5.3 Technische Daten der Lampe

Bent-arm illuminator XL 2.5 V 2.5 V 750 mA ave. life 15 h  
Bent-arm illuminator XL 3.5 V 3.5 V 690 mA ave. life 15 h  
Bent-arm illuminator LED 2.5 V 2.5 V 280 mA ave. life 10.000 h  
Bent-arm illuminator LED 3.5 V 3.5 V 280 mA ave. life 10.000 h

## 6.6 Nasal speculum

### 6.6.1 Intended use

The nasal speculum described in these Operating Instructions is produced for illumination and therefore examination of the inside of the nose.

### 6.6.2 Commissioning and function

Position the required instrument head on point of attachment on top section of handle with both recesses of the instrument head bottom section being congruent with the two projecting guide cams of the battery handle. Press instrument head lightly on battery handle and rotate handle in clockwise direction to the stop. Remove head by rotating in counter-clockwise direction.

For two modes of operation:

Fast expansion:

Push set screw on instrument head down with your thumb.

This setting does not allow changes in the position of the specula legs.

Individual expansion:

Rotate set screw in clockwise direction until the required expansion width is obtained. Close legs again by turning screw in clockwise direction.

### 6.6.3 Swivel lens

The nasal specula is equipped with a swivel lens of approx. 2.5X enlargement which may be simply pulled out and/or replaced in the opening provided on the nasal specula.

### 6.6.4 Technical data of the lamp

Nasal specula XL 2.5 V 2.5 V 750 mA ave. life 15 h  
Nasal specula XL 3.5 V 3.5 V 720 mA ave. life 15 h  
Nasal specula LED 2.5 V 2.5 V 280 mA ave. life 10.000 h  
Nasal specula LED 3.5 V 3.5 V 280 mA ave. life 10.000 h

## 6.7 Tongue blade holder

### 6.7.1 Intended use

The Tongue blade holder described in these Operating Instructions is produced for examination of the oral cavity and pharynx in combination with commercial wooden and plastic blades.

### 6.7.2 Commissioning and function

Position the required instrument head on point of attachment on top section of handle with both recesses of the instrument head bottom section being congruent with the two projecting guide cams of the battery handle. Press instrument head lightly on battery handle and rotate handle in clockwise direction to the stop. Remove head by rotating in counter-clockwise direction. Insert a commercial wooden or plastic tongue blade into the aperture below the light opening up to the stop. The tongue blade is easy to remove after examination by actuating the ejector.

### 6.7.3 Technical data of the lamp

Depressor holder XL 2.5 V 2.5 V 750 mA ave. life 15 h  
Depressor holder XL 3.5 V 3.5 V 720 mA ave. life 15 h  
Depressor holder LED 2.5 V 2.5 V 280 mA ave. life 10.000 h  
Depressor holder LED 3.5 V 3.5 V 280 mA ave. life 10.000 h

## 6.8 Laryngeal mirror

### 6.8.1 Intended use

The laryngeal mirrors described in these Operating Instructions are produced for mirroring or examination of the oral cavity and pharynx in combination with the Riester bent-arm illuminator.

### 6.8.2 Commissioning and function

Laryngeal mirrors may only be used in combination with the bent arm illuminator, thus ensuring maximum lighting conditions. Take two laryngeal mirrors and fix them in the required direction on the bent-arm illuminator.

## 6.9 Operation otoscope for veterinary medicine without speculum

### 6.9.1 Intended use

The Riester operation otoscope described in these Operating Instructions is produced exclusively for use on animals and for veterinary medicine and therefore bears no CE mark. It can be used for illumination and examination of the auditory canal, as well as for minor operations in the auditory canal.

### 6.9.2 Attachment and removal of ear specula in veterinary medicine

Position the required specula on the black bracket of the operating otoscope, with the recess of the specula fitting into the guide of the bracket. Attach specula by rotating in anti-clockwise direction.

### 6.9.3 Swivel lens for enlargement

The operating otoscope comprises a small magnifying lens to be swivelled at an angle of 360° for a maximum enlargement of approx. 2.5 x.

### 6.9.4 Insertion of external instruments into the ear

The operation otoscope is designed to be open so that external instruments can be inserted into the animal ear.

### 6.9.5 Technical data of the lamp

Operating otoscope HL 2.5 V 2.5 V 680 mA ave. life 20 h  
Operating otoscope XL 3.5 V 3.5 V 700 mA ave. life 20 h



## 6.10 Operation otoscope for human medicine

### 6.10.1 Intended use

The Riester operation otoscope described in these Operating Instructions is produced for illumination and examination of the auditory canal and for insertion of external instruments into the auditory canal.

### 6.10.2 Placing and removing ear specula for human medicine

Place the desired specula on the black holder on the surgical scope so that the notch on the specula fits into the guide in the holder. Fasten the specula by turning it clockwise.

### 6.10.3 Swivel magnifying lens for enlarging

There is a small 360° swivel magnifying lens on the surgical ophthalmoscope with a magnification power of about 2.5 times.

### 6.10.4 Insertion of external instruments into the ear

The operating otoscope is designed so that external instruments can be inserted into the ear.

### 6.10.5 Technical data of the lamp

Operating otoscope HL 2.5 V 2.5 V 680 mA ave. life 40 h  
Operating otoscope XL 3.5 V 3.5 V 700 mA ave. life 40 h

## 7. Replacing the lamp

### Otoscope L1

Remove the specula receptacle from the otoscope. Unscrew the lamp counter clockwise. Tighten the new lamp clockwise and reattach the specula receptacle.

### 7.1 Oscopes L2, L3, ri-derma, lamp holder, nasal specula and tongue blade holder

Remove the instrument head from the battery handle. The lamp is located at the bottom of the instrument head. Pull the lamp out of the instrument head using your thumb and forefinger or a suitable tool. Insert the new lamp firmly.

### 7.2 Ophthalmoscopes

Remove the instrument head from the battery handle. The lamp is located at the bottom of the instrument head. Remove the lamp from the instrument head using your thumb and forefinger or a suitable tool. Insert the new lamp firmly.

### 7.3 Retinoscope slit and spot

Remove the instrument head from the battery handle. The lamp is located in a sleeve at the base of the instrument head. Remove the lamp from the sleeve using the thumb and index finger or a suitable tool. Insert the new lamp firmly into the sleeve and replace the sleeve back into the instrument head so that the base of the lamp fits into the slot on the instrument head.



#### Attention!

The pin of the lamp must be inserted into the guide groove on the ophthalmoscope's instrument head.

## 8. Care instructions

### 8.1 General note

The cleaning and disinfecting of the medical devices serve to protect the patient, the user and third parties and to maintain the value of the medical devices.

Due to the product design and the materials used, there is no defined upper limit on feasible reprocessing cycles. The service life of medical devices is determined by their function and careful handling.

Defective products must have completed the entire reprocessing procedure before being returned for repair.

### 8.2 Cleaning and disinfecting

The instrument heads and handles can be cleaned externally with a damp cloth until visual cleanliness is achieved.

Wipe with disinfectant according to the instructions of the disinfectant manufacturer. Only cleaning agents with proven efficacy should be used under consideration of national requirements.

After disinfecting, wipe the instrument with a damp cloth to remove possible disinfectant residue.

The contact plates (ri-derma) can be rubbed off with alcohol or a suitable disinfectant



#### Attention!

Never place the spiral cable / handle / instrument heads in liquids! Make sure that no liquids penetrate the housing interior!  
The article is not approved for machine reprocessing and sterilisation. This can lead to irreparable damage!

## 8.3 Sterilisation

Reusable ear specula:

The ear specula can be sterilised at 134° C, with a 10 minute period in the steam steriliser.

Single use ear specula:

For single use only!



#### Warning!

- Disposable ear specula  
Only use new ear specula to limit the risk of cross contamination.  
- Reusable ear specula  
Only use cleaned / sterilized ear specula to limit the risk of cross contamination



#### Attention!

More information about  
ri-scope®L  
ri-scope  
are in the Instruction of use Art.No.99220

## 9. Spare parts and accessories

A detailed list can be found in „Instruments for H.N.O.,“ Ophthalmologic Instruments, which you can find at [www.riester.de](http://www.riester.de)  
<https://www.riester.de/en/productdetails/d/ri-scope-l-premium-ent-and-ophthalmic-instruments/other-ri-scope-l-accessories/>

## 10. Electromagnetic Compatibility accompanying Documents according to IEC 60601-1-2

The instrument satisfies the requirements for electromagnetic compatibility. Please note that under the influence of unfavorable field strengths, e.g. during the operation of wireless telephones or radiological instruments, adverse effects on function cannot be excluded.

The electromagnetic compatibility of this device has been verified by test according to the IEC60601-1-2 requirements.

### 10.1 EMC (electromagnetic compatibility)

#### 10.1.1

During installation and operation of the device, observe the following instructions:

#### 10.1.2

Do not use the device simultaneously with other electronic equipment to avoid electromagnetic interference with the operation of the device.

10.1.3 Do not use or stack the device near, on, or under other electronic equipment to avoid electromagnetic interference with the operation of the device.

#### 10.1.4

Do not use the device in the same room as other electronic equipment, such as life-support equipment that has major effects on the life of the patient and results of treatment, or any other measurement or treatment equipment that involves small electric current.

#### 10.1.5

Do not use cables or accessories that are not specified for the device because that may increase the emission of electromagnetic waves from the device and decrease the immunity of the device to electromagnetic disturbance.

	<p><b>Attention!</b> Medical electrical equipment is subject to special precautions regarding electromagnetic compatibility (EMC). Portable and mobile radio frequency communication devices can affect medical electrical equipment. The ME device is for operation in an electromagnetic environment and intended for professional facilities such as industrial areas and hospitals. The user of the device should ensure that it is operated within such an environment.</p>
---	--

	<p><b>Warning!</b> The ME device may not be stacked, arranged or used directly next to or with other devices. When operation is required to be close to or stacked with other devices, the ME device and the other ME devices must be observed in order to ensure proper operation within this arrangement. This ME device is intended for use by medical professionals only. This ME device is intended for use in Professional Healthcare Facility Environment. This device may cause radio interference or interfere with the operation of nearby devices. It may become necessary to take appropriate corrective measures, such as redirecting or rearranging the ME device or shield. The rated ME device does not exhibit any basic performance features in the sense of IEC 60601-1, which would present an unacceptable risk to patients, operators or third parties should the power supply fail or malfunction.</p>
---	---

	<p><b>Warning!</b> Portable RF communications equipment (radios) including accessories, such as antenna cables and external antennas, should not be used in closer proximity than 30 cm (12 inches) to parts and cables of the Diagnostic station ri-former specified by the manufacturer. Failure to comply may result in a reduction in the device's performance features. Directives and manufacturer's declaration - Electromagnetic emissions The Diagnostic station ri-former are intended for use in the electromagnetic environment specified below. The customer or user of the Diagnostic station ri-former should ensure that it is used in such an environment.</p>
---	---

<b>Guidance and manufacture's declaration – electromagnetic immunity</b>			
The <b>ri-former</b> ® Diagnostic Station is intended for use in the electromagnetic environment specified below. The customer or the user of <b>ri-former</b> ® Diagnostic Station should assure that it is used in such an environment.			
<b>Immunity test</b>	<b>IEC 60601 test level</b>	<b>Compliance level</b>	<b>Electromagnetic environment - guidance</b>
Electrostatic discharge (ESD) IEC 61000-4-2	Con: ± 8 kV Air: ± 15 kV	Con: ± 8 kV Air: ± 15 kV	Floors should be wood, concrete or ceramic tile. If floor are covered with synthetic material, the relative humidity should be at least 30%. The quality of the supply voltage should be that of a typical business or hospital environment.
Electrical fast transient/burst IEC 61000-4-4	5/50 ns, 100 kHz; ±2 kV	5/50 ns, 100 kHz; ±2 kV	
Surge IEC 61000-4-5	1.2/50 (8/20) µs LtL: ± 1.0 kV LtG: ± 2.0 kV	1.2/50 (8/20) µs LtL: ± 1.0 kV LtG: ± 2.0 kV	The quality of the supply voltage should be that of a typical business or hospital environment.
Voltage dips, short interruptions and voltage variations on power supply input lines IEC 61000-4-11	0 % UT for 0.5 cycle (1 phase) 0 % UT for 1 cycle 70 % UT for 25/30 cycles (50/60 Hz)	0 % UT for 0.5 cycle (1 phase) 0 % UT for 1 cycle 70 % UT for 25/30 cycles (50/60 Hz)	The quality of the supply voltage should be that of a typical business or hospital environment.
	0 % UT for 250/300 cycles (50/60 Hz)	0 % UT for 250/300 cycles (50/60 Hz)	
Power frequency (50Hz/60Hz) magnetic field IEC 61000-4-8	30 A/m 50 Hz	30 A/m 50 Hz	Mains frequency magnetic fields should be at a level characteristic of a typical location in a typical commercial hospital environment.
NOTE: U <sub>T</sub> is the a.c. mains voltage prior to application of the test level.			

<b>Guidance and manufacture's declaration – electromagnetic emission</b>		
The <b>ri-former</b> ® Diagnostic Station intended for use in the electromagnetic environment specified below. The customer of the user of the Diagnostic station ri-former should assure that it is used in such an environment.		
<b>Emission test</b>	<b>Compliance</b>	<b>Electromagnetic environment - guidance</b>
RF-Emissionen CISPR 11	Group 1	The <b>ri-former</b> ® Diagnostic Station uses RF energy only for its internal function. Therefore, its RF emissions are very low and are not likely to cause any interference in nearby electronic equipment.  The <b>ri-former</b> ® Diagnostic Station is intended for use in all establishments, including residential areas and those directly connected to a public supply network that also supplies buildings used for residential purposes.
RF-Emission CISPR 11	Class B	
Harmonic emissions IEC 61000-3-2	Pass	
Voltage fluctuations/ flicker emissions IEC 61000-3-3	Pass	

Guidance and manufacture's declaration – electromagnetic immunity			
The <b>ri-former®</b> Diagnostic Station is intended for use in the electromagnetic environment specified below. The customer or the user of the Diagnostic station <b>ri-former</b> should assure that it is used in such an environment.			
Immunity test	IEC 60601 test level	Compliance level	Electromagnetic environment - guidance
Conducted RF IEC 61000-4-6	Pass	Pass	Portable and mobile RF communications equipment should not be used closer to any part of the <b>ri-former®</b> Diagnostic Station, including the cables, than the recommended distance, which is calculated using the equation applicable to the transmitter frequency. <b>Recommended separation distance</b> d= 1.2√P 150 KHz to 80 MHz d= 1.2√P 80 MHz to 800 MHz d= 2.3√P 800 MHz to 2,7 GHz
Radiated RF IEC 61000-4-3	3 V/m 80 MHz to 2,7 GHz	3 V/m	
Proximity fields from RF wireless communications equipment	Pass	Pass	Where P is the maximum output power rating of the transmitter in watts (W) according to the transmitter manufacturer and d is the recommended separation distance in metres (m). Field strengths from fixed RF transmitters, as determined by an electromagnetic site survey, should be less than the compliance level in each frequency range. b Interference may occur in the vicinity of equipment marked with the following symbol:  Where P is the maximum output power of the transmitter in watts (W) according to the transmitter manufacturer and the recommended distance is given in meters (m). Field strengths from fixed RF transmitters determined by an electromagnetic site survey a, should be less than the compliance level in each frequency range b. Interference may occur in the vicinity of devices marked with the following symbol:  
NOTE 1 At 80 MHz and 800 MHz, the higher frequency range applies. NOTE 2 These guidelines may not apply in all situations. Electromagnetic propagation is affected by absorption and reflection from structures, objects and people.			
a.) Field strengths from fixed transmitters, such as base stations for radio (cellular/cordless) telephones and landmobile radios, amateur radio, AM and FM radio broadcast and TV broadcast cannot be predicted theoretically with accuracy. To assess the electromagnetic environment due to fixed RF transmitters, an electromagnetic site survey should be considered. If the measured field strength in the location in which the Diagnostic station <b>ri-former</b> is used exceeds the applicable RF compliance level above, the Diagnostic station <b>ri-former</b> should be observed to verify normal operation. If abnormal performance is observed, additional measures may be necessary, such as re-orienting or relocating the <b>ri-former®</b> Diagnostic Station. b.) Over the frequency range 150 kHz to 80 MHz, field strengths should be less than 3 V/m.			



Recommended separation distances between portable and mobile RF communications equipment and the <b>ri-former®</b> Diagnostic Station.			
The <b>ri-former®</b> Diagnostic Station is intended for use in an electromagnetic environment in which radiated RF disturbances are controlled. The customer or the user of the <b>ri-former®</b> Diagnostic Station can help prevent electromagnetic interference by maintaining a minimum distance between portable and mobile RF communications equipment (transmitters) and the <b>ri-former®</b> Diagnostic Station as recommended below, according to the maximum output power of the communications equipment.			
Rated maximum output power of transmitter (W)	Separation distance according to frequency of transmitter (m)		
	150 kHz to 80 MHz	80 MHz to 800 MHz	800 MHz to 2,7 GHz
	$d = 1,2\sqrt{P}$	$d = 1,2\sqrt{P}$	$d = 2,3\sqrt{P}$
0,01	<b>0,12</b>	<b>0,12</b>	<b>0,23</b>
0,1	<b>0,38</b>	<b>0,38</b>	<b>0,73</b>
1	<b>1,2</b>	<b>1,2</b>	<b>2,3</b>
10	<b>3,8</b>	<b>3,8</b>	<b>7,3</b>
100	<b>12</b>	<b>12</b>	<b>23</b>
For transmitters rated at a maximum output power not listed above, the recommended separation distance d in metres (m) can be estimated using the equation applicable to the frequency of the transmitter, where P is the maximum output power rating of the transmitter in watts (W) according to the transmitter manufacturer. NOTE 1: At 80 MHz and 800 MHz, the separation distance for the higher frequency range applies. NOTE 2: These guidelines may not apply in all situations. Electromagnetic propagation is affected by absorption and reflection from structures, objects and people.			

## 11. Accessories

Art. No.: 3652-600	<b>ri-former®</b> with foot and big ben® 3.5 V / 100-240 V
Art. No.: 3652-500	<b>ri-former®</b> with foot 3,5 V / 100-240 V
Art. No.: 3652-400	<b>ri-former®</b> anesthesia model without universal clamp 3.5 V / 100-240 V
Art. No.: 10384	Universal clamp Extension module, big-ben
Art. No.: 3655-103	big ben® Wickelman. adult
Art. No.: 3655-106	Hakenman. adult
Art. No.: 3655-109	Klettenman. adult
Art. No.: 3655-123	Klettenman. strong arms
Art. No.: 3655-130	Klettenman. children Extension module, infrared thermometer <b>ri-thermo®</b> N
Art. No.: 3656	Extension module, infrared thermometer <b>ri-thermo®</b> N without anti-theft device
Art. No.: 3656-301	Extension module, infrared thermometer <b>ri-thermo®</b> N with anti-theft device
Art. No.: 3654	<b>ri-spec</b> Ear specula Dispenser Packed in a polybag 25 pcs.
Art. No.: 14065-531	1 box 40 poly bags 1000 pcs. 2.5 mm hopper Packed in a polybag 25 pcs.
Art. No.: 14065-534	1 box 40 poly bags 1000 pcs. 4 mm funnels Packed in a polybag 25 pcs. <b>ri-former®</b> Instrument heads without anti-theft device with anti-theft device <b>ri-scope®</b> L F.O. Oscope
Art. No.: 10563 Art. No.: 10563-301	L1 3,5 V XL L1 3,5 V XL with anti-theft device
Art. No.: 10580 Art. No.: 10580-301	L2 3,5 V XL L2 3,5 V XL with anti-theft device
Art. No.: 10565 Art. No.: 10565-301	L2 3,5 V LED L2 3,5 V LED with anti-theft device

Art. No.: 10581 Art. No.: 10581-301	L3 3,5 V XL L3 3,5 V XL with anti-theft device
Art. No.: 10567 Art. No.: 10567-301	L3 3,5 V LED L3 3,5 V LED with anti-theft device
	ri-scope® Human surgical otoscope without ear specula
Art. No.: 10561 Art. No.: 10561-301	3,5 V XL 3,5 V XL with anti-theft device
	ri-scope® Veterinary surgical otoscope without ear specula
Art. No.: 10542	3,5 V XL
Art. No.: 10542-301	3,5 V XL with anti-theft device
	ri-scope® L Ophthalmoscope
Art. No.: 10569 Art. No.: 10569-301	L1 3,5 V XL L1 3,5 V XL with anti-theft device
Art. No.: 10571 Art. No.: 10571-301	L2 3,5 V XL L2 3,5 V XL with anti-theft device
Art. No.: 10571-203 Art. No.: 10595-301	L2 3,5 V LED L2 3,5 V LED with anti-theft device
Art. No.: 10573 Art. No.: 10573-301	L3 3,5 V XL L3 3,5 V XL with anti-theft device
Art. No.: 10573-203 Art. No.: 10596-301	L3 3,5 V LED L3 3,5 V LED with anti-theft device
	ri-scope® L Retinoscope (Skiascope)
Art. No.: 10544 Art. No.: 10544-301	with Spaltlampe 3,5 V XL with Spaltlampe 3,5 V XL with anti-theft device
Art. No.: 10546 Art. No.: 10546-301	with Punktlampe 3,5 V XL with Punktlampe 3,5 V XL with anti-theft device
	ri-derma® Dermatoscope
Art. No.: 10551 Art. No.: 10551-301	3,5 V XL 3,5 V XL with anti-theft device
Art. No.: 10577 Art. No.: 10577-301	3,5 V LED 3,5 V LED with anti-theft device
	ri-scope® L F.O. tongue depressor holder
Art. No.: 10535 Art. No.: 10535-301	3,5 V XL 3,5 V XL with anti-theft device
Art. No.: 10574 Art. No.: 10574-301	3,5 V LED 3,5 V LED with anti-theft device
	ri-scope® L F.O. Nasal specula
Art. No.: 10537 Art. No.: 10537-301	3,5 V XL 3,5 V XL with anti-theft device
Art. No.: 10575 Art. No.: 10575-301	3,5 V LED 3,5 V LED with anti-theft device
	ri-scope® L F.O. Lamp holder
Art. No.: 10539 Art. No.: 10539-301	3,5 V XL 3,5 V XL with anti-theft device
Art. No.: 10576 Art. No.: 10576-301	3,5 V LED 3,5 V LED with anti-theft device
	EliteVue
Art. No.: 10512	EliteVue head, single, LED, 3,5 V
Art. No.: 10512-301	EliteVue head, single, LED, 3,5 V, with anti-theft device (for ri-former wall station)]
Art. No.: 10513	EliteVue head, single, XL, 3,5 V
Art. No.: 10513-301	EliteVue head, single, XL, 3,5 V, with anti-theft device (for ri-former wall station)]

## 12. Disposal

	<b>Attention!</b> Disposal of the used medical device must be performed in accordance with current medical practices or local regulations regarding disposal of infectious, biological medical waste.
	Batteries and electrical/electronic devices must be disposed in accordance with locally applicable regulations, not with domestic waste.
	If you have any questions regarding disposal of products, please contact the manufacturer or its representatives.

## 13. Warranty:

This product has been manufactured under the strictest quality standards and has undergone a thorough final quality check before leaving our factory. We are therefore pleased to be able to provide a warranty of 2 years from the date of purchase on all defects, which can verifiably be shown to be due to material or manufacturing faults. A warranty claim does not apply in the case of improper handling. All defective parts of the product will be replaced or repaired free of charge within the warranty period. This does not apply to wearing parts. For R1 shock-proof, we grant an additional warranty of 5 years for the calibration, which is required by CE-certification. A warranty claim can only be granted if this warranty card has been completed and stamped by the dealer and is enclosed with the product. Please remember that all warranty claims have to be made during the warranty period. We will, of course, be pleased to carry out checks or repairs after expiry of the warranty period at a charge. You are also welcome to request a provisional cost estimate from us free of charge. In case of a warranty claim or repair, please return the Riester product with the completed warranty Card to the following address:

Rudolf Riester GmbH  
Dept. Repairs RR  
Bruckstr. 31  
72417 Jungingen  
Deutschland

Serial number or batch number  
Date, Stamp and signature of the specialist dealer

