



microlife®

AFIB ADVANCED Easy

EN
IT
FR
DE



BP A6 Advanced Easy

microlife®

Numero Verde
800-510661
SERVIZIO CONSUMATORI

Microlife AG
Epenstrasse 139
9443 Widnau / Switzerland
www.microlife.com

CE0044

Distributore per l'Italia

COLPHARMA

Colpharma s.r.l.
Parma - Italy
www.colpharma.com

IB BP A6 Advanced Easy IT-V4 2917

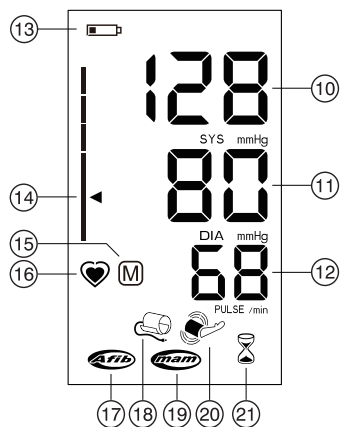
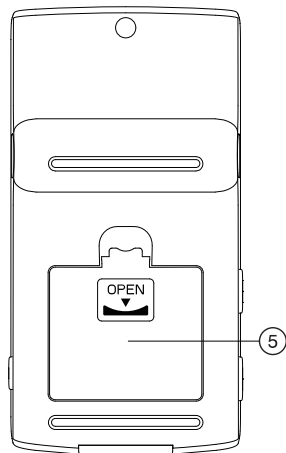
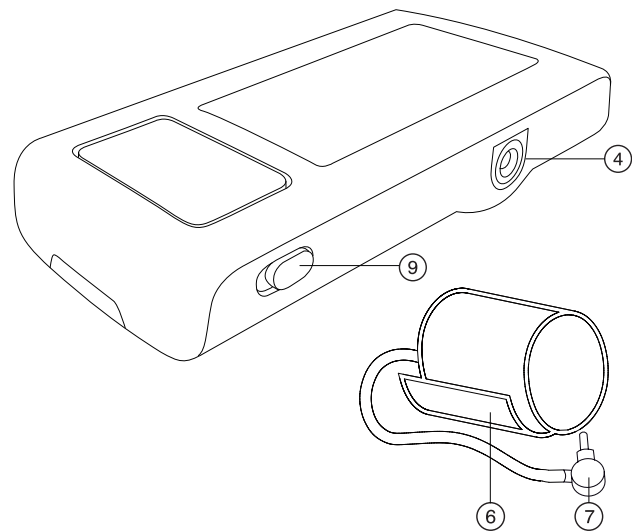
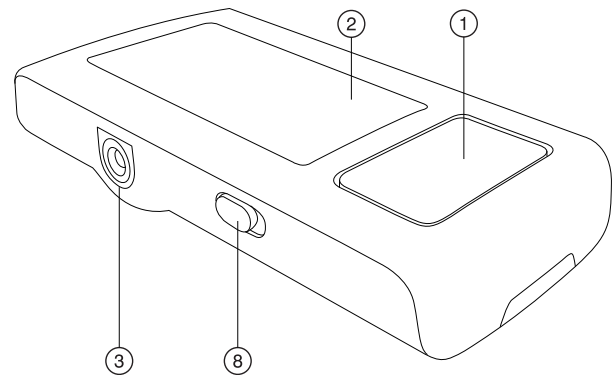

Name of Purchaser / Nome del rivenditore /
Nom de l'acheteur / Name des Käufers

Serial Number / Numero di serie /
Numéro de série / Serien-Nr.

Date of Purchase / Data d'acquisto /
Date d'achat / Kaufdatum

Specialist Dealer / Categoria rivenditore /
Revendeur / Fachhändler

- ① START/STOP Button
- ② Display
- ③ Cuff Socket
- ④ Mains Adapter Socket
- ⑤ Battery Compartment
- ⑥ Cuff
- ⑦ Cuff Connector
- ⑧ MAM Switch
- ⑨ Lock Switch

Display

- ⑩ Systolic Value
- ⑪ Diastolic Value
- ⑫ Pulse Rate
- ⑬ Battery Display
- ⑭ Traffic Light Indicator
- ⑮ Stored Value
- ⑯ Pulse Indicator
- ⑰ Atrial Fibrillation Indicator (AFIB)
- ⑱ Cuff Check Indicator
- ⑲ MAM Mode
- ⑳ Arm Movement Indicator
- ㉑ MAM Interval Time



Read the instructions carefully before using this device.



Type BF applied part



Keep dry

Dear Customer,

Your new Microlife blood pressure monitor is a reliable medical device for taking measurements on the upper arm. It is simple to use, accurate and comes highly recommended for blood pressure monitoring in your home. This device was developed in collaboration with physicians and clinical tests carried out prove its measurement accuracy to be of a very high standard.*

Microlife AFIB detection is the world's leading digital blood pressure measurement technology for the detection of atrial fibrillation (AF) and hypertension. These are the two top risk factors of getting a stroke or heart disease in the future. It is important to detect AF and hypertension at an early stage, even though you may not experience any symptoms. Appropriate treatment will reduce your risk of suffering a stroke. For this reason, it is recommended that you visit your doctor when the device gives an AFIB signal during your blood pressure measurement. The AFIB algorithm of Microlife has been clinically investigated by several prominent clinical investigators and showed that the device detects patients with AFIB at a certainty of 97-100%.^{1,2,3}

Please read through these instructions carefully so that you understand all functions and safety information. We want you to be happy with your Microlife product. If you have any questions, problems or want to order spare parts please contact your local Microlife-Customer Service. Your dealer or pharmacy will be able to give you the address of the Microlife dealer in your country. Alternatively, visit the internet at www.microlife.com where you will find a wealth of invaluable information on our products.

Stay healthy – Microlife AG!

* This device uses the same measuring technology as the award winning «BP 3BTO-A» model tested according to the British Hypertension Society (BHS) protocol.

¹ Stergiou GS, Karpettas N, Protogerou A, Nasothimiou EG, & Kyriakidis M. Diagnostic accuracy of a home blood pressure monitor to detect atrial fibrillation. *J Hum Hyperten* 2009; 1-5.

² Wiesel J, Fitzig L, Herschman Y, & Messineo FC Detection of Atrial Fibrillation Using a Modified Microlife Blood Pressure Monitor. *Am J Hypertens* 2009; 848-852.

³ Kearley K, Selwood M, Van den Bruel A, Thompson M, Mant D, Hobbs FR, Fitzmaurice D, Heneghan C: Triage tests for identifying atrial fibrillation in primary care: a diagnostic accuracy study comparing single-lead ECG and modified BP monitors. *BMJ Open* 2014; 4:

Table of Contents

1. **Important Facts about Blood Pressure and Self-Measurement**
 - How do I evaluate my blood pressure?
2. **Important Facts about Atrial Fibrillation (AF)**
 - What is Atrial Fibrillation (AF)?
 - How does AF impact my family or me?
 - Microlife AFIB detection provides a convenient way to screen for AF
 - Risk factors you can control
3. **Using the Device for the First Time**
 - Inserting the batteries
 - Selecting the correct cuff
 - Select the measuring mode: standard or MAM mode
 - MAM mode
4. **Taking a Blood Pressure Measurement using this Device**
5. **Appearance of the Atrial Fibrillation Indicator for early Detection**
6. **Traffic Light Indicator in the Display**
7. **Data Memory**
8. **Battery Indicator and Battery change**
 - Low battery
 - Flat battery – replacement
 - Which batteries and which procedure?
 - Using rechargeable batteries
9. **Using a Mains Adapter**
10. **Error Messages**
11. **Safety, Care, Accuracy Test and Disposal**
 - Safety and protection
 - Device care
 - Cleaning the cuff
 - Accuracy test
 - Disposal
12. **Guarantee**
13. **Technical Specifications**
Guarantee Card (see Back Cover)

1. Important Facts about Blood Pressure and Self-Measurement

- **Blood pressure** is the pressure of the blood flowing in the arteries generated by the pumping of the heart. Two values, the **systolic** (upper) value and the **diastolic** (lower) value, are always measured.
- The device indicates the **pulse rate** (the number of times the heart beats in a minute).
- **Permanently high blood pressure values can damage your health and must be treated by your doctor!**
- Always discuss your values with your doctor and tell him/her if you have noticed anything unusual or feel unsure. **Never rely on single blood pressure readings.**
- There are several causes of excessively **high blood pressure values**. Your doctor will explain them in more detail and offer treatment where appropriate. Besides medication, weight loss and exercise can also lower your blood pressure.
- **Under no circumstances should you alter the dosages of any drugs prescribed by your doctor!**
- Depending on physical exertion and condition, blood pressure is subject to wide fluctuations as the day progresses. **You should therefore take your measurements in the same quiet conditions and when you feel relaxed!** Take at least two readings every time (in the morning and in the evening) and average the measurements.
- It is quite normal for two measurements taken in quick succession to produce significantly **different results**. Therefore we recommend using the MAM technology.
- **Deviations** between measurements taken by your doctor or in the pharmacy and those taken at home are quite normal, as these situations are completely different.
- **Several measurements** provide much more reliable information about your blood pressure than just one single measurement. Therefore we recommend using the MAM technology.
- **Leave a small break** of at least 15 seconds between two measurements.
- If you suffer from an **irregular heartbeat**, measurements taken with this device should be evaluated with your doctor.
- **The pulse display is not suitable for checking the frequency of heart pacemakers!**
- If you are **pregnant**, you should monitor your blood pressure very closely as it can change drastically during this time!

☞ This monitor is specially tested for use in pregnancy and pre-eclampsia. When you detect unusual high readings in pregnancy, you should measure again after 4 hours. If the reading is still too high, consult your doctor or gynecologist.

How do I evaluate my blood pressure?

Table for classifying home blood pressure values in adults in accordance with the international Guidelines (ESH, AHA, JSH). Data in mmHg.

Range	Systolic	Diastolic	Recommendation
blood pressure too low	↓ 100	↓ 60	Consult your doctor
1. blood pressure optimum	100 - 130	60 - 80	Self-check
2. blood pressure elevated	130 - 135	80 - 85	Self-check
3. blood pressure too high	135 - 160	85 - 100	Seek medical advice
4. blood pressure dangerously high	160 ↑	100 ↑	Urgently seek medical advice!

The higher value is the one that determines the evaluation.

Example: a blood pressure value of **140/80** mmHg or a value of **130/90** mmHg indicates «blood pressure too high».

2. Important Facts about Atrial Fibrillation (AF)

What is Atrial Fibrillation (AF)?

Normally, your heart contracts and relaxes to a regular beat. Certain cells in your heart produce electrical signals that cause the heart to contract and pump blood. Atrial fibrillation occurs when rapid, disorganized electrical signals are present in the heart's two upper chambers, called the atria; causing them to contract irregularly (this is called fibrillation). Atrial fibrillation is the most common form of heart arrhythmia. It often causes no symptoms, yet it significantly increases your risk of stroke. You'll need a doctor to help you control the problem.

How does AF impact my family or me?

People with AF have a five-fold higher risk of getting stroke. Since the chance of having a stroke increases with age, AF screening is recommended for people over 65 years and older. However, for people from the age of 50 years with high blood pressure (hypertension), diabetes, coronary heart failure or have had a previous stroke AF screening is also recommended. Early diagnosis of AF followed by adequate treatment can significantly reduce the risk of getting stroke.

In young people AF screening is not recommended as it could generate false positive results and unnecessary anxiety. In addition, young individuals with AF have a relatively low risk of getting stroke as compared to elder people.

For more information please visit our website: www.microlife.com.

Microlife AFIB detection provides a convenient way to screen for AF

Knowing your blood pressure and knowing whether you or your family members have AF can help reduce the risk of stroke. Microlife AFIB detection provides a convenient way to screen for AF whilst taking your blood pressure.

Risk factors you can control

High blood pressure and AF are both considered «controllable» risk factors for strokes. Knowing your blood pressure and knowing whether you have AF is the first step in proactive stroke prevention.

3. Using the Device for the First Time

Inserting the batteries

Switch the lock switch (9) to «unlock» position. The battery compartment (5) is on the bottom of the device. Insert the batteries (4 x 1.5 V, size AAA), thereby observing the indicated polarity.

Selecting the correct cuff

Microlife offers different cuff sizes. Select the cuff size to match the circumference of your upper arms (measured by close fitting in the centre of the upper arm).

Cuff size	for circumference of upper arm
S	17 - 22 cm
M	22 - 32 cm
M - L	22 - 42 cm
L	32 - 42 cm
L - XL	32 - 52 cm

☞ Only use Microlife cuffs.

- ▶ Contact your local Microlife Service if the enclosed cuff (6) does not fit.
- ▶ Connect the cuff to the device by inserting the cuff connector (7) into the cuff socket (3) as far as it will go.
- ▶ Spare part cuffs are delivered with different cuff connectors (7). If you exchange/replace the cuff for this device please ensure that is the same connector as the one supplied with the original cuff.

Select the measuring mode: standard or MAM mode

This device enables you to select either standard (standard single measurement) or MAM mode (automatic triple measurement). To select standard mode, slide the MAM switch ⑧ on the side of the device downwards to position «1» and to select MAM mode, slide this switch upwards to position «3».

MAM mode

In MAM mode, 3 measurements are automatically taken in succession and the result is then automatically analysed and displayed. Because the blood pressure constantly fluctuates, a result determined in this way is more reliable than one produced by a single measurement.

- When you select the 3 measurements, the MAM-symbol ⑨ appears in the display.
- The bottom, right hand section of the display shows a 1, 2 or 3 to indicate which of the 3 measurements is currently being taken.
- There is a break of 15 seconds between the measurements (15 seconds are adequate according to «Blood Pressure Monitoring, 2001, 6:145-147» for oscillometric instruments). A count down indicates the remaining time.
- The individual results are not displayed. Your blood pressure will only be displayed after all 3 measurements are taken.
- Do not remove the cuff between measurements.
- If one of the individual measurements was questionable, a fourth one is automatically taken.

 Microlife AFIB is also activated in standard mode. If the device detects AF in standard mode, the cuff pressure will stop at a level of approx. 60 mmHg to receive more data. The hourglass ⑫ will appear in the display.

4. Taking a Blood Pressure Measurement using this Device

Checklist for taking a reliable measurement

1. Avoid activity, eating or smoking immediately before the measurement.
2. Sit down for at least 5 minutes before the measurement and relax.
3. **Always measure on the same arm** (normally left). It is recommended that doctors perform double arm measurements on a patient's first visit in order to determine which arm to measure in the future. The arm with the higher blood pressure should be measured.
4. Remove close-fitting garments from the upper arm. To avoid constriction, shirt sleeves should not be rolled up - they do not interfere with the cuff if they are laid flat.

5. Always ensure that the correct cuff size is used (marking on the cuff).

- Fit the cuff closely, but not too tight.
 - Make sure that the cuff is positioned 2 cm above the elbow.
 - The **yellow artery mark** on the cuff (ca. 3 cm long bar) must lie over the artery which runs down the inner side of the arm.
 - Support your arm so it is relaxed.
 - Ensure that the cuff is at the same height as your heart.
6. Slide the lock switch ⑨ down to the «unlock» position. Press the START/STOP button ① to start measuring.
 7. The cuff will now pump up automatically. Relax, do not move and do not tense your arm muscles until the measurement result is displayed. Breathe normally and do not talk.
 8. When the correct pressure is reached, the pumping stops and the pressure falls gradually. If the required pressure was not reached, the device will automatically pump some more air into the cuff.
 9. During the measurement, the pulse indicator ⑬ flashes in the display.
 10. The result, comprising the systolic ⑩ and the diastolic ⑪ blood pressure and the pulse rate ⑫ is displayed. Note also the explanations on further display symbols in this booklet.
 11. When the device has finished measuring, remove the cuff.
 12. Switch off the device. (The monitor does switch off automatically after approx. 1 min.).

 You can stop the measurement at any time by pressing the START/STOP button (e.g. if you feel uneasy or an unpleasant pressure sensation).

 **If the systolic blood pressure is known to be very high**, it can be an advantage to set the pressure individually. Press the START/STOP button after the monitor has been pumped up to a level of approx. 30 mmHg (shown on the display). Keep the button pressed until the pressure is about 40 mmHg above the expected systolic value – then release the button.

5. Appearance of the Atrial Fibrillation Indicator for early Detection

This device is able to detect atrial fibrillation (AF). This symbol ⑰ indicates that atrial fibrillation was detected during the measurement. Please refer to the next paragraph for information regarding the consultation with your doctor.

Information for the doctor on frequent appearance of the atrial fibrillation indicator

This device is an oscillometric blood pressure monitor that also analyses pulse irregularity during measurement. The device is clinically tested.

The AFIB symbol is displayed after the measurement, if atrial fibrillation occurred during measuring. If the AFIB symbol appears after having performed a blood pressure measurement, the patient is advised to perform another measurement. If the AFIB symbol appears again, we recommend the patient to seek medical advice.

The device does not replace a cardiac examination, but serves to detect atrial fibrillation that often remains undiagnosed until stroke occurs.

- ☞ Keep the arm still during measuring to avoid false readings.
- ☞ This device may not detect atrial fibrillation in people with pacemakers or defibrillators.

6. Traffic Light Indicator in the Display

The bars on the left-hand edge of the display (14) show you the range within which the indicated blood pressure value lies. Depending on the height of the bar, the readout value is either within the optimum (green), elevated (yellow), too high (orange) or dangerously high (red) range. The classification corresponds to the 4 ranges in the table as defined by the international guidelines (ESH, AHA, JSH), as described in «Section 1.».

7. Data Memory

This device always stores the last result at the end of the measurement. To recall the reading, press and hold the START/STOP button (1) while the device is switched off. All display elements are shown now. Release the button when the stored result with the letter «M» (15) is displayed.

8. Battery Indicator and Battery change

Low battery

When the batteries are approximately ¾ empty the battery symbol (13) will flash as soon as the device is switched on (partly filled battery displayed). Although the device will continue to measure reliably, you should obtain replacement batteries.

Flat battery – replacement

When the batteries are flat, the battery symbol (13) will flash as soon as the device is switched on (flat battery displayed). You cannot take any further measurements and must replace the batteries.

1. Open the battery compartment (5) on the bottom of the device.
2. Replace the batteries – ensure correct polarity as shown by the symbols in the compartment.

Which batteries and which procedure?

- ☞ Use 4 new, long-life 1.5 V, size AAA alkaline batteries.
- ☞ Do not use batteries beyond their date of expiry.
- ☞ Remove batteries if the device is not going to be used for a prolonged period.

Using rechargeable batteries

- You can also operate this device using rechargeable batteries.
- ☞ Only use «NiMH» type reusable batteries.
 - ☞ Batteries must be removed and recharged when the flat battery symbol appears. They should not remain inside the device as they may become damaged (total discharge as a result of low use of the device, even when switched off).
 - ☞ Always remove the rechargeable batteries if you do not intend to use the device for a week or more.
 - ☞ Batteries cannot be charged in the blood pressure monitor. Recharge batteries in an external charger and observe the information regarding charging, care and durability.

9. Using a Mains Adapter

You can operate this device using the Microlife mains adapter (DC 6V, 600 mA).

- ☞ Only use the Microlife mains adapter available as an original accessory appropriate for your supply voltage.
- ☞ Ensure that neither the mains adapter nor the cable are damaged.

1. Plug the adapter cable into the mains adapter socket (4) in the blood pressure monitor.
 2. Plug the adapter plug into the wall socket.
- When the mains adapter is connected, no battery current is consumed.

10. Error Messages

If an error occurs during the measurement, the measurement is interrupted and an error message, e.g. «ERR 3», is displayed.

Error	Description	Potential cause and remedy
«ERR 1»	Signal too weak	The pulse signals on the cuff are too weak. Re-position the cuff and repeat the measurement.*
«ERR 2» 20	Error signal	During the measurement, error signals were detected by the cuff, caused for instance by movement or muscle tension. Repeat the measurement, keeping your arm still.
«ERR 3» 18	No pressure in the cuff	An adequate pressure cannot be generated in the cuff. A leak may have occurred. Check that the cuff is correctly connected and is not too loose. Replace the batteries if necessary. Repeat the measurement.
«ERR 5»	Abnormal result	The measuring signals are inaccurate and no result can therefore be displayed. Read through the checklist for performing reliable measurements and then repeat the measurement.*
«ERR 6»	MAM Mode	There were too many errors during the measurement in MAM mode, making it impossible to obtain a final result. Read through the checklist for performing reliable measurements and then repeat the measurement.*
«HI»	Pulse or cuff pressure too high	The pressure in the cuff is too high (over 299 mmHg) OR the pulse is too high (over 200 beats per minute). Relax for 5 minutes and repeat the measurement.*
«LO»	Pulse too low	The pulse is too low (less than 30 beats per minute). Repeat the measurement.*

* Please consult your doctor, if this or any other problem occurs repeatedly.

 If you think the results are unusual, please read through the information in «Section 1.» carefully.

11. Safety, Care, Accuracy Test and Disposal

Safety and protection

- This device may only be used for the purposes described in these instructions. The manufacturer cannot be held liable for damage caused by incorrect application.
- This device comprises sensitive components and must be treated with caution. Observe the storage and operating conditions described in the «Technical Specifications» section.
- Protect it from:
 - water and moisture
 - extreme temperatures
 - impact and dropping
 - contamination and dust
 - direct sunlight
 - heat and cold
- The cuffs are sensitive and must be handled with care.
- Do not exchange or use any other kind of cuff or cuff connector for measuring with this device.
- Only pump up the cuff once fitted.
- Do not use this device close to strong electromagnetic fields such as mobile telephones or radio installations. Keep a minimum distance of 3.3 m from such devices when using this device.
- Do not use this device if you think it is damaged or notice anything unusual.
- Never open this device.
- If the device is not going to be used for a prolonged period the batteries should be removed.
- Read the additional safety information provided within the individual sections of this instruction manual.
- The measurement results given by this device is not a diagnosis. It is not replacing the need for the consultation of a physician, especially if not matching the patient's symptoms. Do not rely on the measurement result only, always consider other potentially occurring symptoms and the patient's feedback. Calling a doctor or an ambulance is advised if needed.



Ensure that children do not use this device unsupervised; some parts are small enough to be swallowed. Be aware of the risk of strangulation in case this device is supplied with cables or tubes.

Device care

Clean the device only with a soft, dry cloth.

Cleaning the cuff

Carefully remove spots on the cuff with a damp cloth and soapsuds.



WARNING: Do not wash the cuff in a washing machine or dishwasher!

Accuracy test

We recommend this device is tested for accuracy every 2 years or after mechanical impact (e.g. being dropped). Please contact your local Microlife-Service to arrange the test (see foreword).

Disposal



Batteries and electronic devices must be disposed of in accordance with the locally applicable regulations, not with domestic waste.

12. Guarantee

This device is covered by a **5 year guarantee** from the date of purchase. The guarantee is valid only on presentation of the guarantee card completed by the dealer (see back) confirming date of purchase or the receipt.

- Batteries and parts that become worn with use are not included.
- Opening or altering the device invalidates the guarantee.
- The guarantee does not cover damage caused by improper handling, discharged batteries, accidents or non-compliance with the operating instructions.
- The cuff has a functional guarantee (bladder tightness) for 2 years. Please contact your local Microlife-Service (see foreword).

13. Technical Specifications

Operating conditions: 10 - 40 °C / 50 - 104 °F

15 - 95 % relative maximum humidity

Storage conditions: -20 - +55 °C / -4 - +131 °F

15 - 95 % relative maximum humidity

Weight: 294.2 g (including batteries)

Dimensions: 160 x 80 x 32 mm

Measuring procedure: oscillometric, corresponding to Korotkoff method: Phase I systolic, Phase V diastolic

Measurement range: 20 - 280 mmHg – blood pressure
30 - 200 beats per minute – pulse

Cuff pressure display range: 0 - 299 mmHg

Resolution: 1 mmHg

Static accuracy: pressure within ± 3 mmHg

Pulse accuracy: ± 5 % of the readout value

Voltage source: 4 x 1.5 V alkaline batteries; size AAA
Mains adapter DC 6V, 600 mA (optional)
approx. 400 measurements
(using new batteries)

Battery lifetime:

IP Class: IP20

Reference to

standards: EN 1060-1 /-3 /-4; IEC 60601-1;
IEC 60601-1-2 (EMC); IEC 60601-1-11

Expected service life: Device: 5 years or 10000 measurements
Accessories: 2 years

This device complies with the requirements of the Medical Device Directive 93/42/EEC.

Technical alterations reserved.