



User manual and installation
Audiometric booth

PRO25

Compliant with regulation **EU 2017/745**
as Medical Device (Class I)

S.N. PXXXXXXXX



Description

Lightweight and transportable solution ready for use in few minutes. Designed for audiometric testing in outpatient clinics, hospitals, audiology centers and industrial environments. Equipped with reversible door with magnetic closure, universal cable passage, external folding table for instruments and lighting. Washable and sanitizable internal surfaces.

This model can be equipped with castors with brakes (optional).

Summary

Description	2
Use and containdications, notice	3
Connection panel for equipment	4
Connection cables for universal connection panels (optional).....	5
Folding table	6
Maintenance and Cleaning	7
Assembly instructions.....	9

Use and contraindications, notice

- The sound-proof booth can be used only for audiometric examinations or similar and not for other medical purposes with applied components (i.e. electrodes) to the patient. It is necessary having different specifications in this case.
- The booth must be used only by trained personnel.
- Man performing the test must always see the patient inside the booth.
- It is forbidden to smoke and to light any flame inside the booth.
- The wrong booth installation or the position near-by flammable materials disclaim all manufacturer responsibilities.

PUMA srl disclaims any responsibility for misuse, incorrect re-installation or improper use of the booth.

Warnings:

Connect the booth to an adequate electrical implant and compliant with the norm CEI 64-8; the plug must be inserted in a 230V electrical socket, protected against overload and short circuit and with differential switch.

The silent booth cannot be installed in places classified with "explosion hazard" (EN 60079-10-1 and EN 60079-10-2) and in rooms "used for medical use" classified as group 2 (CEI 64-8 standard / 710 art. 710.2.7).

Installation is permitted in "ordinary" rooms and in "medical" rooms classified as group 1 (CEI 64-8 / 710 art. 710.2.6); the power supply must happen with an automatic switch with a sensitivity differential of 30 mA of "type AC", 230V.

Please note that the environmental electrical system must comply with the law.

notice

According to the regulation EU 2017/745, annex 1, section III, paragraph 23.4, we advise you to report any incident related to the use of the medical device both to the competent authority of the state in which it is used, and to us as manufacturers at the following address: info@pumasrl.it

Connection panel for equipment

The new connecting panels allow:

- Direct contact between the booth internal and external equipment without further interruptions or type jack connections.
- Fast replacement of equipment with different connections.
- The ability to add cables through.

Mounting



1) Remove the lid seals acting on the two screws by rotating with Allen key which is provided. Do the same action inside the booth.



2) Place the cables of all the appliances through the central hole.



3) After placing them, let them fall and close both the lids (external and internal) previously removed. Now tighten the screws with the Allen key.



4) Connect the selected equipment

Connection cables for universal connection panels (optional)



Tripolar connection jack cables fully insulated allowing an immediate connection with the main audiometric instruments between the inside and the outside of the cabin.
To be used with the universal connection panels.



Jack panel for instruments connection (optional)



A tripolar jack connection plate is available on request. 10 jack inputs, suitable for most of diagnostic and clinical instruments.



Additional double USB port to connect with other instruments or PC.



Folding table

maximum capacity kg 12.

Tilting table has large dimensions and it is suitable for small spaces inside and outside the booth

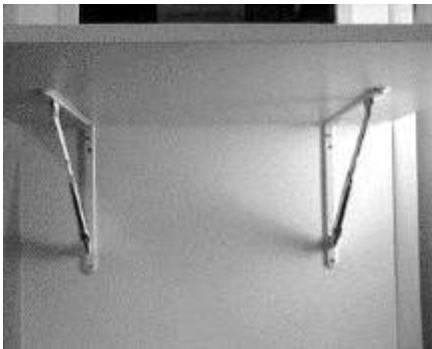

It's supported by two folding shelves and can be easily opened. Easily opening device extending to the rail end.



The safety joints can be blocked in their rails pushing the table down. The supporting blocks in their final position will be straight.

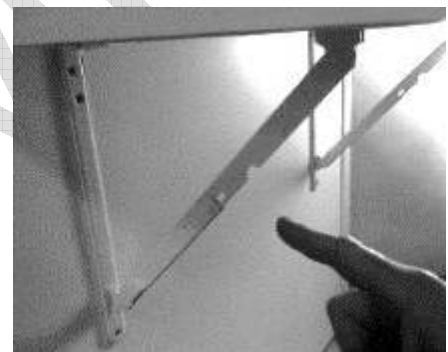

To fold the table, lift it from the open position, then help manually the rails to shut down.

Maintenance and Cleaning

Routine maintenance:

The soundproof booth does not require any specific maintenance. The replacement of the broken lighting device can be performed by trained personnel. (electrician).

Medical rooms maintenance and periodical check-ups:

The maintenance of electrical systems should be committed to qualified companies which have the technical and professional requirements according to the DM 37 of 22.01.2008, art 4.

You should check periodically the system, in details you should check the grounding system efficiency every second year by measuring its resistance value, with reference to what is stated by the IEC 64-710, the medical room systems should be regularly checked by a trained technician. For this reason you should performs the following checks:

- measurement of insulation resistance according to IEC 64-8/6, minimum every two years
- potential equalization at intervals not exceeding three years
- measurement of the resistance of the supplementary equipotential connection at intervals not exceeding three years
- the operation of safety power equipments according to the manufacturer's instructions and in any case at intervals not exceeding one year
- the efficiency of the grounding system at intervals not exceeding two years
- the efficiency of the electrical operation of residual current devices at intervals not exceeding one year

The tests and their results should be recorded in a signed and stamped register by the technical performer with the date of execution of the same.

Cleaning:

The outside of the booth can be cleaned as any furniture.

To clean the internal carpet and the fabric on the walls use specific products commercially available.

Warning:

- The user is the solely responsible for the use the of device and for any consequences deriving there from.
- Do not expose the device or its accessories to liquid or high humidity
- Do not expose the booth to extreme temperatures.
- Avoid exposure to direct sunlight or heat sources. Overheating of electrical components may cause fire or equipment damages.
- The opening or unpacking of all components or any of their accessories, regardless of the reason may cause damage not covered by warranty.
- To avoid electrical shock, do not operate on active or electrified parts. Request the assistance of qualified personnel.
- The replacement of power fuses can be performed only by trained or expert personnel.
- In case of power fuse replacement, the rated current of the device must not be greater than 6 ° g.
- Don't block the ventilation fan when using the booth.
- To dispose used batteries and electrical and electronic components, please observe the local regulations and promote recycling where possible.
- Disposal instructions for old products: Directive on electrical and electronic equipment waste (WEEE Directive) aims to ensure that products are recycled by using best available techniques in treatment, recovery and recycling to ensure people health and an intense environmental protection. Do not dispose of such products together with your household waste. Inform yourself about the local separate collection of waste regarding electrical and electronic equipments marked by this symbol.



- Bring the complete product (including its cables, plugs and accessories) in the designated WEEE collection facilities or to approved landfills.

Assembly instructions

Assembly should be performed by trained personnel. Assembling the booth please follow carefully the drawings. Read all instructions before beginning. The screws and the Allen key as well are provided.

Use screws and Allen key provided.

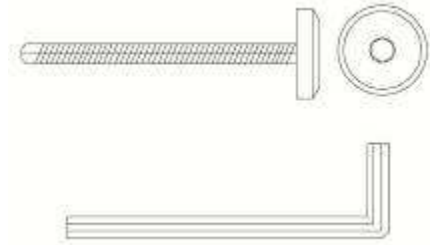

Replacement of the adjustable feet with the castors

NOTE: the cabin is supplied as requested by the customer with adjustable feet or with wheels. However, it is possible to install the castors at a later time by following the procedure below.

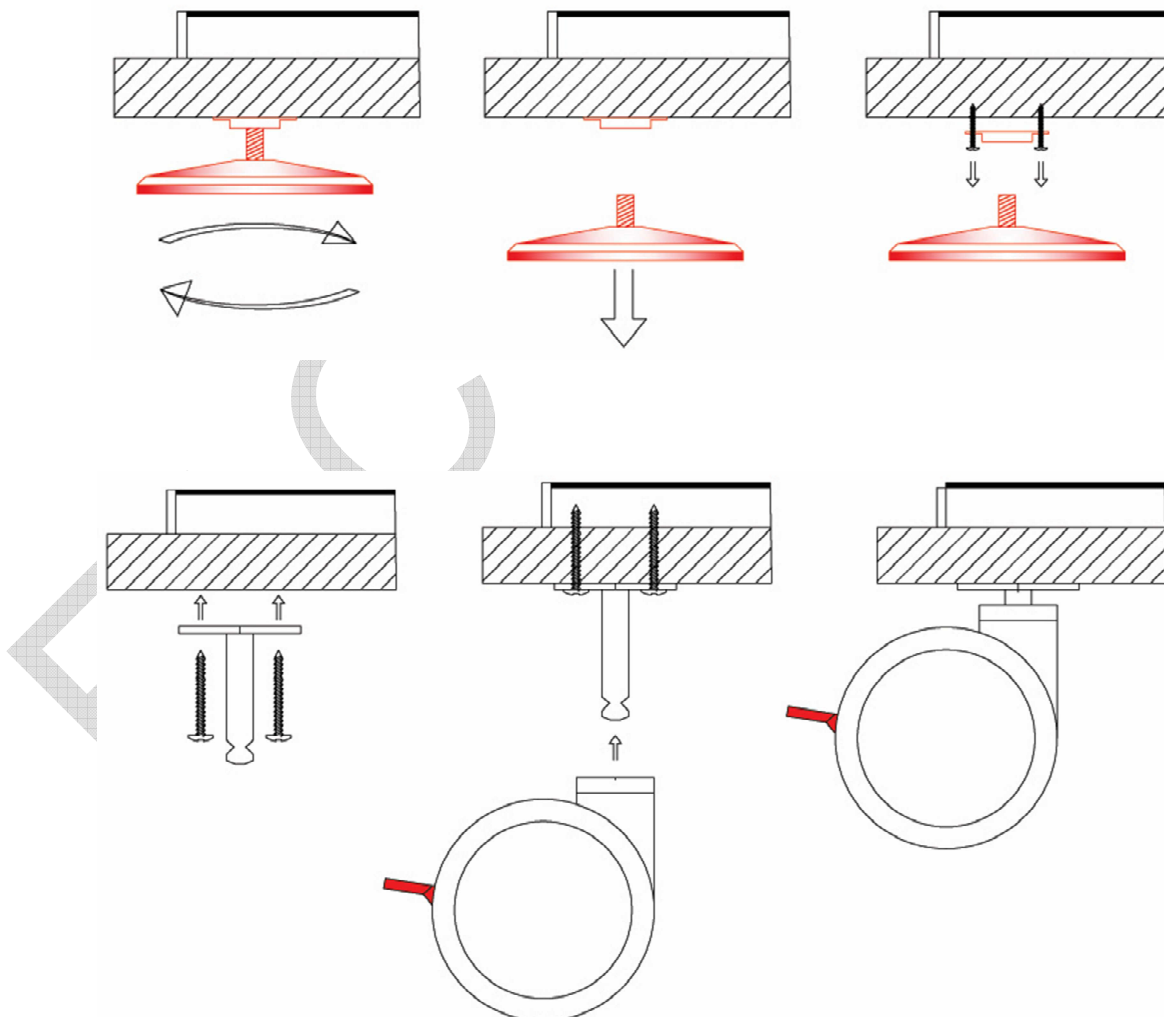

Standard floor with adjustable feet

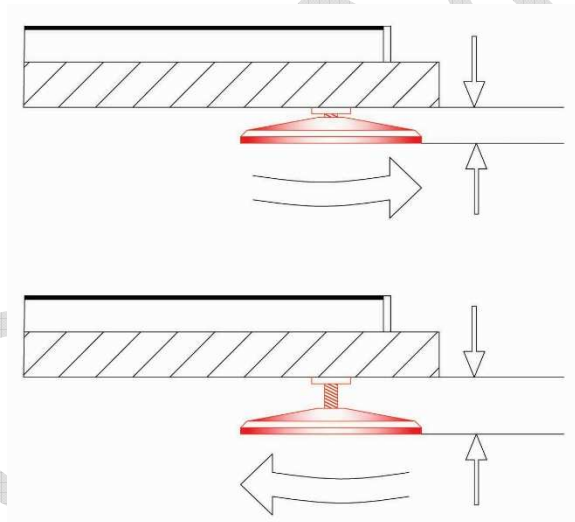
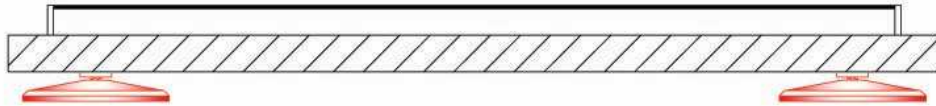

Basement with castors (optional)

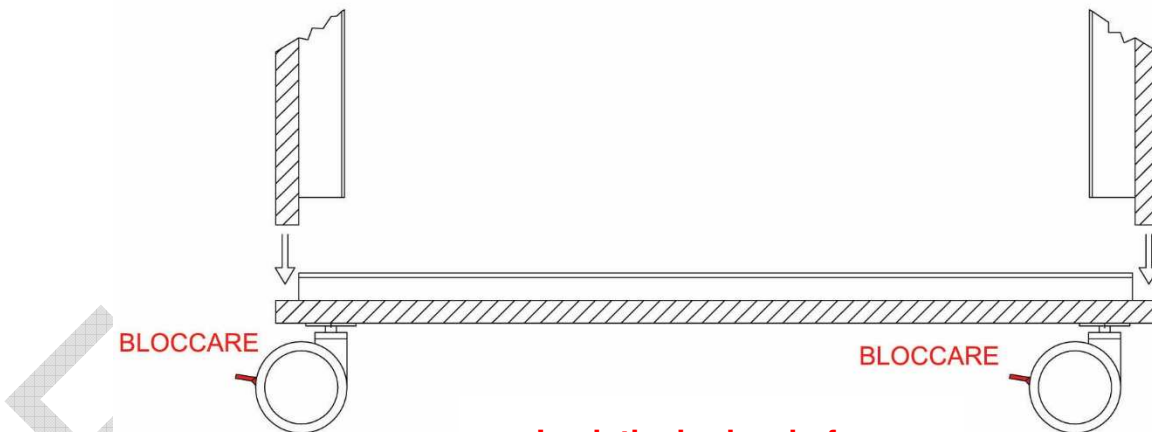
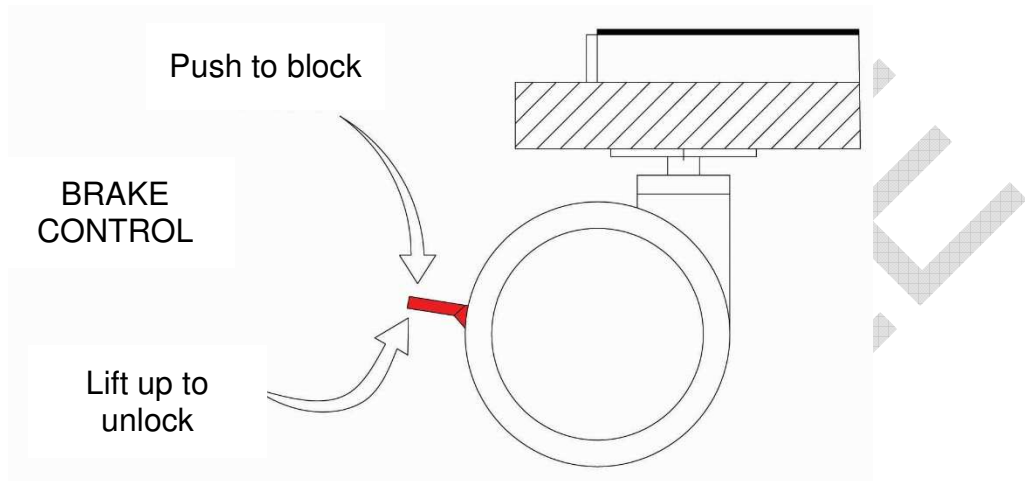

Lock the brakes before mounting!

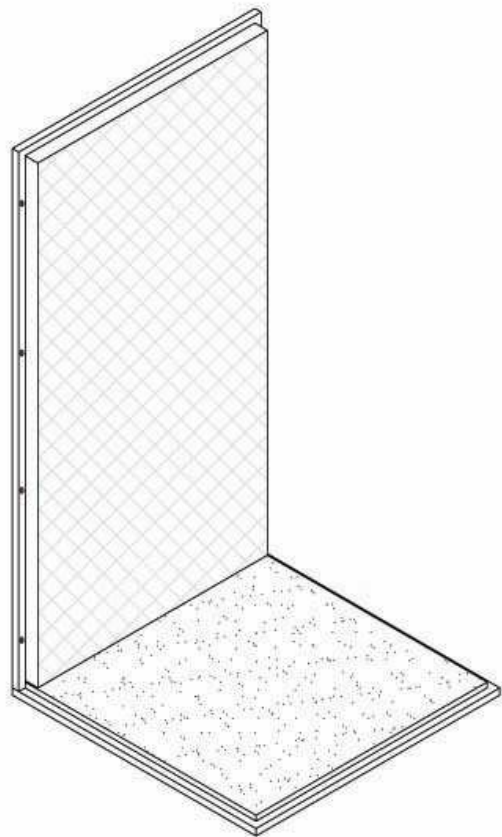
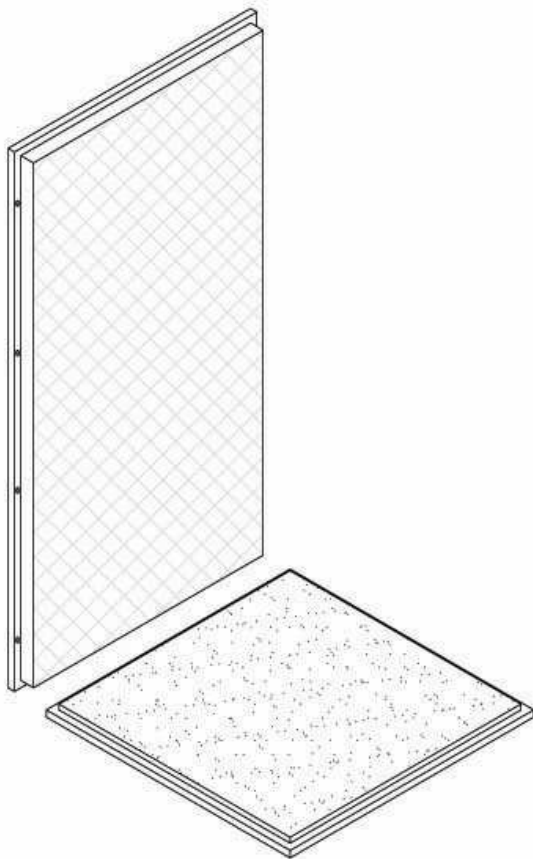
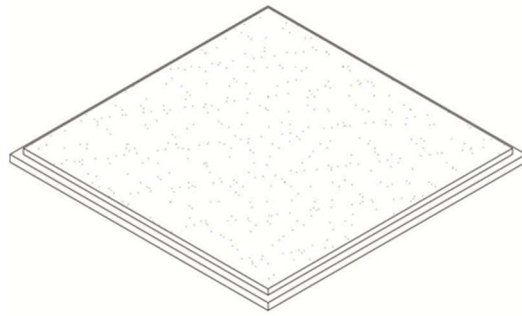

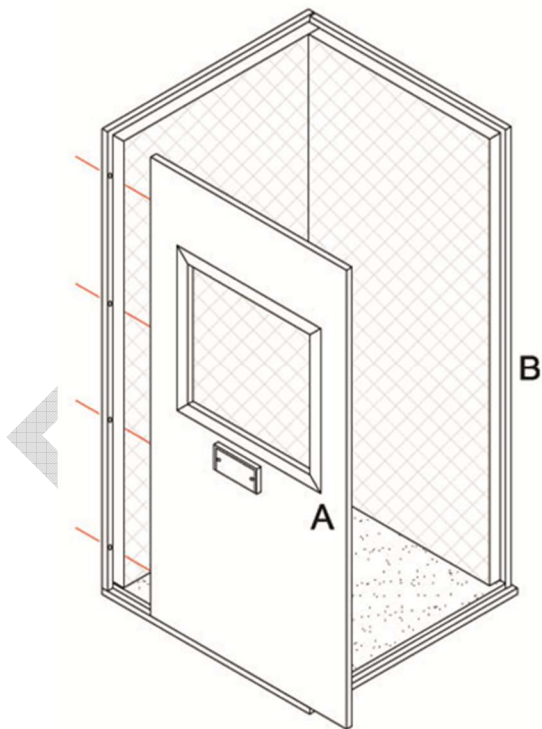
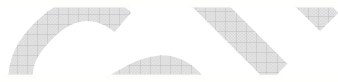
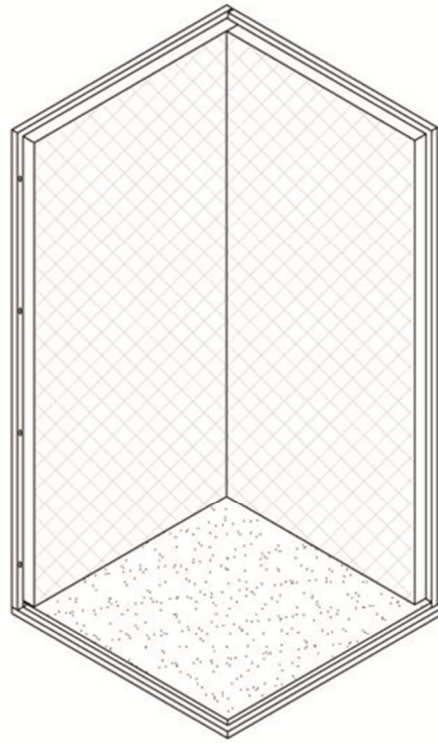
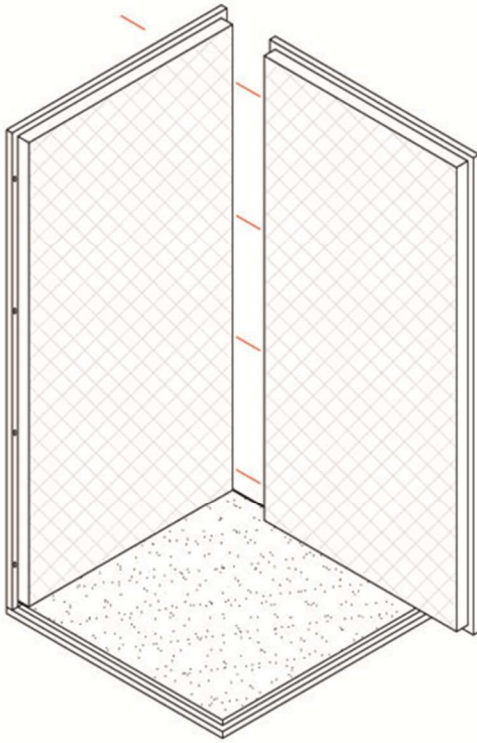

A=B

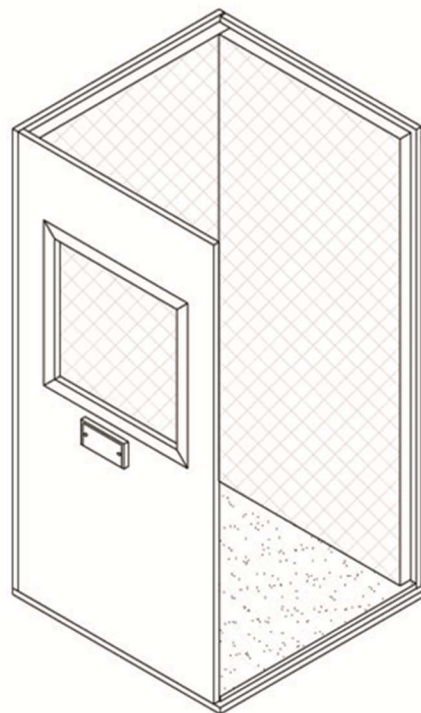

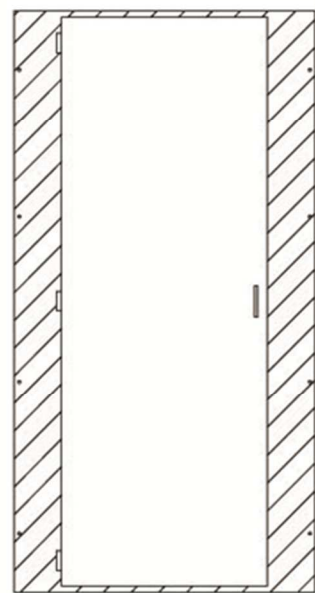
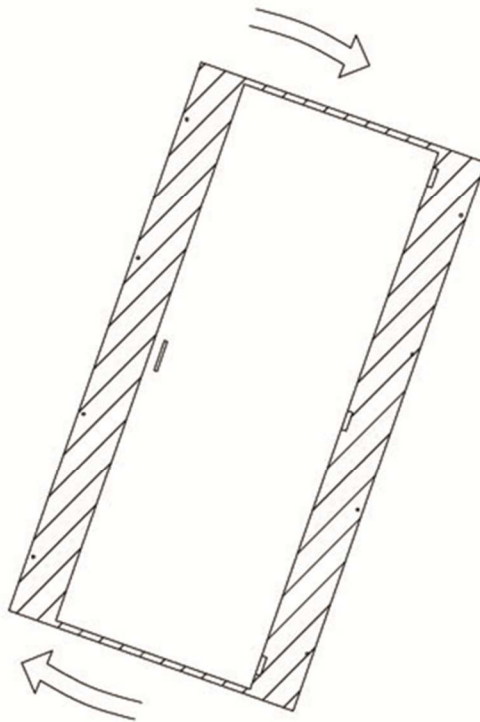
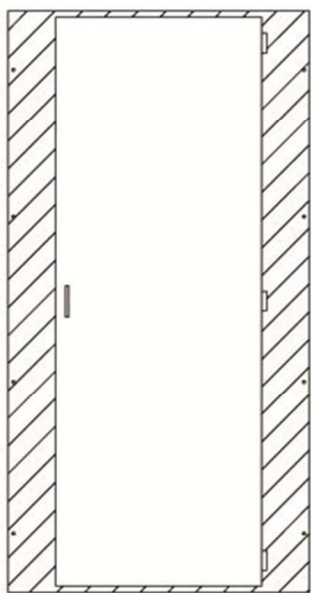
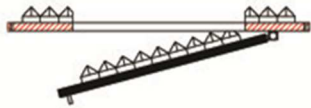
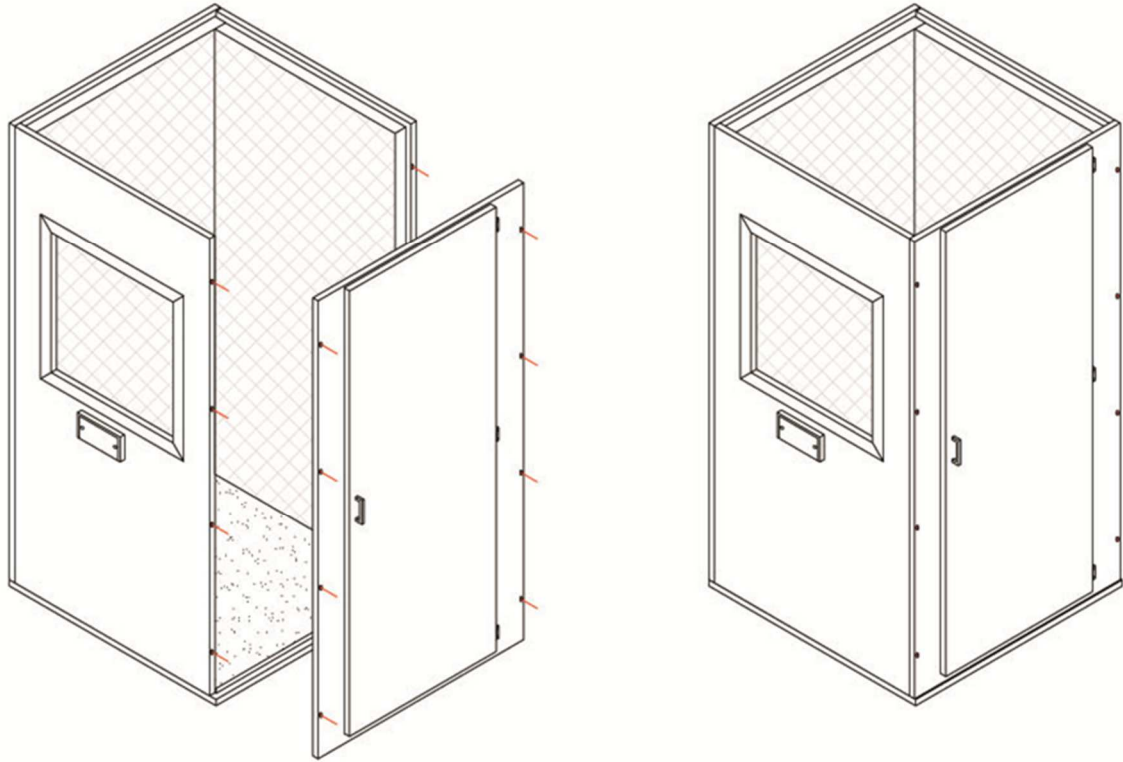

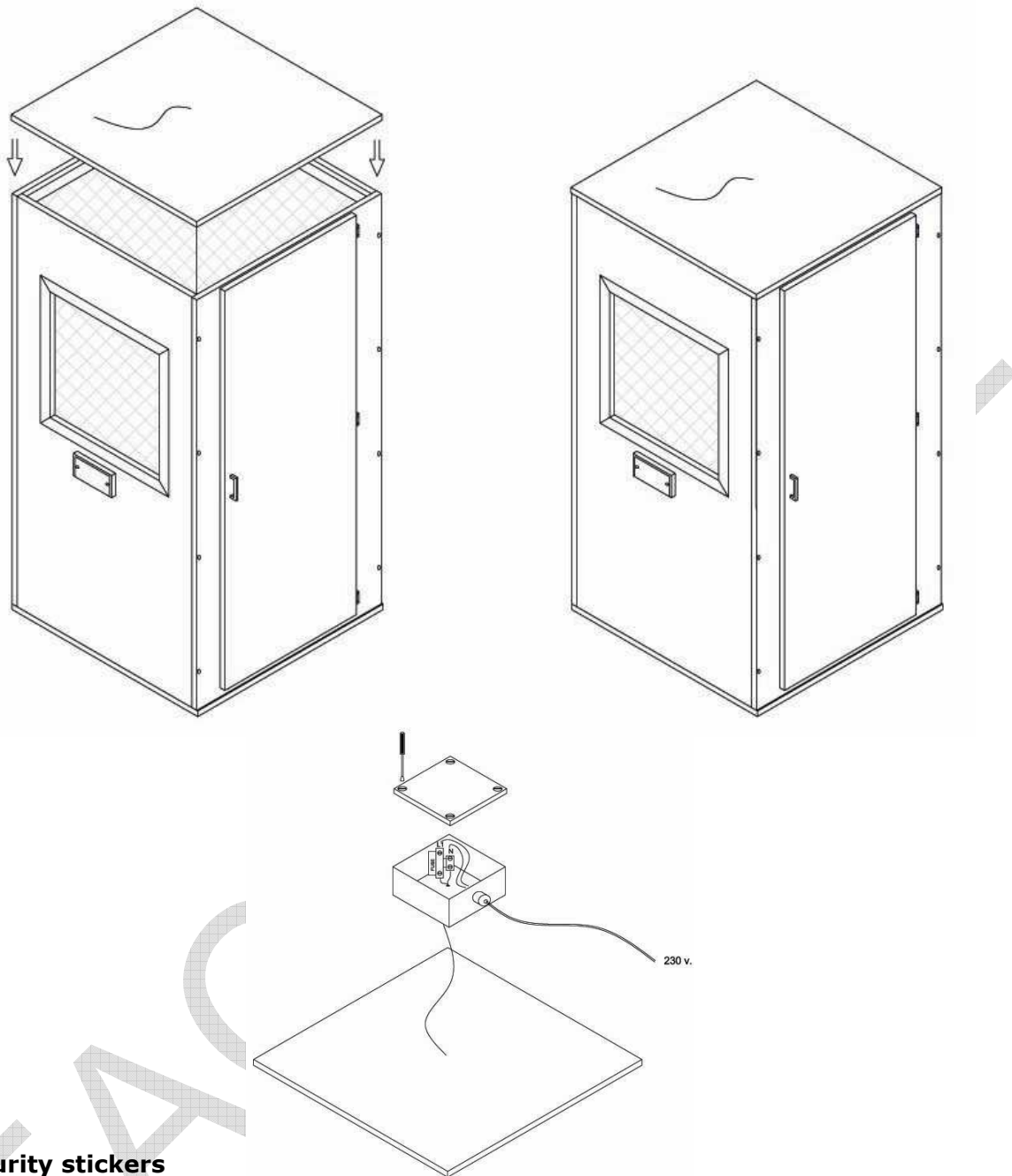

Security stickers

At the end of the operation, apply the warning stickers as follows: place the "ATTENTION TO THE STEP" and "PUSH" symbols at eye level on the inside of the door. Apply the yellow and black band on the step.



Hooks for headphones (internally)

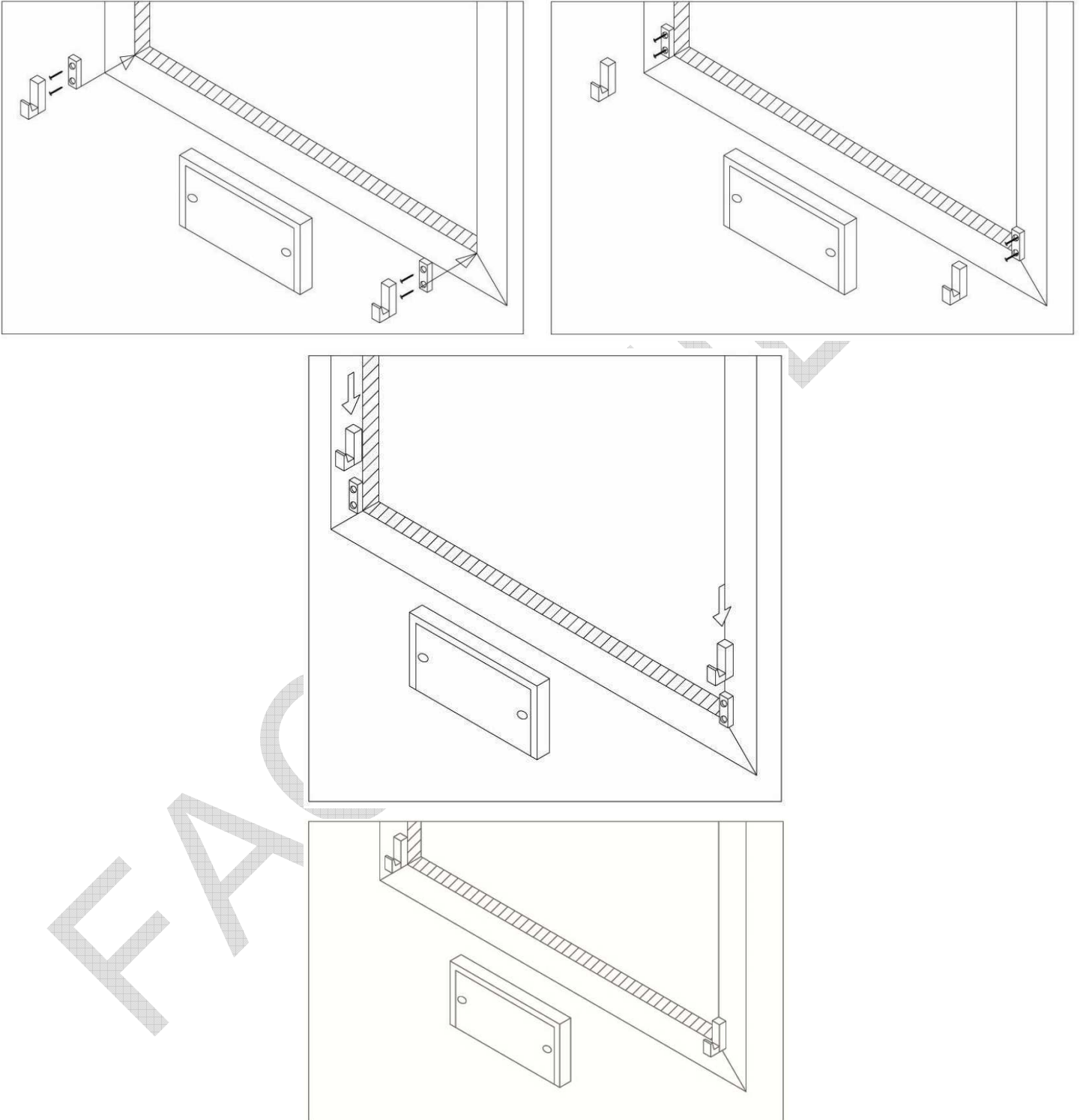

**Electrical implant connection
(only for booths WITHOUT ventilation)**

THIS OPERATION MUST BE CARRIED OUT BY
QUALIFIED STAFF.

PUMA srl declines all responsibility for the
connection of electrical parts if not assembled
by qualified personnel.

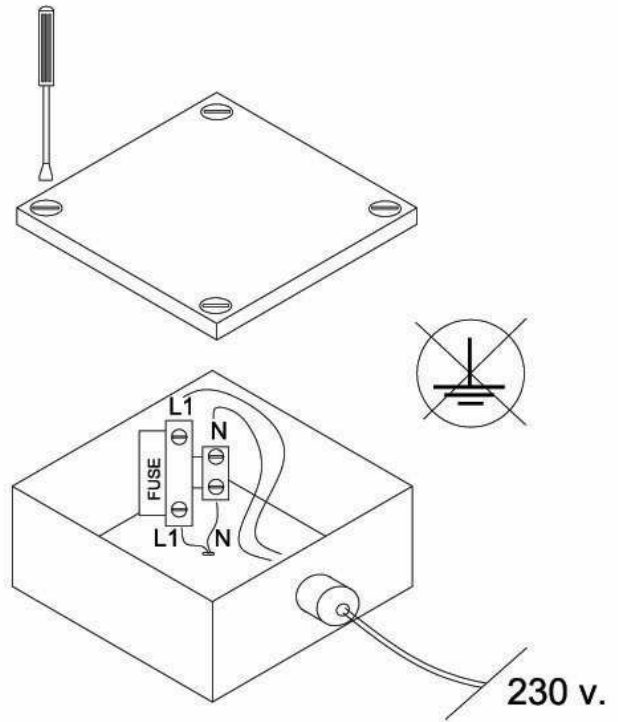

For all versions:

Fuse replacement (5x20-6.3A)

