

**DP-20/DP-20T/DP-21/DP-25/DP-28**

**Digital Ultrasonic Diagnostic  
Imaging System**

**Operator's Manual**

**[Basic Volume]**



# Contents

Intellectual Property Statement .....	I
Responsibility on the Manufacturer Party .....	I
Warranty .....	II
Exemptions.....	II
Customer Service Department.....	II
Important Information .....	III
About This Manual .....	III
Notation Conventions .....	III
Operator's Manuals .....	IV
Manuals on Paper .....	IV
Software Interfaces in this Manual .....	IV
Conventions .....	V
Product Differences.....	V
<b>Safety Precautions .....</b>	<b>VI</b>
Meaning of Signal Words .....	VI
Meaning of Safety Symbols.....	VI
Safety Precautions .....	VI
Latex Alert .....	XIII
Warning Labels.....	XIII
<b>1 Overview.....</b>	<b>1-1</b>
1.1 General.....	1-1
1.2 Product Specifications.....	1-1
1.2.1 Environmental Conditions.....	1-1
1.2.2 Dimensions and Weight.....	1-2
1.3 System Configuration.....	1-2
1.3.1 Standard Configuration .....	1-2
1.3.2 Transducers Available .....	1-2
1.3.3 Optional Parts .....	1-3
1.3.4 Peripherals Supported .....	1-3
1.4 System Introduction.....	1-4
1.4.1 Introduction of Each Unit .....	1-4
1.4.2 I/O Panel.....	1-6
1.4.3 Power Supply Panel .....	1-7
1.4.4 Control Panel .....	1-8
1.4.5 Symbols .....	1-10
<b>2 Preparing the System.....</b>	<b>2-1</b>

2.1	Setup and Connections .....	2-1
2.1.1	Moving and Placing the System .....	2-1
2.1.2	Connecting the Power Cord.....	2-1
2.1.3	Connecting/Disconnecting the Transducers .....	2-2
2.1.4	Connecting/Disconnecting USB device .....	2-3
2.1.5	Connecting a Footswitch.....	2-3
2.1.6	Connecting a Printer .....	2-3
2.1.7	Connecting an External Display.....	2-4
2.1.8	Using the Mobile Power .....	2-4
2.2	Powering ON/OFF .....	2-4
2.2.1	Checking before Powering ON .....	2-4
2.2.2	Powering ON.....	2-5
2.2.3	Restarting.....	2-5
2.2.4	Powering OFF.....	2-5
2.3	Main Interface .....	2-6
2.4	Basic Operations .....	2-7
<b>3</b>	<b>Beginning an Exam.....</b>	<b>3-1</b>
3.1	Entering Patient Information.....	3-1
3.2	Getting Patient Information.....	3-2
3.2.1	iStation .....	3-2
3.2.2	Work List .....	3-3
3.3	Selecting the Exam Mode .....	3-3
3.4	Selecting the Image Mode.....	3-3
3.5	Adjusting the Image.....	3-4
3.5.1	Zooming .....	3-4
3.5.2	Zooming with Thumbnail.....	3-4
3.5.3	Rotating and Flipping the Image.....	3-4
3.5.4	Image Merge.....	3-5
3.6	Cine Review .....	3-5
3.6.1	Cine Review of B Mode .....	3-5
3.6.2	Cine Review of 2B/4B Mode.....	3-6
3.6.3	Cine Review of M/M+B Mode .....	3-6
3.7	Brief Introductions to Measurement .....	3-7
3.7.1	Basic Operations and Buttons .....	3-7
3.7.2	Measurement Items .....	3-8
<b>4</b>	<b>Optimizing the Image.....</b>	<b>4-1</b>
4.1	Basic Operations .....	4-1
4.2	B Mode .....	4-2
4.2.1	Depth .....	4-2

4.2.2	Frequency.....	4-2
4.2.3	Gain .....	4-3
4.2.4	Acoustic Power.....	4-3
4.2.5	TGC .....	4-3
4.2.6	Focus.....	4-4
4.2.7	B/M Dyn Rng (Dynamic Range).....	4-4
4.2.8	Img Enhance (Image Enhance).....	4-5
4.2.9	Frame Avg (Frame Average) .....	4-5
4.2.10	TSI .....	4-5
4.2.11	Scan Mode.....	4-6
4.2.12	IP.....	4-7
4.2.13	B/M Post Process .....	4-7
4.3	M Mode .....	4-8
4.3.1	M Speed.....	4-8
4.3.2	Edge Enhance .....	4-9
4.3.3	M Soften .....	4-9
<b>5</b>	<b>Annotating the Image .....</b>	<b>5-1</b>
5.1	Comments .....	5-1
5.1.1	Adding Comments .....	5-1
5.1.2	Adding Arrow .....	5-2
5.1.3	Moving Comments/Arrows.....	5-2
5.1.4	Editing Comments .....	5-2
5.1.5	Deleting Comments/Arrows .....	5-2
5.2	Body Mark .....	5-3
5.2.1	Adding Body Mark .....	5-3
5.2.2	Moving the Body Mark.....	5-3
5.2.3	Editing the Body Mark .....	5-3
5.2.4	Deleting the Body Mark .....	5-3
<b>6</b>	<b>Auxiliary Functions .....</b>	<b>6-1</b>
6.1	Biopsy Guide .....	6-1
6.1.1	Basic Operations .....	6-1
6.1.2	Adjusting the Guide Line .....	6-1
6.2	Lithotripsy.....	6-2
<b>7</b>	<b>File Management.....</b>	<b>7-1</b>
7.1	Formats of Files.....	7-1
7.2	Saving Files.....	7-1
7.3	File Management.....	7-1
7.4	iVision.....	7-3

<b>8</b>	<b>Probes and Biopsy</b>	<b>8-1</b>
8.1	Probes	8-1
8.1.1	Name and Function of Each Part of the Probe	8-3
8.1.2	Orientation of the Ultrasound Image and the Probe Head	8-5
8.1.3	Procedures for Operating	8-6
8.1.4	Wearing the Probe Sheath	8-9
8.1.5	When the Immersion Method is Used	8-10
8.1.6	Probes Cleaning and Disinfection	8-14
8.1.7	Storage and Transportation	8-17
8.2	Biopsy Guide	8-18
8.2.1	Needle-guided Brackets	8-20
8.2.2	Basic Procedures for Biopsy Guiding	8-25
8.2.3	Needle-guided Bracket Inspection and Installation	8-26
8.2.4	Verifying the Biopsy Guide Line	8-32
8.2.5	Removing the Needle-guided Bracket	8-32
8.2.6	Clean and Sterilize the Needle-guided Bracket	8-34
8.2.7	Storage and Transportation	8-36
8.2.8	Disposal	8-36
<b>9</b>	<b>Preset</b>	<b>9-1</b>
9.1	Basic Operations	9-2
9.2	System Preset	9-2
9.2.1	Region	9-2
9.2.2	General	9-3
9.2.3	Image Preset	9-3
9.2.4	Meas Param	9-4
9.2.5	OB	9-5
9.2.6	Key Config	9-5
9.2.7	Option	9-6
9.3	Exam Preset	9-6
9.3.1	Exam Selection	9-6
9.3.2	Exam Config	9-6
9.4	Image Preset	9-7
9.5	Measure Preset	9-9
9.5.1	Measure	9-9
9.6	Comment Preset	9-10
9.7	DICOM	9-11
9.8	Manage Settings	9-12
9.9	Maintenance	9-12
<b>10</b>	<b>Battery</b>	<b>10-1</b>

10.1	Overview .....	10-1
10.2	Precautions .....	10-2
10.3	Installing and Removing the Batteries.....	10-2
10.4	Battery Status Indicator .....	10-2
10.5	One Full Discharge / Charge Cycle.....	10-3
10.6	Checking Battery Performance .....	10-3
10.7	Battery Disposal .....	10-3
<b>11</b>	<b>Cleaning and Maintaining the System .....</b>	<b>11-1</b>
11.1	Daily Maintenance.....	11-1
11.1.1	Cleaning the System .....	11-1
11.1.2	Backup of Data .....	11-2
11.2	Maintenance Checks by Service Engineer .....	11-2
11.3	Consumables and Periodic Part Replacement .....	11-2
11.4	Troubleshooting.....	11-2
<b>12</b>	<b>Acoustic Output.....</b>	<b>12-1</b>
12.1	Concerns with Bioeffects.....	12-1
12.2	Prudent Use Statement .....	12-1
12.3	ALARA Principle (As Low As Reasonably Achievable).....	12-1
12.4	Derated Ultrasonic Output Parameters.....	12-2
12.5	Measurement Uncertainty .....	12-2
12.6	Parameters Affecting Acoustic Power .....	12-2
12.7	Acoustic Power Setting .....	12-3
12.8	Operations That Change Acoustic Output Power .....	12-3
12.9	References for Acoustic Power and Safety.....	12-4
<b>Appendix A</b>	<b>Accuracy of Measurement .....</b>	<b>A-1</b>
<b>Appendix B</b>	<b>Safety Classification .....</b>	<b>B-1</b>
<b>Appendix C</b>	<b>Guidance and Manufacturer's Declaration .....</b>	<b>C-1</b>
<b>Appendix D</b>	<b>Electrical Safety Inspection .....</b>	<b>D-1</b>







© 2012 Shenzhen Mindray Bio-Medical Electronics Co., Ltd. All rights Reserved.







For this Operator's Manual, the issue date is 2012-09.

## Intellectual Property Statement

SHENZHEN MINDRAY BIO-MEDICAL ELECTRONICS CO., LTD. (hereinafter called Mindray) owns the intellectual property rights to this Mindray product and this manual. This manual may refer to information protected by copyright or patents and does not convey any license under the patent rights or copyright of Mindray, or of others.

Mindray intends to maintain the contents of this manual as confidential information. Disclosure of the information in this manual in any manner whatsoever without the written permission of Mindray is strictly forbidden.

Release, amendment, reproduction, distribution, rental, adaptation, translation or any other derivative work of this manual in any manner whatsoever without the written permission of Mindray is strictly forbidden.

 ,  ,  ,  ,  ,  BeneView, WATO,

BeneHeart,  are the trademarks, registered or otherwise, of Mindray in China and other countries. All other trademarks that appear in this manual are used only for informational or editorial purposes. They are the property of their respective owners.

## Responsibility on the Manufacturer Party

Contents of this manual are subject to change without prior notice.

All information contained in this manual is believed to be correct. Mindray shall not be liable for errors contained herein or for incidental or consequential damages in connection with the furnishing, performance, or use of this manual.

Mindray is responsible for the effects on safety, reliability and performance of this product, only if:

- all installation operations, expansions, changes, modifications and repairs of this product are conducted by Mindray authorized personnel;
- the electrical installation of the relevant room complies with the applicable national and local requirements; and
- the product is used in accordance with the instructions for use.

### **Note**

This equipment must be operated by skilled/trained clinical professionals.

### **Warning**

It is important for the hospital or organization that employs this equipment to carry out a reasonable service/maintenance plan. Neglect of this may result in machine breakdown or personal injury.

# Warranty

THIS WARRANTY IS EXCLUSIVE AND IS IN LIEU OF ALL OTHER WARRANTIES, EXPRESSED OR IMPLIED, INCLUDING WARRANTIES OF MERCHANTABILITY OR FITNESS FOR ANY PARTICULAR PURPOSE.

## Exemptions

Mindray's obligation or liability under this warranty does not include any transportation or other charges or liability for direct, indirect or consequential damages or delay resulting from the improper use or application of the product or the use of parts or accessories not approved by Mindray or repairs by people other than Mindray authorized personnel.

**This warranty shall not extend to:**

- Malfunction or damage caused by improper use or man-made failure.
- Malfunction or damage caused by unstable or out-of-range power input.
- Malfunction or damage caused by force majeure such as fire and earthquake.
- Malfunction or damage caused by improper operation or repair by unqualified or unauthorized service people.
- Malfunction of the instrument or part whose serial number is not legible enough.
- Others not caused by instrument or part itself.

## Customer Service Department

**Manufacturer:** Shenzhen Mindray Bio-Medical Electronics Co., Ltd.

**Address:** Mindray Building, Keji 12th Road South, High-tech industrial park,  
Nanshan, Shenzhen 518057, P.R.China

**Website:** [www.mindray.com](http://www.mindray.com)

**E-mail Address:** service@mindray.com

**Tel:** +86 755 81888998

**Fax:** +86 755 26582680

**EC-Representative:** Shanghai International Holding Corp. GmbH(Europe)

**Address:** Eiffestraße 80, Hamburg 20537, Germany

**Tel:** 0049-40-2513175

**Fax:** 0049-40-255726

# Important Information

1. It is the customer's responsibility to maintain and manage the system after delivery.
2. The warranty does not cover the following items, even during the warranty period:
  - (1) Damage or loss due to misuse or abuse.
  - (2) Damage or loss caused by Acts of God such as fires, earthquakes, floods, lightning, etc.
  - (3) Damage or loss caused by failure to meet the specified conditions for this system, such as inadequate power supply, improper installation or environmental conditions.
  - (4) Damage or loss due to use of the system outside the region where the system was originally sold.
  - (5) Damage or loss involving the system purchased from a source other than Mindray or its authorized agents.
3. This system shall not be used by persons other than fully qualified and certified medical personnel.
4. Do not make changes or modifications to the software or hardware of this system.
5. In no event shall Mindray be liable for problems, damage, or loss caused by relocation, modification, or repair performed by personnel other than those designated by Mindray.
6. The purpose of this system is to provide physicians with data for clinical diagnosis.  
It is the physician's responsibility for diagnostic procedures. Mindray shall not be liable for the results of diagnostic procedures.
7. Important data must be backed up on external memory media.
8. Mindray shall not be liable for loss of data stored in the memory of this system caused by operator error or accidents.
9. This manual contains warnings regarding foreseeable potential dangers, but you shall always be alert to dangers other than those indicated as well. Mindray shall not be liable for damage or loss that results from negligence or from ignoring the precautions and operating instructions described in this operator's manual.
10. If the manager for this system is changed, be sure to hand over this operator's manual to the new manager.

## About This Manual

This operator's manual describes the operating procedures for digital ultrasonic diagnostic imaging system DP-20/DP-20T/DP-21/DP-25/DP-28. To ensure safe and correct operations, carefully read and understand the manual before operating the system.

## Notation Conventions

In this operator's manual, the following words are used besides the safety precautions (refer to "Safety Precautions"). Please read this operator's manual before using the system.

 <b>CAUTION:</b> The digital ultrasonic diagnostic imaging system is not intended for ophthalmic use. Its use in this clinical specialty is contraindicated.
---

# Operator's Manuals

The operator's manuals consist of manuals for the main unit and manuals for transducers. The English manuals are provided on paper; however, the manuals, which are translated into languages other than English, are provided in CD (Compact Disc).

The content of the operator manual, such as screens, menus or descriptions, may be different from what you see in your system. The content varies depending upon the software version, options and configuration of the system.

## Manuals on Paper

- Operator's Manual [Basic Volume]: Describes the basic functions and operations of the system, safety precautions, exam modes, imaging modes, preset, maintenance and acoustic output, etc.
- Operator's Manual [Advanced Volume]: Describes measurement preset, measurements and calculations, etc.
- Operator's Manual [Acoustic Power Data and Surface Temperature Data]: Contains data tables of acoustic output for transducers.
- Operation Note: Contains quick guide for basic operations of the system.

## Software Interfaces in this Manual

Depending on the software version, preset settings and optional configuration, the actual interfaces may be different from those in this manual.

# Conventions

In this manual, these conventions are used to describe the buttons on the control panel, the items in menu, buttons in dialog box and some basic operations:

- <Buttons>: The angular bracket indicates buttons on control panel.
- [Items in menu and buttons in dialog box]: The square bracket indicates items in menu or buttons in dialog box.
- Click [Items or Button]: Move the cursor to the item or button and press <Set>.
- [Items in Menu]→[Items in Submenu]: Selects a submenu item following the path.
- [Dyn Rng (Value)]: Indicates menu items with parameter, (value) shows the current value of the item.
- <Multifunctional Knob (R)> and <Multifunctional Knob (L)>: Indicate the right and left multifunctional knobs.

# Product Differences

Probes	Produced Models				
	DP-20	DP-20T	DP-21	DP-25	DP-28
35C20EA	√	×	×	×	×
65C15EA	√	√	√	√	×
75L53EA	√	√	√	×	×
65EL60EA	√	√	×	×	×
75LT38EA	√	×	×	×	×

NOTE: √ means the produce is configured with the probe





# Safety Precautions

## Meaning of Signal Words

In this operator's manual, the signal words **⚠DANGER**, **⚠WARNING**, **⚠CAUTION** and **NOTE** are used regarding safety and other important instructions. The signal words and their meanings are defined as follows. Please understand their meaning before reading this manual.

Signal words	Meaning
<b>⚠DANGER</b>	Indicates an imminently hazardous situation that, if not avoided, will result in death or serious injury.
<b>⚠WARNING</b>	Indicates a potentially hazardous situation that, if not avoided, could result in death or serious injury.
<b>⚠CAUTION</b>	Indicates a potentially hazardous situation that, if not avoided, may result in minor or moderate injury.
<b>NOTE</b>	Indicates a potentially hazardous situation that, if not avoided, may result in property damage.

## Meaning of Safety Symbols

Symbols	Description
	Type-BF applied part The ultrasound transducers connected to this system are Type-BF applied parts.
	General warning, caution, risk of danger.
	Patient/user infection due to contaminated equipment. Be careful when performing the cleaning, disinfection and sterilization.
	Patient injury or tissue damage from ultrasound radiation. It is required to practice ALARA when operating ultrasound system.

## Safety Precautions

Please observe the following precautions to ensure patient's and operator's safety when using this system.

**⚠DANGER:** Do not use flammable gasses, such as anesthetic gas or hydrogen, or flammable liquids such as ethanol, near this system and probes, because there is danger of explosion.

**⚠ WARNING:**

1. Do not connect the power plug of this system and power plugs of the peripherals to wall receptacles that meet the ratings indicated on the rating nameplate. Using a multifunctional receptacle may affect the system grounding performance, and cause the leakage current to exceed safety requirements.  
Use the cable provided with this system to connect the printer. Other cables may result in electric shock.  
Only use the power supply provided by Mindray, other power supply such as UPS may result in electric shock.
2. Connect the protective grounding conductor before turning ON the system. Disconnect the grounding cable after turning OFF the system. Otherwise, electric shock may result.
3. For the connection of power and grounding, follow the appropriate procedures described in this operator's manual. Otherwise, there is risk of electric shock. DO NOT connect the grounding cable to a gas pipe or water pipe; otherwise, improper grounding may result or a gas explosion may occur.
4. Before cleaning the system, disconnect the power cord from the outlet. System failure and electric shock may result.
5. This system is not water-proof designed. Do Not use this system in any place where water or any liquid leakage may occur. If any water is sprayed on or into the system, electric shock or device malfunction may result. If water is accidentally sprayed on or into the system, contact Mindray Customer Service Department or sales representative.
6. Do not use a transducer that has a damaged, scratched surface, or exposed wiring of any kind. Immediately stop using the transducer and contact Mindray Customer Service Department or sales representative. There is risk of electric shock if using a damaged or scratched transducer.
7. DO NOT allow the patient to contact the live parts of the ultrasound system or other devices, e.g. signal I / O ports. Electric shock may occur.
8. Do not use an aftermarket probe other than those specified by Mindray. The probes may damage the system causing a profound failure, e.g. a fire in the worst case.
9. Do not subject the transducers to knocks or drops. Use of a defective transducer may cause an electric shock.
10. Do not open the covers and front panel of the system. Short circuit or electric shock may result when the system hardware is exposed and powered on.
11. Do not use this system when any digital device such as a high-frequency electrotome, high-frequency therapeutic device or defibrillator is applied already. Otherwise, there is a risk of electric shock to the patient.
12. When moving the system, you should first fold the keyboard, disconnect the system from other devices (including probes) and disconnect the system from the power supply.

13. **Accessory equipment connected to the analog and digital interfaces must comply with the relevant IEC standards (e.g., IEC 60950 information technology equipment safety standard and IEC 60601-1 medical equipment standard). Furthermore, all configurations must comply with the standard IEC 60601-1-1. It is the responsibility of the person, who connects additional equipment to the signal input or output ports and configures a medical system, to verify that the system complies with the requirements of IEC 60601-1-1. If you have any questions regarding these requirements, consult your vendor.**
14. **Prolonged and repeated use of keyboards may result in hand or arm nerve disorders for some individuals. Observe the local safety or health regulations concerning the use of keyboards.**
15. **When using intra-cavity transducers, do not activate the transducer outside the patient's body.**
16. **This system is not intended for ophthalmic use.**

**⚠ CAUTION:**

1. Precautions concerning clinical examination techniques:
  - (1) This system must be used only by qualified medical professionals.
  - (2) This operator's manual does not describe clinical examination techniques. The clinician should select the proper examination techniques based on specialized training and clinical experience.
2. Malfunctions due to radio wave:
  - (1) If a radio wave emitting device is used in the proximity of this system, it may interfere with operations. Do not bring or use devices that generate radio waves, such as cellular telephones, transceivers, and radio controlled toys, in the room where the system is installed.
  - (2) If a person brings a device that generates radio waves near the system, ask him / her to immediately turn OFF the device.
3. Precautions concerning movement of the system:
  - (1) When you place the system on the mobile trolley and move them together, you must secure all objects on the mobile trolley to prevent them from falling. Otherwise you should separate the system from the mobile trolley and move them individually.
  - (2) When you have to move the system with the mobile trolley upward or downward the stairs, you must separate them first and then move them individually.
  - (3) Object placed on the monitor may fall and injure an individual.
  - (4) Fasten and fully secure any peripheral device before moving the system. A loose peripheral device may fall and injure an individual.
  - (5) Do not expose the system to excessive vibration through transportation. Mechanical damage may result.
  - (6) Always keep the system dry. Avoid transporting this system quickly from a cold place to a warm place; otherwise condensation or water droplets may form allowing a short circuit and possible electric shock.



4. If the circuit protector is tripped, it indicates that the system or a peripheral device was improperly shut down and the system is unstable. You cannot repair the system under this circumstance and must call the Mindray Customer Service Department or sales representative.
5. There is no risk of high-temperature burns during routine ultrasound examinations. It is possible for the surface temperature of the transducer to exceed the body temperature of a patient due to environmental temperature and exam type combinations. If a patient complains of any excessive heat from the transducer, immediately stop scanning. To prevent patient burns, ensure there is no surface damage to the transducer. Do not apply the transducer to the same region on the patient for a long time. Apply the transducer only for a period of time required for the purpose of diagnosis.
6. Do not use the system to examine a fetus for a long period of time.
7. The system and its accessories are not disinfected or sterilized prior to delivery. The operator is responsible for the cleaning and disinfection of transducers and sterilization of biopsy brackets according to the manuals, prior to the use. All items must be thoroughly processed to completely remove harmful residual chemicals or gasses that are harmful to the human body or that may damage the accessory.
8. It is necessary to press <Patient> to end the current scan that is in progress and clear the current Patient Information field. Otherwise new patient data may be combined with the previous patient data.
9. Do not connect or disconnect the system's power cord or its accessories (e.g., a printer) without turning OFF the power first. This may damage the system and its accessories or cause electric shock.
10. Before using the digital ultrasonic diagnostic imaging system to perform an exam, please carefully read "10 Acoustic Output".
11. The cover contains natural rubber latex and talc that can cause allergic reactions in some individuals.
12. Please use the ultrasound gel compliant with the relevant local regulations.
13. Do not connect this system to outlets with the same circuit breakers and fuses that control the current of devices such as life-support systems. If this system malfunctions and generates overcurrent, or when there is an instantaneous current at power ON, the circuit breakers and fuses of the building's supply circuit may be tripped.

- NOTE:**
1. Do not use the system in the vicinity of strong electromagnetic field (such as a transformer), which may affect the performance of the system.
  2. Do not use the system in the vicinity of high-frequency radiation source, which may affect the performance of the system or even lead to failure.
  3. When using or placing the system, keep the system horizontal to avoid disbalance.
  4. To avoid damaging the system, do not use it in following environment:
    - (1) Locations exposed to direct sunlight;
    - (2) Locations subject to sudden changes in environmental temperature;
    - (3) Dusty locations;
    - (4) Locations subject to vibration;
    - (5) Locations near heat generators;
    - (6) Locations with high humidity.
  5. Turn ON the system only after the power has been turned OFF for more than 20 seconds. If the system is turned ON immediately after being turned OFF, the system may not reboot properly and could malfunction.
  6. Do not disconnect a transducer that remains in a live imaging state. This can damage the system and / or transducer. Press [Freeze] key to freeze an image or turn off the power of the system before connecting or disconnecting a transducer.
  7. Remove ultrasound gel from the face of a transducer when the examination is complete. Water in the gel may enter the acoustic lens and adversely affect or damage the transducer array and lens.
  8. You should properly back up the system to a secure external storage media, including system configuration and settings and patient data. Data stored to the system's hard drive may be lost due to system failure, improper operation or accident.
  9. Do not apply external force to the control panel. The system may be damaged.
  10. If the system is used in a small room, the room temperature may rise. Provide proper ventilation and free air exchange.
  11. To dispose of the system or any part, contact Mindray Customer Service Department or sales representative. Mindray is not responsible for any system content or accessories that have been discarded improperly.
  12. To ensure optimal system operations, it is recommended that you maintain the system under a Mindray service agreement. Various aspects of system performance and operation can be maintained under the professional supervision of a service representative.
  13. Do not use gel, disinfectant, transducers or needle-guided brackets that are not compatible with the system.
  14. The replaceable fuse is inside the chassis. Refer replacing job to Mindray service engineers or engineers authorized by Mindray only.
  15. Do not turn OFF the power supply of the system during printing, file storage or invoking other system operations. An interrupted process may not be completed, and can become lost or corrupted.
  16. If the system is powered off improperly during operation, it may result in data damage or system failure.
  17. Do not use a USB memory device (e.g., a USB flash drive, removable hard disk) which has unsafe data. Otherwise system damage may result.
  18. It is recommended to only use the video devices specified in this manual.

- NOTE:**
19. When using this system with portable package, be careful not to block the ventilation slots.
  20. When copying files to USB storage device, do not pull out the USB storage device forcibly, or damage to USB storage device or this system may occur.
  21. Do not connect mobile hard disk with too many partitions.
  22. When sending DICOM files or copying files from USB storage devices, do not press the buttons on the control panel.

Please read the following precautions carefully to ensure the safety of the patient and the operator when using the probes.

- ⚠ WARNING:**
1. **This ultrasonic probe is only for use with the specified ultrasonic diagnostic system. Please refer to “1.3.2 Transducers Available” to select the proper probe.**
  2. **Confirm that the probe and cable are normal before and after each examination. A defective probe may cause electric shock to the patient.**
  3. **Do not subject the probe to shock. A defective probe may cause electric shock to the patient.**
  4. **Do not disassemble the probe to avoid the possibility of electric shock.**
  5. **Never immerse the probe connector into liquids such as water or disinfectant because the connector is not waterproof. Immersion may cause electric shock or malfunction.**
  6. **Ultrasonic probe is only for use with the specified ultrasonic diagnostic system. Please refer the ultrasonic diagnostic system operation manual to select the proper probe.**
  7. **A probe sheath must be installed over the probe before performing intra-cavity or intra-operative examination.**

- ⚠ CAUTION:**
1. **When using the probe, wear sterile gloves to prevent infection.**
  2. **Be sure to use ultrasound gel. Please use the ultrasound gel compliant with the relevant local regulations.**
  3. **In normal diagnostic ultrasound mode, there is no danger of a normal-temperature burn; however, keeping the probe on the same region of the patient for a long time may cause such a burn.**
  4. **Do not use the carrying case for storing the probe. If the carrying case is used for storage, it may become a source of infection.**
  5. **The probe and accessories supplied with it are not delivered disinfected or sterilized. Sterilization (or high-level disinfect) before use is required.**
  6. **It is required to practice ALARA when operating ultrasound system. Minimize the acoustic power without compromising the quality of images.**

7. Disposable components are packaged sterile and are single-use only. Do not use if integrity of packaging violated or if expiration date has passed. Please use the disposable components compliant with the relevant local regulations.
8. Please use the disinfection or sterilization solution that recommended in this operator's manual, otherwise Mindray will not be liable for damage caused by other solutions. If you have any questions, please contact Mindray Customer Service Department or sales representative.
9. Do not use pre-lubricated condoms as a sheath. Lubricant may not be compatible with the transducer material and damage may result.
10. Transducer damage may be caused by inappropriate gel, detergent or cleanser:  
**Do not soak or saturate transducers with solutions containing alcohol, bleach, ammonium chloride compounds, acetone or formaldehyde.**  
**Avoid contact with solutions or coupling gels containing mineral oil or lanolin.**

**NOTE:**

1. Read the following precautions to prevent the probe from malfunction.
  - Before connecting or disconnecting the probe, freeze or turn off the ultrasound diagnostic system.
  - Clean and disinfect the probe before and after each examination.
  - After the examination, wipe off the ultrasound gel thoroughly. Otherwise, the ultrasound gel may solidify and the image quality would be degraded.
2. Ambient conditions:  
To prevent the probe from being damaged, do not use it where it will be exposed to:
  - direct sunlight or X-rays
  - sudden changes in temperature
  - dust
  - excessive vibration
  - heat generatorsUse the probes under the specified ambient conditions.
3. Repeated disinfection will eventually damage the probe, please check the probe's performance periodically.

**NOTE:** The following definition of the WEEE label applies to EU member states only: The use of this symbol indicates that this system should not be treated as household waste. By ensuring that this system is disposed of correctly, you will help prevent bringing potential negative consequences to the environment and human health. For more detailed information with regard to returning and recycling this system, please consult the distributor from whom you purchased the system.



\* For system products, this label may be attached to the main unit only.

# Latex Alert

**⚠️ WARNING:** Allergic reactions in latex (natural rubber) sensitive patients may range from mild skin reactions (irritation) to fatal anaphylactic shock, and may include difficulty in breathing (wheezing), dizziness, shock, swelling of the face, hives, sneezing or itching of the eyes (FDA Medical Alert on latex products, “Allergic Reactions to Latex-containing Medical Devices”, issued on March 29, 1991).

When choosing a transducer sheath, it is recommended that you directly contact CIVCO for obtaining transducer cover, pricing information, samples and local distribution information. For CIVCO information, please contact the following:

CIVCO Medical Instruments

Tel: 1-800-445-6741

[WWW.civco.com](http://WWW.civco.com)





## Warning Labels



The warning labels are attached to this system in order to call your attention to potential hazards.

The symbol ⚠️ on the warning labels indicates safety precautions. The warning labels use the same signal words as those used in the operator’s manual.

Refer to the operator’s manual for detailed information about the warning labels. Read operator’s manual carefully before using the system.

The name, pattern and meaning of each warning label are described as follows:

No.	Label	Meaning
1		Before using the system, be sure to carefully read the relevant content of this operator’s manual.
2	<div style="display: flex; justify-content: space-around; align-items: center;"> <div style="text-align: center;">  <p>a)</p> </div> <div style="text-align: center;">  <p>b)</p> </div> </div>	<p>a) General warning, caution, risk of danger.</p> <p>b) Urges Caution related to handling of the transducers. For handling of the transducers, refer to the transducers’ operator’s manual.</p>
3		Cautions that the system must not be removed covers because the high voltage may cause electric shock.

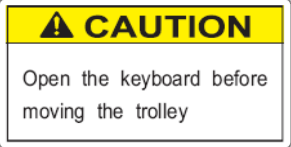
No.	Label	Meaning
4	<p>The following labels are available when the system works with the mobile trolley.</p> <div style="display: flex; justify-content: space-around; align-items: center;"> <div style="text-align: center;">  <p>(a)</p> </div> <div style="text-align: center;">  <p>(b)</p> </div> </div>	<p>(a) DO NOT sit on the system.  (b) DO NOT push the trolley when the casters are locked.</p>
5		<p>This label is available when the system works with the mobile trolley.  Open the keyboard before moving the trolley.</p>

# 1 Overview

---

This system is intended for use in gynecology, obstetrics, abdominal, pediatric, small organ, cephalic, transcranial, musculo-skeletal, cardiac, vascular, urology, orthopedics intraoperative and nerve exams.

## 1.1 General

- Intended Use: DP-20/DP-20T/DP-21/DP-25/DP-28 digital ultrasonic diagnostic imaging system is applicable for ultrasonic exams of human body.
- Contraindication: none.
- Product and Model Code

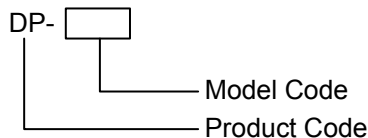

**NOTE:** The functions described in the operator's manual may vary depending upon the specific system you purchased.

## 1.2 Product Specifications

### 1.2.1 Environmental Conditions

- Power Supply

**Voltage:** 100-240V~  
**Frequency:** 50/60Hz  
**Input current:** 1.0-0.5A  
**Fuse** 250V~ T3.15AH

- Environment conditions

	Operating	Storage and transportation
<b>Ambient temperature:</b>	0°C~40°C	-20°C~55°C
<b>Relative humidity:</b>	30%~85% (no condensation)	30%~95% (no condensation)
<b>Atmospheric pressure:</b>	700hPa~1060hPa	700hPa~1060hPa

**⚠WARNING:** Do not use this system in the conditions other than those specified.

## 1.2.2 Dimensions and Weight

- External dimensions: 290mm×354mm×161mm (Width×Height×Depth)
- Net weight: <6kg (without the battery and accessories)

## 1.3 System Configuration

### 1.3.1 Standard Configuration

- Main unit
- Accessories
  - Operator's manual
  - Gel
  - Power cord of the main unit
  - Probe holder
  - Gel holder
  - Remote cable of printer
  - Multilingual controls overlay

### 1.3.2 Transducers Available

No.	Probe Model	Category	Intended Use	Region Applied
1.	35C20EA	Convex	Gynecology, Obstetrics, Abdominal, Pediatric, Cardiac, Vascular, Musculo-skeletal, Nerve	Body surface
2.	35C50EB	Convex	Gynecology, Obstetrics, Pediatric, Abdominal, Vascular, Musculo-skeletal, Urology, Nerve	Body surface
3.	65C15EA	Convex	Abdominal, Pediatric, Cephalic, Transcranial, Musculo-skeletal, Cardiac, Vascular, Nerve	Body surface
4.	65EC10EB	Convex	Gynecology, Obstetrics, Urology, Pediatric, Cephalic	Transvaginal Transrectal
5.	65EL60EA	Linear	Urology	Transrectal
6.	75L38EB	Linear	Pediatric, Abdominal, Small organ, Cephalic, Vascular, Musculo-skeletal, Orthopedics, Nerve	Body surface
7.	75L53EA	Linear	Pediatric, Abdominal, Small organ, Cephalic, Vascular, Musculo-skeletal, Orthopedics, Nerve	Body surface



No.	Probe Model	Category	Intended Use	Region Applied
8.	75LT38EA	Linear	Pediatric, Abdominal, Intraoperative, Small organ, Musculo-skeletal, Vascular, Orthopedics, Nerve	Body surface Intro-operative

### 1.3.3 Optional Parts

No.	Name	Model or Description
1	DICOM software	DICOM3.0
2	Mobile trolley	UMT-110
3	Portable package	/
4	Foot switch	971-SWNOM
5	Keyboard dust-proof cover	/
6	Dual-transducer socket	/
7	Hard disk	Configured in factory
8	Battery pack	/
9	Needle-guided bracket	/

### 1.3.4 Peripherals Supported

No.	Name	Model
1	Graph/text printer (USB port)	HP Photosmart D5368 HP Business Inkjet 1200 HP DeskJet 1280 HP DeskJet 3820 HP DeskJet 5650 HP DeskJet 6548
2	Video printer	MITSUBISHI P93W MITSUBISHI P93W-Z SONY UP-895MD SONY UP-897MD
3	USB removable storage device	
4	Footswitch	

**⚠WARNING:** This system complies with IEC60601-1-2: 2007 and its RF emission meets the requirements of CISPR11 Class B. In a domestic environment, the customer or the user should guarantee to connect the system with Class B peripheral devices; otherwise RF interference may result and the customer or the user must take adequate measures accordingly.

**NOTE:** For any question about choice and use of the printers, contact Mindray customer service department.

## 1.4 System Introduction

**NOTE:** The illustrations in the manual are for reference only. What appears in the illustrations may vary depending upon the specific system you purchased.

### 1.4.1 Introduction of Each Unit

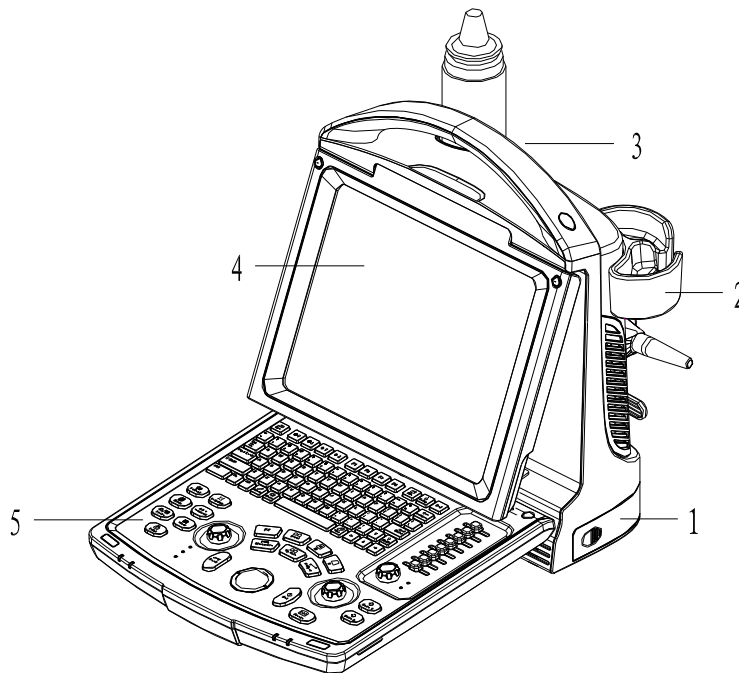

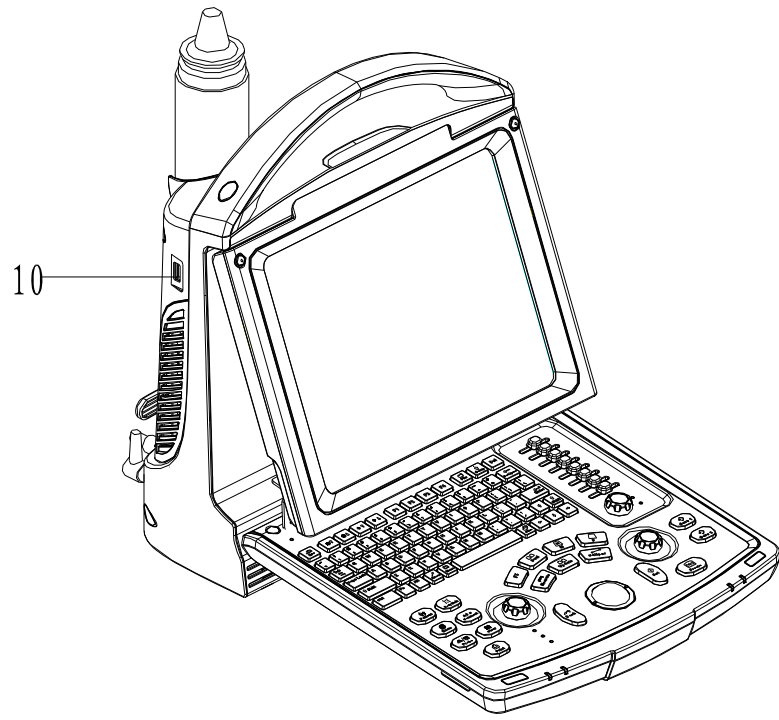
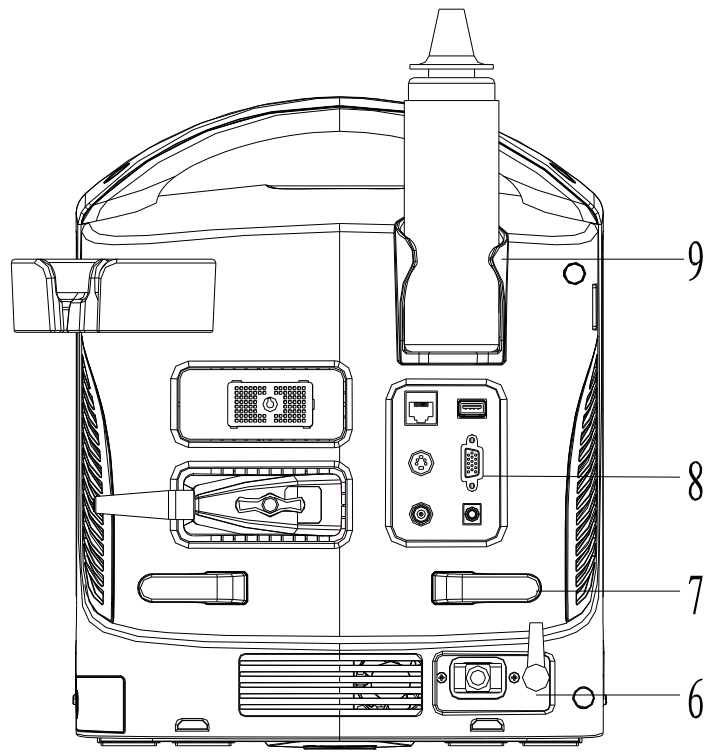

No.	Name	Function
1	Battery cover	Used to hold the battery
2	Probe holder	Used to place probes temporarily
3	Handle	Used to lift the machine

No.	Name	Function
4	LED monitor	Used to displays the image and parameters
5	Control Panel	Refer to 1.4.4 Control Panel
6	Power Supply Panel	Electric interface panel, refer to 1.4.3 Power Supply Panel
7	Winding rack	Used to wind the power cord.
8	I/O Panel	Refer to 1.4.2 I/O Panel
9	Gel holder	Used to place the ultrasound gel temporarily.
10	USB ports	Used to connect USB devices.

## 1.4.2 I/O Panel

The I/O panel locates at the back of the system.

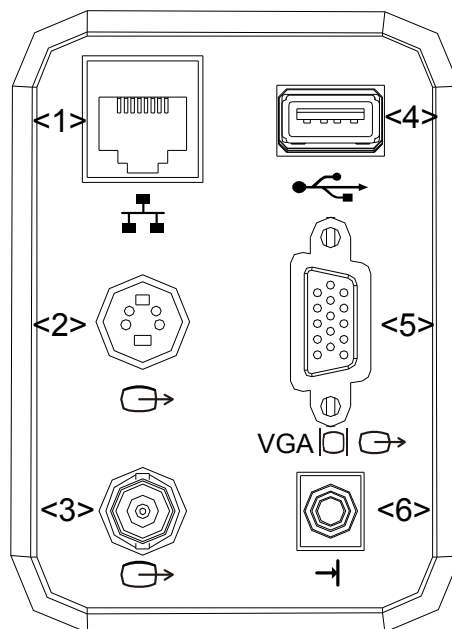

No.	Name	Function
1	Network port	To connect the network cable
2	S-Video output	Separate video output, connecting video printer or monitor
3	Video output (coaxial-cable)	Video output, connecting video printer or monitor
4	USB ports	Used to connect USB devices.
5	VGA output	VGA signal output
6	Video printing control	Connects the remote cable of the video printer.

### 1.4.3 Power Supply Panel

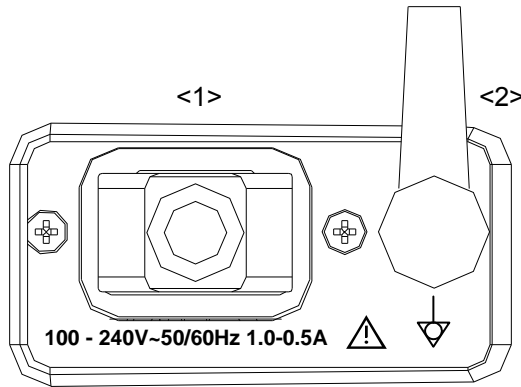

No.	Name	Function
1.	Power inlet	AC power inlet
2.	Equipotential terminal	Used for equipotential connection, that balances the protective earth potentials between the system and other electrical equipment.

## 1.4.4 Control Panel

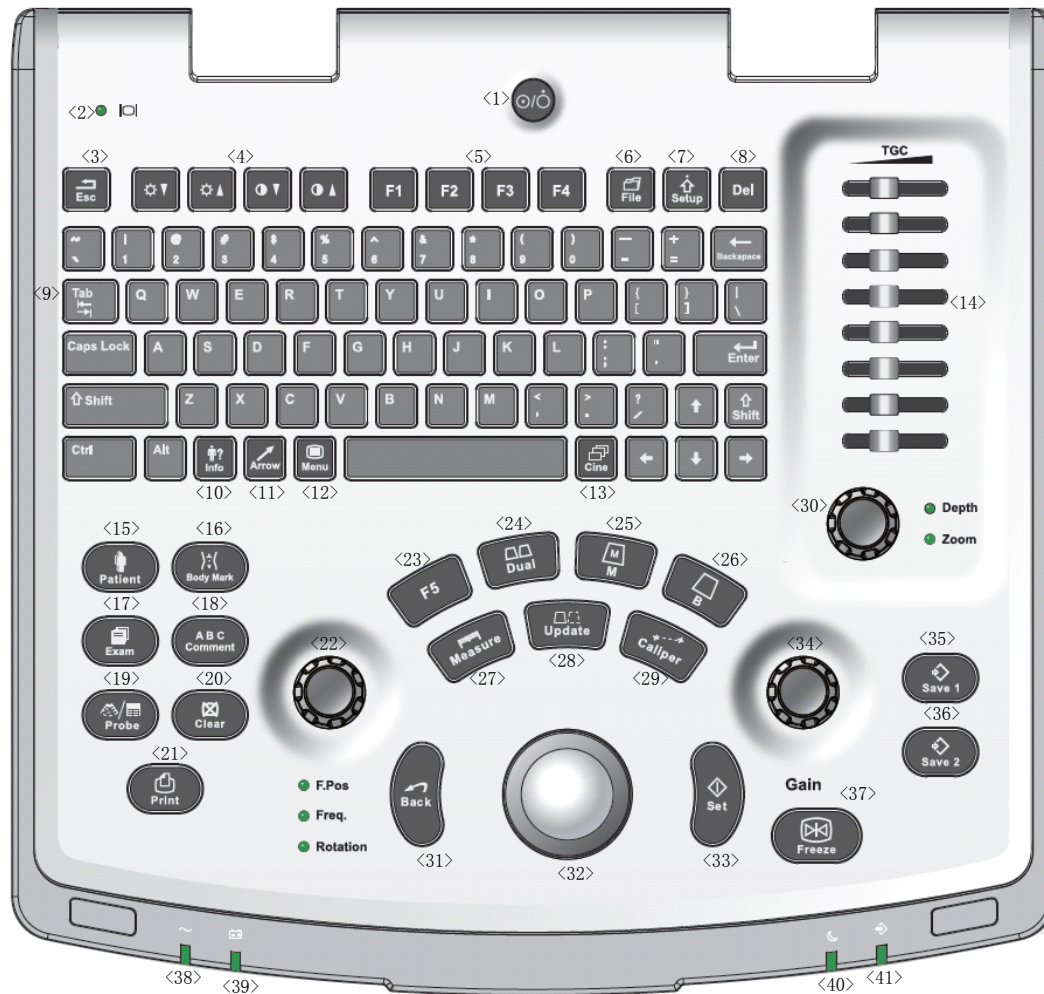













No.	Name	Description	Function
1	/	Power button	Power button Press to turn on/off the system
2	/	Monitor status indicator	Green: working in normal status; Orange: no signal.
3	Esc	Exit	Press to exit the current status to the previous status.
4	/	Direction key	To adjust monitor brightness or contrast when pressing with <Fn> key.
5	F1~F4	User-defined key	You can assign a function to the key.
6	File	File	To enter/exit file system (iStation)
7	Setup	Setting	To open/close the Setup menu.
8	Del	/	Press to delete the comment, etc.
9	/	Alphanumeric keys	Same as on PC

No.	Name	Description	Function
10	Info	Patient Info	To open/ exit patient information screen.
11	Arrow	Arrow	Press to enter or exit the arrow comment status.
12	Menu	Main menu	Press to display or hide a mode-specific parameter menu.
13	Cine	Cine Review	Press to enter/ exit the Cine Review status.
14	TGC	/	TGC slider, to adjust the depth gain.
15	Patient	End Exam	To end the current exam.
16	Body Mark	Body Mark	To enter/ exit the Body Mark status.
17	Exam	/	To select and start an exam.
18	Comment	Comments	Press to enter/ exit the character comment status.
19	Probe	Transducer switch	Press to switch Probe and Exam Type
20	Clear	/	Press to clear the comments or measurement calipers on the screen.
21	Print	/	Press to print: user-defined key.
22	F.Pos Freq Rotation	Focus Position Frequency Rotation	Press: switch between F.Pos and Freq Rotate: adjust rotation angle
23	F5	User-defined key	You can assign a function to the key.
24	Dual	Dual-split screen	To enter Dual mode in Non-Dual mode; Switch between windows in Dual mode
25	M	/	Press to enter the M mode.
26	B	/	Press to enter the B mode
27	Measure	/	Press to enter/Exit Measurement
28	Update	/	Measurement status: press to switch between the fixed and active end of the caliper; Multi-imaging mode: press to change the currently active window.
29	Caliper	/	Press to enter/exit Measurement
30	Depth Zoom	/	Press: to switch between Depth and Zoom; Rotate: to adjust corresponding parameter
31	Back	/	Press to decrease parameter value or undo last step during measurement
32	/	Trackball	Roll the trackball to change the cursor position.
33	Set	/	Used in selection.
34	Gain	/	To adjust B or M gain
35	Freeze	/	Press to freeze or unfreeze the image.
36	Save 1	/	Press to save, user-defined key









No.	Name	Description	Function
37	Save 2	/	Press to save, user-defined key
38	/	Indicator 1	AC indicator AC supply: light green; Battery supply: light off.
39	/	Indicator 2	Battery status indicator Charging: orange Full: green Discharging (electricity >20%): green Discharging (electricity <20%): blinking in orange Discharging (electricity <5%): blinking in orange rapidly Non-charge/ discharge: light off
40	/	Indicator 3	Reserved
41	/	Indicator 4	Reserved

## 1.4.5 Symbols

This system uses the symbols listed in the following table, and their meanings are explained as well.

Symbol	Description
	Type-BF applied part
	General warning, caution, risk of danger
	Dangerous voltage
	Equipotentiality
	Power button
	Serial number
	AC (Alternating current)
	Battery Status Indicator
	Standby indicator
	Hard disk indicator
	Brightness of the display
	Contrast of the display
	Video out



Symbol	Description
	Remote control port
<b>VGA</b> 	VGA out
	USB port
	Network port
	Transducer socket A
	Transducer socket B
	Date of manufacture
	Authorized representative in the European Community.
	This product is provided with a CE marking in accordance with the regulations stated in Council Directive 93 / 42 / EEC concerning Medical Devices. The number adjacent to the CE marking (0123) is the number of the EU-notified body certified for meeting the requirements of the Directive.



# 2 Preparing the System

---

This chapter introduces how to prepare and get familiar with the system.

## 2.1 Setup and Connections

### 2.1.1 Moving and Placing the System

Please read and understand the safety precautions before moving and placing the system.

1. Turn off the power and disconnect the peripheral devices.
2. Move the system to the desired position by holding the handle.
3. Leave at least 20cm clearance at the back and two sides of the machine.

<b>⚠ CAUTION:</b> Ensure enough clearance at the back and both side of the machine, otherwise failure may happen because of the increasing temperature inside the machine.
--

### 2.1.2 Connecting the Power Cord

- Connecting the power cord

<b>⚠ WARNING:</b>	<ol style="list-style-type: none"><li>1. Do not connect this system to outlets with the same circuit breakers and fuses that control current to devices such as life-support systems. If this system malfunctions and generates an overcurrent, or when there is an instantaneous current at power ON, the circuit breakers and fuses of the building's supply circuit may be tripped.</li><li>2. Do not connect the three-wire power cable of the machine to a two-wire plug without grounding protection phase, otherwise electric shock may happen.</li><li>3. Use the power input cord as the power breaking facility of the system.</li></ol>
-------------------	--

1. Ensure that the external power supply system meets the requirements and the power switch of the system is turned off.
2. Attach the connector of the power cord to the system.
3. Insert the power plug securely into the wall outlet.

## 2.1.3 Connecting/Disconnecting the Transducers

- ⚠ CAUTION:**
1. Connect/disconnect the transducer only after the system power is turned off or the image is frozen (by Freeze key), otherwise failure may happen.
  2. When connecting/disconnecting the transducer, place the transducer on the corresponding transducer holder and hook the transducer cable on the cable hanger to avoid accidental falling of the transducer, which may damage the transducer.

**NOTE:** Use the transducer provided by Mindray only. Otherwise may damage the system and transducer or cause a fire.

### ■ Connecting the transducer

**⚠ WARNING:** Prior to connecting the transducer, the user should ensure that the transducer, cable and the connector are all in good condition (no rift or fall-off). Electric shock may happen if using any abnormal transducer.

1. Turn off the ultrasonic system or freeze the image.
2. Check whether the lock of the transducer connector is released. If not, turn the lock counter-clockwise to release it.
3. Keep the cable backwards and insert the transducer connector straight into the socket.
4. Turn the lock clockwise to lock the transducer connector.
5. Hang the transducer cable to the hook for transducer cable.

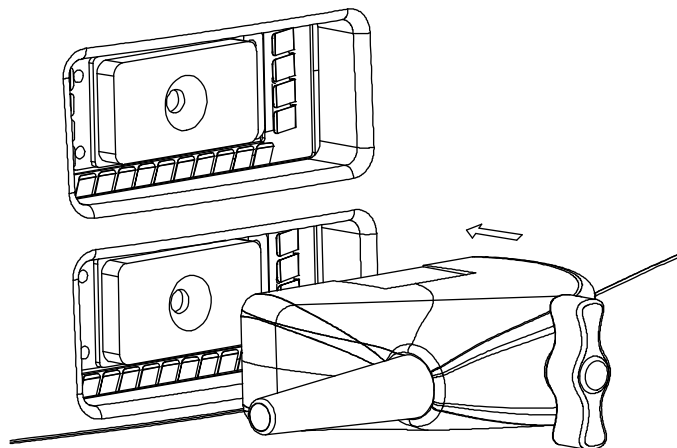

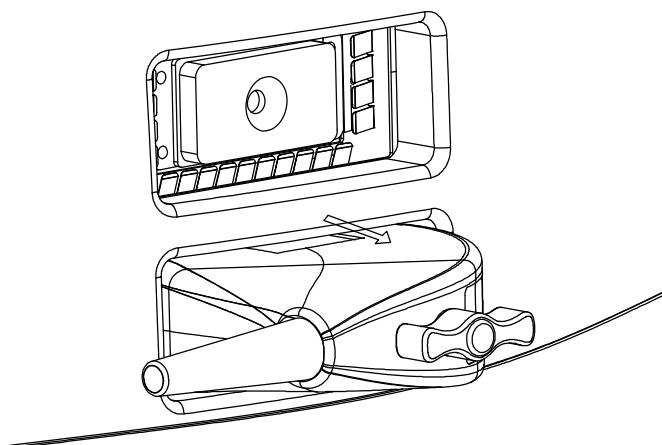

### ■ Disconnecting the transducer

1. Turn off the system or freeze the image.
2. Turn the lock of the transducer connector counter-clockwise to release the connector.
3. Pull the transducer connector straight out vertically.
4. Settle the transducer appropriately.



## 2.1.4 Connecting/Disconnecting USB device

**⚠ WARNING:** DO NOT directly remove a USB memory device; otherwise the USB memory device and / or the system may be damaged.

- Connecting: When connecting a USB memory device to the system via a USB port, the system recognizes the device automatically and a “” mark appears in the lower, right-hand corner of the screen.
- Disconnecting:
  1. Move cursor to the “” mark and press <Set>. A dialog box pops up.
  2. Select the device to disconnect and click [Ok]. The “” mark disappears and you can remove the USB device securely.

## 2.1.5 Connecting a Footswitch

Plug the connector of the footswitch to the socket with the bulge of the footswitch connector aligning with the groove of the socket.

## 2.1.6 Connecting a Printer

Refer to the manual of the printer for details.

- Graph/Text Printer
  1. Connect the graph/text printer and the ultrasonic system with a USB cable.
  2. After the connection, the system identifies the printer automatically.
- Video Printer
  1. Turn off the ultrasonic system and the video printer.
  2. Connect the input port of the video printer and the output of the ultrasonic system with the data cable (S-Video or coaxial cable).
  3. To print with the <Print> key or the footswitch, please connect the “REMOTE” port of the video printer and the “REMOTE” port of the ultrasonic system with the remote cable.
  4. Connect the power cord of the video printer.
  5. Turn on the ultrasonic system and the video printer.

## 2.1.7 Connecting an External Display

1. Turn off the ultrasonic system and the external display.
2. Connect the VGA out of the ultrasonic system and the VGA input of the external display.
3. Turn on the ultrasonic system and the external display.

## 2.1.8 Using the Mobile Power

**NOTE:** When using the ultrasonic system with the mobile power, make sure the environment meets the requirements of the ultrasonic system.

For details about the operations, please refer to the operator's manual of the mobile power.

## 2.2 Powering ON/OFF

**⚠WARNING:** To ensure safe and effective system operation, you must perform daily maintenance and checks. If the system begins to function improperly – immediately stop scanning. If the system continues to function improperly – fully shut down the system and contact Mindray Customer Service Department or sales representative. If you use the system in a persistent improperly functioning state – you may harm the patient or damage the equipment.

### 2.2.1 Checking before Powering ON

Please check whether the system and the environment meet the requirements below before powering on the system.

No.	Items	Result
1	The temperature, relative humidity and atmospheric pressure shall meet the requirements of operating conditions.	
2	There shall be no condensation.	
3	There shall be no distortion, damage or dirt on the system and peripheral devices. If any dirt is found, cleaning shall be performed as defined in section "11 Cleaning and Maintaining the System".	
4	There shall be no loose screws on the monitor or control panel.	
5	There shall be no cable damage (e.g. power cord). Maintaining secure connections to the system at all times.	
6	The transducers and transducer cables shall be free of damage or stains. See the transducer operator's manuals for transducer cleaning and disinfection.	
7	No miscellaneous odds and ends are allowed to be attached or affixed to the control panel.	
8	Check the power cord / power supply and all I / O ports. Ensure that all connections are free from damage and remain clear of foreign object blockages. There shall be no obstacles around the system and its air vent.	

No.	Items	Result
9	Prior to each use of a transducer, you should perform transducer cleaning and disinfection as per the transducer operator's manual.	
10	The overall scanning environment and field must be clean.	

## 2.2.2 Powering ON

**⚠WARNING:** If you use a transducer giving off excessive heat, it may burn the patient.

**NOTE:** When you start the system or switch between transducers, you will hear clicking sounds – this is expected behavior.

Press the power switch at the back of the system to power on the system.

Check whether the system starts normally and check the system after powering on.

No.	Items	Result
1	There shall no unusual sounds or smells indicating possible overheating.	
2	There shall be no persistently displayed system error message.	
3	There shall no evident excessive noise, discontinuous, absent or black artifacts in the B Mode image.	
4	Check if there is abnormal heat on the surface of the transducer during an ultrasound procedure.	
5	The exam date and time are the same as the system date and time, and are displayed correctly.	

**⚠CAUTION:** If the system time is not the same as the current time, misdiagnose may occur.

## 2.2.3 Restarting

When any of the following abnormalities occurs with the system, the system may be able to recover from the abnormality by power OFF/ON once again:

- An error message is displayed and does not disappear.
- The screen display is abnormal.
- The system operations are disabled.
- Restart the system to put the new software into effect.

## 2.2.4 Powering OFF

If you are not using the system for a long time, please shut down the system:

1. Put the transducer away.
2. Press the power switch to shut down the system.
3. Turn off all peripherals connected to the system.

## 2.3 Main Interface

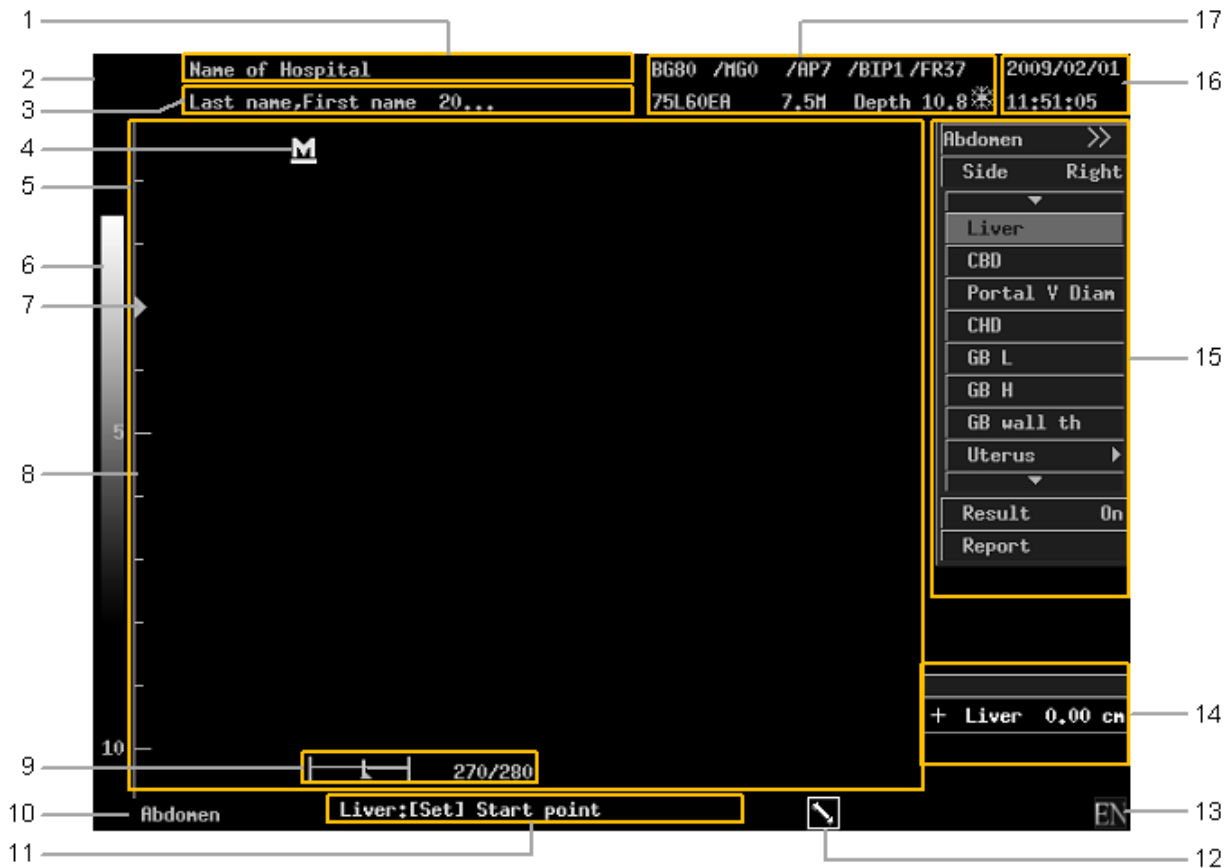

The main interface is as above, and the functions of areas are listed below:

No.	Description
1	Name of hospital, which can be preset.
2	Logo of the manufacturer
3	Patient information and the operator.
4	Mark of start scanning side, by which you can identify the direction of the image.
5	Image zone
6	Grey scale bar
7	Mark of focus
8	Depth scale
9	Cine progress bar
10	Current exam mode
11	Prompt information
12	Mark of current mode
13	Current input method



No.	Description
14	Result window of measuring mode
15	Menu zone
16	Date and time
17	Image parameters, type of transducer, transmitting frequency and depth.  is the frozen mark, which is displayed when frozen.

## 2.4 Basic Operations

■ To move a Dialog Box

1. Move the cursor to the title of the dialog box, and the cursor turns to “”.
2. Press <Set> and the cursor turns to the frame of the dialog box.
3. Roll the track ball to locate the frame of the dialog box to the anticipated area.
4. Press <Set> to confirm moving the dialog box or press <Back> to cancel.



# 3 Beginning an Exam

---

This chapter introduces the basic procedures and operations of an ultrasonic exam.

## 3.1 Entering Patient Information

Although you can start scanning a patient without entering patient information, it is recommended to enter patient information before an examination is started.

**⚠ CAUTION:** Before examining a new patient, press the <Patient> key to end the exam of the previous patient, update the patient ID and information, to avoid mixing data of the next new patient.

- To open the “Patient Info” dialog box:
  - Press <Info> to open the “Patient Info” dialog box.
  - Click the patient information area in the left top corner of the screen to open the “Patient Info” dialog box.
- To close the “Patient Info” dialog box:

In the “Patient Info” dialog box,

  - Click [Ok] or press <Info> again to save the patient information and close the “Patient Info” dialog box.
  - Click [Cancel] or press <Esc> to cancel and close the “Patient Info” dialog box.
- To enter the basic information of the patient:
  - Patient ID: Input the patient ID with the keyboard. The patient ID cannot be empty. Once the patient ID is input and conformed, it cannot be modified. The patient IDs of different patients cannot be the same as each other. If ID that already exists is input, the system will prompt whether you want to load the patient information.
  - Last Name/First Name: Input the name with keyboard.
  - DOB (Date of Birth) and age:
    - Input the birthday in the text box manually. Or
    - Click the “” icon to open the date box and select the date. After the birthday is input, the system calculates the age automatically.
  - Gender: Select the gender in the drop-down list.
- Information related to exam: Click the label below the basic information to switch to the corresponding page and input information related to exam.

## 3.2 Getting Patient Information

### 3.2.1 iStation

iStation is used to query patient information, in which the DICOM functions are only available for systems configured with DICOM software.

- To enter iStation:
  - Press <Info> to open the “Patient Info” dialog box, and then click [iStation] to open the “iStation”.
  - Press <File> to open the “iStation”.
- To query:
  1. Selecting the data source: Select the data source in the “Data Source” drop-down list.
  2. Input the query condition:
    - Input the query condition in the text box on the right-hand of the corresponding keywords.
    - Select the date range in the controls behind the
  3. Click [Query] and the results are displayed in the result list.
- Exam Operation

In the list of results,

  - [Info]: Select a record, and click [Info] to check the patient information.
  - [Report]: Select a record with exam data, and click [Report] to check the exam report.
  - [Delete]: To delete the selected records. To select plural patients, press <Ctrl> or <Shift> when selecting.
  - [Backup]: To backup the selected records to external storage devices when there are external storage devices connected.
  - [Restore]:
    1. Select an external storage device with backup data in the drop-down list below “Data Source”. The data are listed in the record list.
    2. Select the records to be restored, and click [Restore] to restore them to the ultrasonic system. If the records already exist, the system will prompt whether to overwrite them or not. Select the appropriate option according to your requirements.
  - [Select All]: To select all the records.
  - [Send To]: To send the selected records to external storage devices.
  - [DICOM Storage]: Save the DICOM files of the selected record to the preset DICOM storage server.
  - [DICOM Print]: Print the single frame DICOM files of the selected report with the preset DICOM printer.
  - Select a record within 24 hours, and click [Activate Exam] to activate the exam.
- Image Operation

Select an exam, and the images included are listed in the file list below the record list. Select an image,

  - [Open]: To open the selected image.
  - [Delete]: To delete the selected images.
  - [Send To]: To send the selected images to external storage devices.
  - [DICOM Storage]: Save the DICOM image to preset DICOM storage server.
  - [DICOM Print]: Print the single frame DICOM image with the preset DICOM printer.

## 3.2.2 Work List

Work List is used to get patient information from the work list server. It is only available for systems configured with DICOM software.

- To open the “Work List” dialog box:
  1. Press <Info> to open the “Patient Info” dialog box,
  2. Click [Work List] in the “Patient Info” dialog box to open the “Work List” dialog box.
- To query
  1. Input the query conditions.
    - Select the work list server.
    - Select the date of exam: Input the birthday in the text box manually or click the “” icon to open the date box and select the date.
    - Input the query conditions.
  2. Click [Query], and the results are listed in the list box below. Click [Clear] to clear the query conditions.
  3. Select a patient, and click the buttons below the list to:
    - [Start Exam]: To import the patient information to system and start an exam.
    - [Transfer]: To read the patient information to “Patient Info” dialog box. You can edit the information except the ID, and then click [OK] to start an exam.
    - [Show Detail]: To check the detailed information of the patient.
    - [Return]: To exit Work List.

## 3.3 Selecting the Exam Mode



 **CAUTION:** Once the exam mode is changed during a measurement, all the calipers and measurement data will be cleared from the screen.

- To select an exam mode

After powering on, the system selects the preset exam mode automatically. If you want to switch to other exam modes, press <Exam> to open the exam mode menu and select an exam mode.
- To switch transducers: If two transducers are connected, press <Probe> to switch transducers.

## 3.4 Selecting the Image Mode

The image modes provided are as follows:

- B Mode: Press <B> to enter B Mode.
  - Dual B Mode: Press <Dual> to enter dual B Mode
  - Quad B Mode: Press User-defined key to enter quad B Mode, and then press the key again to add a new image window or switch among the image windows. Refer to “9.2.6 Key Config” for how to preset the user-defined key to enter quad mode.
  - In dual B or quad B mode, the  mark can be used to identify the active window: If the  mark is white, the corresponding window is active; if the mark  is grey, the corresponding window is inactive.
- M Mode
  - M+B mode: Press <M> to enter M+B mode. In M+B mode, roll the trackball to adjust the sample line.

- M mode: After setting the sample line, press <M> again to enter M mode.

## 3.5 Adjusting the Image

### 3.5.1 Zooming

This system provides a zoom range of 100%~1000%.

1. Press the multifunctional knob of <Depth/Zoom> until the indicator corresponding to “Zoom” is lit up. A viewfinder is displayed in the image window.
2. Move the viewfinder with the trackball to select the region to be magnified.
3. Rotate the Multifunctional Knob to change the magnification ratio, and the viewfinder changes correspondingly. Rotate the multifunctional knob clockwise to increase the magnification ratio and the viewfinder enlarges; rotate the multifunctional knob anticlockwise to decrease the magnification ratio and the viewfinder shrinks.
4. Press <Set> and the viewfinder disappears. The magnified image is displayed. At this moment,
  - Roll the track ball to pan through the image.
  - Rotate <Multifunctional Knob> to change the magnification ratio.
5. Press <Multifunctional Knob> again to exit zoom status, and the indicator corresponding to “Zoom” goes out.

### 3.5.2 Zooming with Thumbnail

To use zooming with thumbnail, enable “Display Thumbnail when Zoom” in preset first. Refer to “9.2.3 Image Preset” for details.

1. Press the multifunctional knob of <Depth/Zoom> until the indicator corresponding to “Zoom” is lit up. A thumbnail appears in the lower, right corner of the screen.
2. Move the viewfinder in the thumbnail with the trackball to select the region to be magnified.
3. Rotate the <Multifunctional Knob> to change the magnification ratio, and the viewfinder changes correspondingly. Rotate the multifunctional knob clockwise to increase the magnification ratio and the viewfinder enlarges; rotate the multifunctional knob anticlockwise to decrease the magnification ratio and the viewfinder shrinks.
4. Press the <Multifunctional Knob> again to exit zooming status, and the indicator corresponding to “Zoom” goes out.

### 3.5.3 Rotating and Flipping the Image

#### ■ Rotating the Image

1. Check whether the menu corresponding to the current mode is open. If not, press <Menu> to open it.
2. Move cursor to [Rotation (Angle)]. Then press <Set> to rotate the image clockwise 90 degrees, or press <Back> to rotate the image anticlockwise 90 degrees.

#### ■ Flipping the Image: Images of B mode can be flipped horizontally and vertically.

1. Check whether the menu corresponding to the current mode is open. If not, press <Menu> to open it.
2. Move the cursor to [L/R Flip] and press <Set> to invert the image horizontally.
3. Move the cursor to [U/D Flip] and press <Set> to invert the image vertically.

- Conforming the Direction of the Image

The  mark in the image window is corresponding with the bulge on the transducer head (for some transducers, it may be a groove) and it is intended for helping to identify the direction of the image. When the image is rotated or flipped, the location of this mark changes as well.

### 3.5.4 Image Merge

In dual B mode, if “Image Merge” is already enabled in “Preset→System Preset→Image Preset”, the current transducer is linear transducer, and the depth of two image windows are the same, the system will put the two images together to extend your field of vision.

## 3.6 Cine Review

During the exam, press <Freeze> to freeze the image and you can review the images prior to the image frozen.

The process bars of cine review are as follows:

- B mode

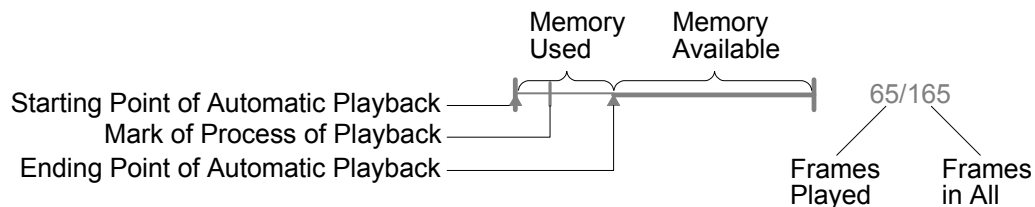

- M mode

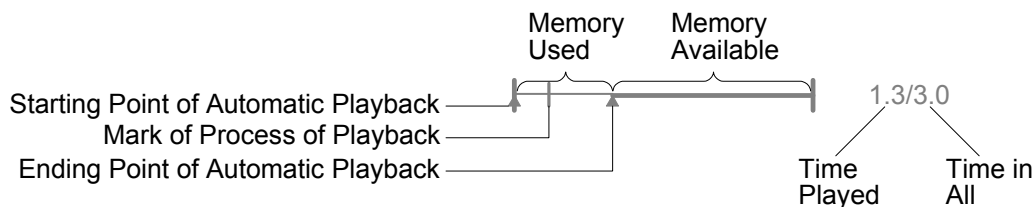

### 3.6.1 Cine Review of B Mode

In the following conditions, the cine review memory will be cleared:

- Beginning a new exam
- Switching transducers (only the corresponding part is cleared in Dual B or Quad B mode)
- Switching among image modes
- Adjustment of some real-time image parameters (such as depth)
- Unfreezing

- Manual Review

Manual review is the default review mode. During an exam, press <Freeze> to freeze the image and start reviewing. The freezing mark appears in the upper, right corner of the screen. Here,

- Press <Menu> to open/close the Freeze Menu.
- Roll the track ball to review manually: Roll it left to review earlier images and roll it right to review later images.

- **Reviewing All**
  1. In manual review mode, press <Cine> to release the cursor.
  2. Press <Menu> to open the Freeze Menu. Then click [Review/Stop] to start reviewing, and click [Review/Stop] again to stop reviewing.
  3. To select the reviewing speed: Move cursor to [Speed (value)], and then press <Set> to increase the reviewing speed, or press <Back> to decrease the reviewing speed.
- **Reviewing a Specified Segment**
  1. To set the start point:
    - (1) Review to the start point in manual mode.
    - (2) Press <Set> to set the start point.
  2. To set the end point:
    - (1) Review to the end point in manual mode.
    - (2) Press <Update> to activate the mark of the end point and the mark turns to white.
    - (3) Press <Set> to set the end point.
  3. To adjust the start point and end point:
    - (1) Press <Update> to switch between the two marks. The activated mark is white and the inactivated mark is grey.
    - (2) Press <Set> to set the activated mark: the left mark will be set as start point and the right point will be set as end point.
  4. Press <Menu> to open the “Freeze Menu” or press <Cine> to release the cursor. Click [Review/Stop] to start auto playback.
  5. To select the reviewing speed: Move cursor to [Speed (value)], and then press <Set> to increase the reviewing speed, or press <Back> to decrease the reviewing speed.
  6. Click [Review/Stop] again to stop.
- **To Save an Image:**

Press <Menu> to open the Freeze Menu. In the Freeze Menu, move the cursor to [Save As...] and click a format in the sub menu to save image or cine files to USB storage device.

### 3.6.2 Cine Review of 2B/4B Mode

In Dual B/Quad B mode, the cine memory is split into 2/4 correspondingly. The basic operations are the same as those in B mode, press <Dual>/User-defined quad key to activate an image window and review.

### 3.6.3 Cine Review of M/M+B Mode

- **Manual review**
  - Roll the trackball left to review earlier M images.
  - Roll the trackball right to review later M images.
  - Press <M> to switch between M+B review/M review.



## 3.7 Brief Introductions to Measurement

- ⚠ WARNING:**
1. Be sure to measure areas of interest from the most optimal image plane to avoid misdiagnosis from inaccurate measurement values.
  2. If Image Merge is activated, the results of measurements over two image windows are influenced by plural factors and they are for reference only.

- ⚠ CAUTION:**
1. If an image is unfrozen or the mode is changed during a measurement, the calipers and measurement data will be cleared from the screen. The general measurement data will be lost (the application measurement data are stored in the report).
  2. If the system is turned off or [End Exam] is selected during a measurement, the data not saved will be lost.

### 3.7.1 Basic Operations and Buttons

The title bar of the measurement menu is the name of the current measurement package. If there are more than one available measurement packages of the current exam mode, click the title bar to switch to other packages.

#### Basic Buttons

- <Measure>: Enters/exits measurement mode.
- <Menu>: Opens/closes the measurement menu.
- <Set>:
  - Select an item in the measurement menu, then press <Set> to activate the measurement.
  - During a measurement, press <Set> to confirm the current operation and continue.
- <Update>:
  - To switch among items: After activating an item and before start measuring, press <Update> to switch among the available items.
  - To switch between ends: During a measurement, press <Update> to switch between the fixed end and the active end.
- <Back>:
  - During a measurement, press <Back> to cancel the last operation.
  - Press <Back> continually to delete completed measurements in backward sequence.

### 3.7.2 Measurement Items

The measurement library of this system provides Measurement, Calculate and Study items of General, Abdomen, Gynecology, Cardiac, Vascular, Urology, SmallPart, ORTH and Obstetric. You can select appropriate items to create measurement packages.

The items of general measurement are listed below. For detailed information about application measurements, please refer to [Advanced Volume].

Mode	Type	Item	Descriptions
2D	Measurement	Distance	Measures the distance between two points of interest.
		Area	Measures the area and perimeter of a closed region.
		Angle	Measures the angle between two intersected planes.
		Cross	Measures the length of two line segments, which are perpendicular to each other.
		TLength	Measures the length of a curve.
		Parallel	Measures the distances between each pair of parallel lines in a sequence.
		B-Profile	Counts the grayscale distribution of ultrasonic echo signals across a line.
		B-Hist	Counts the grayscale distribution of ultrasonic echo signals in a closed region.
		Depth	Measures the depth of a spot.
	Calculate	Ratio (D)	Measures the lengths of any two lines and calculates the ratio.
		Volume	Calculates the volume of a region.
		Ratio (A)	Measures the areas of any two regions and the calculated ratio.
	Study	/	
M	Measurement	Heart Rate	Measures the time of n ( $n \leq 8$ ) cardiac cycles and calculates the heart rate in M mode image.
		Slope	Measures the distance and time between two points and calculates the slope.
		Distance	Measures the distance between two points of interest.
		Time	Measures the time interval between two points.
		Velocity	Calculates the average velocity by measuring the distance and time between two points.
	Calculate	/	
	Study	/	

# 4 Optimizing the Image

This chapter introduces how to optimizing the image by adjusting the image parameters.

Before optimizing the image by adjusting the image parameters, use the brightness and contrast knob to adjust the monitor to the best functional mode.

The image parameters area is as follows:

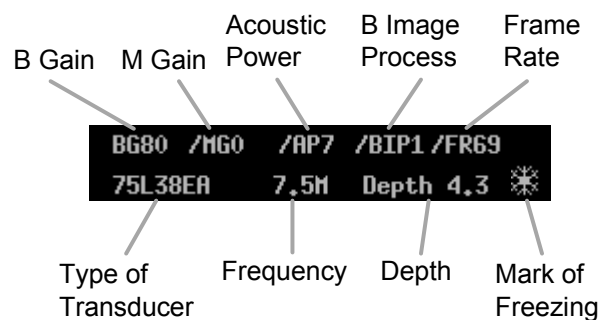

## 4.1 Basic Operations

Objectives	Available Operations
To increase the brightness.	Increase the gain. Increase the acoustic power (do try to adjust gain first before increasing acoustic power).
To make the brightness distribute uniformly.	Adjust TGC (Time Gain Compensation).
To enhance the contrast.	Decrease the Dyn Rng (Dynamic Range).
To observe deeper objectives.	Increase the depth.
To observe shallower objectives.	Decrease the depth.
To increase the frame rate.	Decrease the angle. Decrease the depth. Decrease the number of focuses. Select "Hi Frm Rate" in "Scan Mode".

## 4.2 B Mode

### 4.2.1 Depth

<b>Description</b>	Adjusts the image depth. Depth is available for B/M modes.
<b>Operations</b>	<p>Depth and Zoom share the same &lt;Multifunctional Knob&gt; (right). Press the &lt;Multifunctional Knob&gt; to switch among the items and then rotate the knob to adjust the item when the corresponding indicator is lit up.</p> <p>The knob is in Depth mode by default. If not, press the knob continually until the indicator corresponding to “Depth” is lit up, then rotate the knob to adjust the depth.</p> <p>The depth range varies depending on the transducer.</p>
<b>Effects</b>	Increase the depth, and you can see tissue in deeper locations; decrease the depth, and you can see tissue in shallower locations.
<b>Impacts</b>	<p>Depth is in negative correlation with the frame rate: the larger the depth, the lower the frame rate.</p> <p>Changing depth will clear the cine memory.</p>
<b>Operation Conflicts</b>	The image depth cannot be adjusted when the image is frozen.

### 4.2.2 Frequency

<b>Description</b>	Adjusts the transducer transmitting frequency.
<b>Operations</b>	<p>Focus position (F.Pos.), frequency (Freq.) and Rotation share the same &lt;Multifunctional Knob&gt; (left). Press the knob to switch among the items and rotate the knob to adjust the item when the corresponding indicator is lit up.</p> <p>Press the &lt;Multifunctional Knob&gt; until the indicator corresponding to “Freq.” is lit up, and then rotate the knob to adjust the frequency.</p> <p>The current transmitting frequency is displayed in the image parameter area.</p>
<b>Effects</b>	<p>The higher the frequency, the better the axial resolution, and the worse the force of penetration. The lower the frequency, the worse the axial resolution, and the better the force of penetration.</p> <p>For transducers that support harmonic, using harmonic (there is an “H” before the frequency) will increase the contrast of the image.</p>
<b>Impacts</b>	Changing frequency will clear the cine memory.
<b>Operation Conflicts</b>	The transmitting frequency cannot be adjusted when the image is frozen.

### 4.2.3 Gain

<b>Description</b>	B/M gain is intended to adjust the gain of the whole receiving system and the signal sensitivity of B/M image. The adjusting range is 0dB~100dB. B-mode and M-mode Gains are displayed in the Parameter Area on the top of the screen.
<b>Operations</b>	Rotate <Gain> to adjust the gain of B image and M image. The gain of M image can also be adjusted separately in M+B mode by using the [M Gain] in the M image menu.
<b>Effects</b>	Increasing the gain will brighten the image and you can see more received signals. However, noises can also be increased.
<b>Impacts</b>	The adjustment to gain will influence the cine review.
<b>Operation Conflicts</b>	The gain cannot be adjusted when the image is frozen.

### 4.2.4 Acoustic Power

<b>Description</b>	Acoustic power is the transmitting power of ultrasonic wave. You should choose the acoustic power according to "12 Acoustic Output".
<b>Operations</b>	Before adjusting acoustic power, please try to adjust other parameters (such as gain) first. Press <Menu> to show the image menu, and select [A.Power], use <Set> and <Back> to increase and decrease the value. The current value of acoustic power is displayed in the image parameter area.
<b>Effects</b>	Changing the acoustic power will influence the brightness and contrast of the image and the force of penetration: Generally, increasing the acoustic power will increase the brightness and contrast of the image and the force of penetration and vice versa.
<b>Impacts</b>	The adjustment to acoustic power will influence the cine review.
<b>Operation Conflicts</b>	The acoustic power cannot be adjusted when the image is frozen.

### 4.2.5 TGC

<b>Description</b>	Ultrasonic wave attenuates when transmitting inside tissue, so the received signals of deeper tissue are weaker than those of superficial tissue. The system compensates the signals from deeper tissue by segments to make the image of deeper issue clear. Adjusting TGC (Time Gain Compensation) will amend the compensation.
<b>Operations</b>	Slide the TGC sliders on the control panel to adjust the corresponding TGC. When toggling TGC slider, the TGC curve is displayed on the left of the screen and changes with the movement of the slider. About 1.5s after the adjustment is finished, the TGC curve disappears.

<b>Effects</b>	Slide the TGC slider right to increase the compensation to this segment and the corresponding area gets brighter. Slide the TGC slider left to decrease the compensation to this segment and the corresponding area gets darker.
<b>Impacts</b>	The adjustment to TGC will influence the cine review.
<b>Operation Conflicts</b>	When the image is frozen, the adjustment to TGC is unavailable temporarily and it takes effect after the image is defroze.

## 4.2.6 Focus

### ■ Number of focuses

<b>Description</b>	Changes the number of focuses.
<b>Operations</b>	Press <Menu> to open B Img Menu, and move cursor to [Focus Number (num)]. Press <Set> to increase the number of focuses and press <Back> to decrease the number of focuses. The “▶” mark in the depth scale shows a focus.
<b>Effects</b>	/
<b>Impacts</b>	Increasing number of focuses will decrease the frame rate. Changing number of focuses will clear the cine memory.
<b>Operation Conflicts</b>	The number of focuses cannot be changed when the image is frozen.

### ■ Position of focuses

<b>Description</b>	Changes the position of focuses.
<b>Operations</b>	Focus position (F.Pos.), frequency (Freq.) and Rotation share the same <Multifunctional Knob> (left). Press the knob to switch among the items and rotate the knob to adjust the item when the corresponding indicator is lit up. Press the knob until the indicator corresponding to “F.Pos.” is lit up, and then rotate the knob to adjust the position of focuses. The “▶” mark in the depth scale shows the current position of the focuses.
<b>Effects</b>	/
<b>Impacts</b>	Changing position of focuses will clear the cine memory.
<b>Operation Conflicts</b>	The position of focuses cannot be changed when the image is frozen.

## 4.2.7 B/M Dyn Rng (Dynamic Range)

<b>Description</b>	Adjusts contrast resolution of the B Mode image to compress or expand the gray display range. The range is 30dB~100dB and the step is 5.
<b>Operations</b>	Press <Menu> to open B Img Menu, and move cursor to [Dyn Rng (value)]. Press <Set> to increase the dynamic range and press <Back> to decrease the dynamic range. The value is displayed in the menu.
<b>Effects</b>	The less the dynamic range, the higher the contrast. The more the dynamic range, the lower the contrast. The image displayed may fail to match the real one when the value of Dynamic Range is too great or too little. The recommended range is: 55~75.

**Impacts** The adjustment to Dynamic Range will influence the cine review.  
**Operation Conflicts** The Dynamic Range cannot be adjusted when the image is frozen.

## 4.2.8 **Img Enhance (Image Enhance)**

**Description** The range of image enhancement is 0~4. 0 represents no image enhancement and 4 represents maximum image enhancement.  
**Operations** Press <Menu> to open B Img Menu, and move cursor to [Img Enhance (value)]. Press <Set> to increase the image enhance and press <Back> to decrease the image enhance. The value is displayed in the menu.  
**Effects** /  
**Impacts** The adjustment to image enhance will influence the cine review.  
**Operation Conflicts** The image enhance cannot be adjusted when the image is frozen.

## 4.2.9 **Frame Avg (Frame Average)**

**Description** Averages adjacent B images to smooth the image. The range of frame average is 0~7.  
Frame Average is only available for B image.  
**Operations** Press <Menu> to open B Img Menu, and move cursor to [Frame Avg (value)]. Press <Set> to increase the frame average and press <Back> to decrease the frame average. The value is displayed in the menu.  
**Effects** Smooths the image.  
**Impacts** The adjustment to frame average will influence the cine review.  
**Operation Conflicts** The frame average cannot be adjusted when the image is frozen.

## 4.2.10 **TSI**

**Description** Optimizes the image for different tissue:

<b>Operations</b>	Press <Menu> to open B Img Menu, and move cursor to [TSI (value)]. Press <Set> or <Back> to adjust TSI.
	<ul style="list-style-type: none"> <li>■ General: It is helpful to scan the internal organs like liver, kidney, pancreas, thyroid, etc.</li> <li>■ Muscle: It is helpful to scan the muscle tissue or fibrous tissue, such as muscle, ligaments, tendon, etc.</li> <li>■ Fatty: It is helpful to scan tissue mainly composed of fat cell, such as lipoma, breast of old women.</li> <li>■ Fluid: It is helpful to scan tissue mainly consist of liquid, such as gallbladder, cyst, vessels, etc.</li> </ul>
<b>Effects</b>	/
<b>Impacts</b>	Adjusting TSI will clear the cine memory.
<b>Operation Conflicts</b>	The TSI cannot be changed when the image is frozen.

## 4.2.11 Scan Mode

### ■ Scanning Angle

<b>Description</b>	Adjusts the angle of scanning. It is available for B mode only, and the range is 0~3. 0 indicates the smallest scanning angle and 3 indicates the greatest scanning angle.
<b>Operations</b>	Press <Menu> to open B Img Menu, and move cursor to [Scan Mode]→[Scan Angle (value)]. Then press <Set> to increase the angle and press <Back> to decrease the angle.
<b>Effects</b>	The larger the scan angle, the wider your field of vision. The less the scan angle, the narrower your field of vision.
<b>Impacts</b>	Increasing the scanning angle will widen your field of vision while lowers the frame rate. Decreasing the scanning mode will narrow your field of vision while increases the frame rate.
<b>Operation Conflicts</b>	The scanning angle cannot be changed when the image is frozen.

### ■ Scanning Mode

<b>Description</b>	Changes the scanning mode.
<b>Operations</b>	Press <Menu> to open B Img Menu, and move cursor to [Scan Mode]→[Hi Density1/Hi Density2/Hi Frm Rate]. Then press <Set> or <Back> to select the scanning mode.
<b>Effects</b>	Select “Hi Density1/Hi Density2” to present clearer image and select “Hi Frm Rate” to acquire higher frame rate. “Hi Frm Rate” sacrifices image quality to acquire higher frame rate.
<b>Impacts</b>	Changing scanning mode will clear the cine memory.
<b>Operation Conflicts</b>	The scanning mode cannot be changed when the image is frozen.



## 4.2.12 IP

<b>Description</b>	IP is the combination of “Dyn Rng (Dynamic Range)”, “Image Enhance” and “Frame Avg (Frame Average)”. The parameters can be configured separately.
<b>Operations</b>	Press <Menu> to open the image menu, move the cursor to [IP], press <Set> or <Back> to adjust the value.
<b>Effects</b>	The effect is relative with the parameters.
<b>Impacts</b>	The adjustment to IP will influence the cine review.
<b>Operation Conflicts</b>	IP cannot be adjusted when the image is frozen.

## 4.2.13 B/M Post Process

### ■ Map

<b>Description</b>	“Effect” of post process is the combination of “Grey Curve”, “Grey Rejection” and “γ”. The system provides 8 effects, the parameters of which can be preset.
<b>Operations</b>	Press <Menu> to open B Img Menu, and move cursor to [Post Process]→[Effect (value)]. Then press <Set> or <Back> to select the effect.
<b>Effects</b>	Depends on the preset parameters.
<b>Impacts</b>	The adjustment to “Effect” will not influence the cine review.
<b>Operation Conflicts</b>	Effect can be adjusted when the image is frozen.

### ■ Curve

<b>Description</b>	“Grey Curve” is used to enhance or reject signals of corresponding segment.
<b>Operations</b>	<ol style="list-style-type: none"><li>1. Click [Post Process]→[Grey Curve] of B or M image menu to open the “Grey Curve” dialog box.</li><li>2. Move cursor to one of the nodes “ • ” and the cursor turns to “↕”. Press &lt;Set&gt;, and then move the node “ • ” to adjust the grey curve with the track ball. The image changes with the curve.</li><li>3. At this moment,<ul style="list-style-type: none"><li>● Press &lt;Set&gt; again to confirm moving the node “ • ” and the cursor turns back to “↕”. Repeat the procedures to adjust the next node, or</li><li>● Press &lt;Back&gt; to cancel moving the node “ • ” and the node restores to the original position.</li><li>● Click [Linear] to reset the grey curve.</li></ul></li><li>4. After the adjustment, click [OK] to confirm and exit or click [Cancel] to cancel and exit.</li></ol>
<b>Effects</b>	Enhance signals of one grey segment and the corresponding part of the image becomes brighter. Reject signals of one grey segment and the corresponding part of the image becomes darker. Adjusting one node will also influence shape of adjacent segments.
<b>Impacts</b>	The adjustment will not influence the cine review.
<b>Operation Conflicts</b>	It can be adjusted when the image is frozen.

## ■ Rejection

<b>Description</b>	Suppress the image signal below a certain gray scale.
<b>Operations</b>	<ol style="list-style-type: none"><li>1. Click [Post Process]→[Grey Rejection] of B or M image menu to open the “Grey Rejection” dialog box.</li><li>2. Move cursor to the “▲” node, and the cursor turns to “⊕”. Press &lt;Set&gt; and roll the track ball to move the “▲” node to adjust the grey rejection curve, and the effect of image changes with the grey rejection.</li><li>3. At this moment,<ul style="list-style-type: none"><li>● When getting the required effect, press &lt;Set&gt; to confirm and the cursor turns back to “⊕”. Or</li><li>● Press &lt;Back&gt; to cancel moving the node and the node returns to the original position.</li></ul></li><li>4. Click [OK] to confirm and exit or click [Cancel] to cancel and exit.</li></ol>
<b>Effects</b>	The rejected segment is black.
<b>Impacts</b>	The adjustment will not influence the cine review.
<b>Operation Conflicts</b>	It can be adjusted when the image is frozen.

## ■ $\gamma$

<b>Description</b>	Modifies the nonlinear distortion of the image. $\gamma$ correction has four grades, 0, 1, 2 and 3 corresponding to $\gamma$ correction coefficients 1.0, 1.1, 1.2 and 1.3, respectively.
<b>Operations</b>	Move cursor to [Post Process]→[ $\gamma$ (value)], and press <Set> to increase the value or press <Back> to decrease the value.
<b>Effects</b>	/
<b>Impacts</b>	The adjustment will not influence the cine review.
<b>Operation Conflicts</b>	It can be adjusted when the image is frozen.

- Grey Invert: Reverse the polarity of the image. Click [Post Process]→[Grey Invert On/Off] to turn on/off Bipolar Rev.

## 4.3 M Mode

The adjustment to Gain, Dynamic Range and Post Process are the same as those in B mode.

### 4.3.1 M Speed

<b>Description</b>	Adjusts the refresh speed of M-mode image. Its range is 1~4. 1 indicates fastest scanning speed while 4 the slowest.
<b>Operations</b>	Press <Menu> to open the M Img Menu, and move cursor to [M Speed (1~5)]. Then press <Set> to increase the value or press <Back> to decrease the value.
<b>Effects</b>	The greater the value of M Speed, the slower the scanning speed. The smaller the value of M Speed, the faster the scanning speed.
<b>Impacts</b>	Adjusting M Speed will clear the cine memory.

**Operation Conflicts** M speed cannot be adjusted when the image is frozen.

### 4.3.2 Edge Enhance

**Description** The range of “Edge Enhance” is 0~4. 0 represents no Edge Enhance and 4 represents maximum Edge Enhance.

**Operations** Press <Menu> to open M Img Menu, and move cursor to [Edge Enhance (value)]. Press <Set> to increase the Edge Enhance and press <Back> to decrease the Edge Enhance. The value is displayed in the menu.

**Effects** /

**Impacts** The adjustment to Edge Enhance will influence the cine review.

**Operation Conflicts** The Edge Enhance cannot be adjusted when the image is frozen.

### 4.3.3 M Soften

**Description** Adds up the scanning lines of M-mode image and calculate the average value in order to remove the noise on the image and make the image details clearer. Its range is 0~15.

**Operations** Press <Menu> to open the M Img Menu, and move cursor to [M LineCorre (0~15)]. Then press <Set> to increase the value or press <Back> to decrease the value.

**Effects** Removes noises in the image.

**Impacts** The adjustment to M LineCorre will influence the cine review.

**Operation Conflicts** M LineCorre cannot be adjusted when the image is frozen.



# 5 Annotating the Image

---

This chapter introduces how to add comments and body mark to ultrasound image.

## 5.1 Comments

Comments can be added to real-time image, frozen image, cine review image and zoomed image.

**⚠ WARNING:** You must ensure that the entered comments are correct. Incorrect comments may cause misdiagnosis!

- To enter comment status:
  - Press <Comment> to enter comment status. Or,
  - Move cursor to where you want to add comments, and then press alphanumeric keys to enter the corresponding characters and enter comment status.
- To exit comment status:

In comment status,

  - Press <Comment> to exit comment status. Or,
  - Press <Esc> to exit comment status.

### 5.1.1 Adding Comments

- Inputting comments with keyboard
  1. Move cursor to the desired position.
  2. Press the alphanumeric keys to enter comment status and insert corresponding characters. Upper case letters are inserted by default.
    - To input lower case letters, press <Caps Lock>;
    - Press <Shift> and alphanumeric keys simultaneously to shift to opposite or input symbols on the upper part of the button.
  3. To end inputting comments,
    - Move the cursor to confirm and end adding comments. The cursor turns to non-editing status.
    - Press <Enter> to confirm and end adding comments. The cursor turns to non-editing status and start a new line.
    - Press <Set> to confirm and end adding comments. The cursor turns to non-editing status and start a new line.
    - Press <Back> to cancel and delete the current comment.
- Add comments from comments library (search word by the first letter)
  1. Move cursor to where you want to add comments.
  2. Press alphanumeric keys to enter comment status and insert corresponding characters.
  3. Rotate the left <Multifunctional Knob>, the system searches the word begins with the inputted letter and displays them circularly.
  4. To end adding comments,
    - Move cursor to cancel and end adding comments.

- Press <Enter> to add the selected comment and end adding comments. The cursor turns to non-editing status and start a new line.
- Press <Set> to add the selected comment and end adding comments. The cursor moves to the end of the comments.
- Add comments from comments library (select word in the menu)
  1. Move cursor to where you want to add comments. Press <Set> to set the initial position. You can also move the comment later. If initial position is not set, the comments will be added to behind the last editing position.
  2. Press <Menu> to open the comment menu.
  3. Select a comment in the menu and press <Set> to activate it and move it to the initial position.
  4. Move the comment with the track ball.
  5. Press <Set> to confirm.

### 5.1.2 Adding Arrow

1. Move cursor to where you want to add arrow. You can also move the arrow later.
2. Press <Arrow> to add arrow. The cursor turns to a selected arrow.
3. The “Rotation” indicator of left <Multifunctional Knob> lights up. Rotate the knob to change the direction of the arrow by 15 degrees.
4. Press <Set> to confirm and continue adding arrow or press <Back> to delete the last arrow. Press <Arrow> to exit arrow mode.

### 5.1.3 Moving Comments/Arrows

1. Move cursor to the comment/arrow that you want to move, and the cursor changes to “↕”.
2. Press <Set> to select the comment/arrow and the cursor changes to the frame of the comment/arrow.
3. Move the frame of the comment/arrow to a new position with the track ball.
4. Press <Set> to confirm.

### 5.1.4 Editing Comments

1. Move cursor to the comment to be edited, and press <Set> twice to enter comment editing status.
2. Move cursor to the editing position with the direction buttons. Press <Del> to delete the character on the right of the cursor, and press <Backspace> to delete the character on the left of the cursor.
3. Press <Set> to confirm and exit or press <Back> to cancel and delete the current comment.

### 5.1.5 Deleting Comments/Arrows

1. Move cursor to the desired comment/arrow and the cursor turns to “↕”. Press <Set> to select the comment/arrow.
2. Press <Back> or <Del> to delete the comment/arrow.
- Press <Clear> to clear the screen.

## 5.2 Body Mark

Body mark indicates the posture of patients and orientation of transducer during ultrasonic exam. It is an additional remark to the ultrasonic image.

### 5.2.1 Adding Body Mark

1. Press <Body Mark> to open the “BodyMark Lib” dialog box.
2. Move cursor to the desired body mark and press <Set> to add the body mark to the image.
3. Roll the track ball to move the transducer mark and rotate the left <Multifunctional Knob> to rotate the transducer mark.
4. Press <Set> to confirm.

In dual B/quad B mode, you can add body mark into the two/four images respectively.

### 5.2.2 Moving the Body Mark

1. Move cursor to the body mark and the cursor turns to “”. Press <Set> to select the body mark and the cursor turns to the frame of the body mark.
2. Move the frame of the body mark to the desired position with the track ball.
3. Press <Set> to confirm.

### 5.2.3 Editing the Body Mark

1. Move cursor to the transducer mark of the body mark and press <Set> twice. The cursor turns to the transducer mark.
2. Roll the track ball to move the transducer mark and rotate the <Multifunctional Knob (R)> to rotate the transducer mark.
3. Press <Set> to confirm and exit.

### 5.2.4 Deleting the Body Mark

To delete the body mark:

- Double-click <Body Mark> to delete the body mark of current window.
- Press <Clear> to clear all the body marks.





# 6 Auxiliary Functions

---

## 6.1 Biopsy Guide

For details about the probes, needle-guided brackets and biopsy guide, please refer to “8 Probes and Biopsy”.

### 6.1.1 Basic Operations

**⚠ WARNING:** Do not freeze the image while performing biopsy.

- To enter biopsy mode: Press <Menu> to open the B image menu, and then click [Biopsy] to open the biopsy menu and enter biopsy mode. In M+B mode, you need to switch to B Img Menu.
- In the biopsy menu,
  - [NGB Model (Model)]: If the brackets for current transducer are more than one, click this item to switch brackets.
  - [Guideline (All/A/B/C)]: To select the guide line to be displayed.
  - [Display (On/Off)]: To display/hide the guide line.
  - [Dot Size (Small/Medium/Large)]: To set the size of dots in the guide line.
  - [Verify]: Click [Verify] to open the “Biopsy Verify” menu and verify the biopsy guide line.

### 6.1.2 Adjusting the Guide Line

**⚠ WARNING:**

1. Prior to each puncture, calibrate the needle guide line.
2. If the positions of the needle and needle guide line are not consistent, do not execute needle guide operation.

**NOTE:** The B-Mode image must be live and active to verify the onscreen biopsy guideline.

In the “Biopsy” menu, click [Verify] to open the “Biopsy Verify” menu.

In the “Biopsy Verify” menu,

- [Guideline (All/A/B/C)]: To switch among guide lines.
- [Position (Value)]: Move the cursor to this item, and then press <Set> or <Back> to move the guide line. It is available only when one guide line is displayed.
- [Angle (Value)]: Move the cursor to this item, and then press <Set> or <Back> to rotate the guide line. It is available only when one guide line is displayed.
- [Save]: To save the direction and position of current guide line.
- [Load Factory]: To load factory configuration of current guide line.
- [Exit]: To return to the “Biopsy” menu and display the guide lines as just set.

## 6.2 Lithotripsy

“Lithotripsy” helps to locate the focus point of lithotripsy wave during lithotripsy treatment. By watching the procedure of lithotripsy in real-time and adjusting the intensity and frequency of the lithotripsy wave, the harm to the patients can be reduced to the least.

To use “Lithotripsy”, please enable “Lithotripsy” first in “Preset→System Preset→Image Preset”.

- To enter lithotripsy mode: Press <Menu> to open the B Img Menu, and then click [Lithotripsy] to open the lithotripsy menu and enter lithotripsy mode. In M+B mode, you need to switch to B Img Menu.
- In “Lithotripsy” menu:
  - [Display (On/Off)]: To display or hide the lithotripsy guide line.
  - [Dot Size (Small/Middle/Large)]: To set the size of dots in the guide line.
  - [Exit]: To exit “Lithotripsy” menu.
- In lithotripsy mode:
  - The lithotripsy line is a vertical dotted line located in the middle of the screen, the position and direction of which cannot be changed.
  - The lithotripsy mark is a “×” mark located on the lithotripsy line which can be moved up and down along the lithotripsy line: Roll the track ball downwards to move the mark downwards, and roll the track ball upwards to move the mark upwards.
  - The depth of the mark is displayed in the lower, right corner of the screen.

# 7 File Management

---

## 7.1 Formats of Files

- File formats adopted by the diagnostic system only:
  - FRM: System-defined single-frame static file format, non-compressed format, used for measurements and comments.
  - CIN: System-defined multi-frame file format; you can perform manual or auto cine review, and perform measurements or add comments to the reviewed images. After you open stored a CIN file, the system automatically enters cine review status.
- File formats that are compatible with personal computers:
  - BMP: Single-frame file format, used to save the current screen, non-compressed format;
  - JPG: Single-frame file format, used to save the current screen in the compressed format; you can set the compression ratio.
  - DICOM file (DCM): DICOM standard files format, single-frame or multi-frame format. Available for systems with DICOM only.
  - AVI: Multi-frame file format.

## 7.2 Saving Files

- During an exam,
  1. Press <Freeze> to freeze the image.
  2. Press <Menu> to open the freeze menu.
  3. In the Freeze Menu, move the cursor to [Save As...] and click a format in the sub menu to save image or cine files to USB storage device.
- Save a file quickly: During an exam, press <Save1> or <Save2> to save the current screen to image file as preset format.

## 7.3 File Management

- To open the file manager
  1. Press <Freeze> to freeze the image.
  2. Press <Menu> to open the freeze menu.
  3. Click [File Manager] to open the file manager.
- To create a directory:
  1. Select a driver in the drives list.
  2. To select the path:
    - Double click a directory to enter.
    - Double click ".." to return to the father directory.
  3. Click [New], and a dialog pops up. Input the name of the new directory in the dialog box.
  4. Click [OK] to confirm or click [Cancel] to cancel.

- To delete a file/directory:
  1. Select a driver.
  2. Select the path.
  3. Select the file/directory to be deleted and click [Delete].
  4. Click [OK] to confirm deleting, or click [Cancel] to cancel.
- To rename a file/directory:
  1. Select a driver.
  2. Select the path.
  3. Select the file/directory to be renamed and click [Copy].
  4. Input the new name of the file/directory.
  5. Click [OK] to confirm or click [Cancel] to cancel.
- To copy a file/directory:
  1. Select the path of the source file/directory.
  2. Select the file/directory to be copied and click [Copy].
  3. Select the path of the destination file/directory.
  4. Click [Paste].
  5. If the file/directory to be pasted already exists, a dialog box pops up. Click [OK] to confirm overwriting, or click [Cancel] to cancel copying.

## 7.4 iVision

iVision is used for presentation of images, in which images (including formats of ultrasonic system and standard formats) are displayed one by one in the sequence of file name. The formats supported by the system are: JPG, BMP, DCM single frame and FRM. The formats not supported are: AVI and DCM multi frames.

- To enter iVision
  1. Press <Freeze> to freeze the image.
  2. Press <Menu> to open the freeze menu.
  3. Click [iVision] to open iVision.

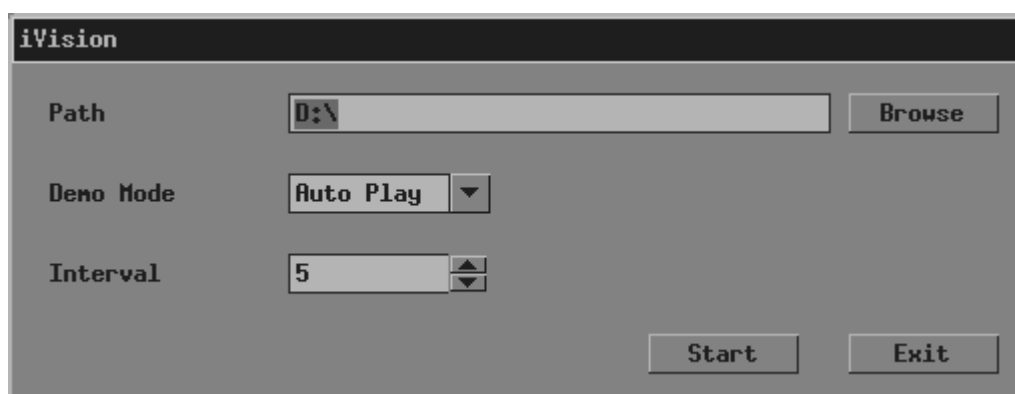



- In the “iVision” dialog box
  - [Browse]: To select the directory of presentation.
  - [Demo Mode (Auto Play/Manual Play)]: To select the mode of playback.
  - [Interval (time)]: To set the time interval of playback when “Auto Play” is selected. Click [▲] and [▼] to change the time interval.
  - [Start]: To start playback.
  - [Exit]: To exit iVision.
- Manual Playback
  - If “Manual Play” is selected, press the directions <←> and <→> to play the images.
- To exit iVision
  - When reviewing CIN files, press <Freeze> to exit iVision.
  - When reviewing files of other formats, click [Exit] to exit iVision.
  - Press <Esc> to exit iVision.



# 8 Probes and Biopsy

## 8.1 Probes

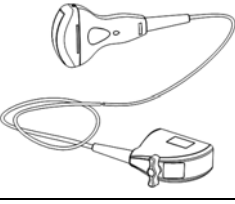
The system supports the following probes:

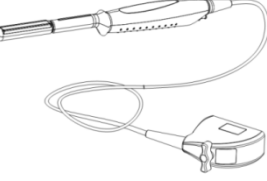
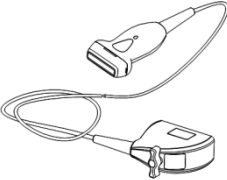
No.	Probe Model	Illustration
1.	35C20EA	 A line drawing of a probe with a curved handle and a long, thin cable. The handle has a small circular feature. The cable ends in a rectangular connector with a latch.
2.	35C50EB	 A line drawing of a probe with a curved handle and a long, thin cable. The handle has a small circular feature. The cable ends in a rectangular connector with a latch.
3.	65C15EA	 A line drawing of a probe with a curved handle and a long, thin cable. The handle has a small circular feature. The cable ends in a rectangular connector with a latch.
4.	65EC10EB	 A line drawing of a probe with a straight handle and a long, thin cable. The handle has a small circular feature. The cable ends in a rectangular connector with a latch.
5.	65EL60EA	 A line drawing of a probe with a straight handle and a long, thin cable. The handle has a small circular feature. The cable ends in a rectangular connector with a latch.
6.	75L38EB	 A line drawing of a probe with a straight handle and a long, thin cable. The handle has a small circular feature. The cable ends in a rectangular connector with a latch.

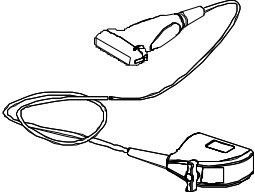
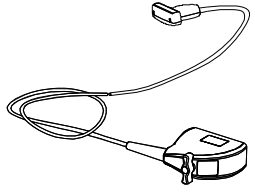
7.	75L53EA	
8.	75LT38EA	

**NOTE:** For details of storage time and condition for disinfected probes or sterilized probes and brackets, please refer to Technical standard for Disinfection of Medical and Health Structures

Some of the probes have matched needle-guided brackets for biopsy, the available probes and the corresponding needle-guided brackets are listed as follows:

Probe Model	Needle-guided Bracket Model	Biopsy Angle/Depth	Type	Applicable Biopsy Needle
35C20EA	NGB-003	11°, 23°	Metal/needle un-detachable	13G, 15G, 16G, 18G, 20G
			Metal/needle detachable	14G, 16G, 18G, 20G, 22G
35C50EB	NGB-001	25°, 35°, 45°	Metal/needle detachable	14G, 16G, 18G, 20G, 22G
			Metal/needle un-detachable	13G, 15G, 16G, 18G, 20G
65C15EA	NGB-005	12.7°, 24.2°	Metal/needle un-detachable	13G, 15G, 16G, 18G, 20G
65EC10EB	NGB-004	/	Metal/needle un-detachable	16G, 17G, 18G
65EL60EA	NGB-009	0°	Metal/needle detachable	13G, 15G, 16G, 18G, 20G
75L38EB	NGB-002	40°, 50°, 60°	Metal/needle un-detachable	13G, 15G, 16G, 18G, 20G
75L53EA	NGB-007	40°, 50°, 60°	Metal/needle detachable	14G, 16G, 18G, 20G, 22G
			Plastic/needle detachable	13G, 15G, 16G, 18G, 20G



Probe Model	Needle-guided Bracket Model	Biopsy Angle/Depth	Type	Applicable Biopsy Needle
75LT38EA	NGB-010	30°, 40°, 50°	Metal/needle detachable	13G, 15G, 16G, 18G, 20G

### 8.1.1 Name and Function of Each Part of the Probe

The basic structures and corresponding functions of probes are basically the same; the following will take probe 35C20EA as an example.

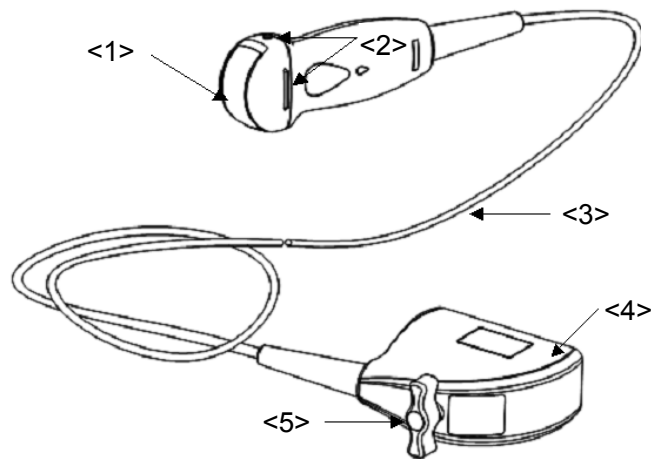

No.	Name	Function
<1>	Probe head	It converts the electrical signal into ultrasound signal, making the sound beams focus in the given direction; meanwhile, it will receive the ultrasound signal and then convert the received signal into electrical signal. The lens on the surface is the acoustic lens. Apply ultrasound gel on the acoustic lens.
<2>	Needle-guided bracket fix tabs and grooves	Used to mount the needle-guided bracket.
<3>	Probe cable	Used to transmit electrical signals between the probe body and connector.
<4>	Probe connector	Used to connect the probe to the ultrasonic diagnostic system.
<5>	Lock handle	Used to lock the connector to the ultrasonic diagnostic system.

Tips:

The probes' structure marked <2> in the figure above may vary with the matched needle-guided brackets.

65EL60EA:

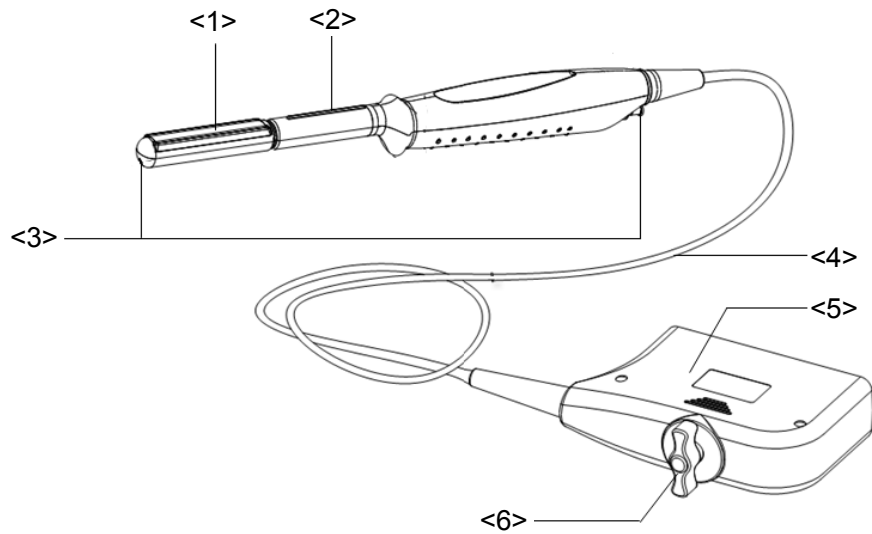

No.	Name	Function
<1>	Transducer head	It utilizes the piezoelectric effect to convert electrical signals into ultrasound waves, which are transmitted to the body, and to generate electrical signals when receiving the reflected ultrasound waves (echoes). The lens on the surface is the acoustic lens. Apply ultrasound gel on the acoustic lens.
<2>	Needle-guided bracket fix tab	Mount the needle-guided bracket using this tab.
<3>	Water injection/drainage port	Used for inject/drain water
<4>	Cable	This transmits electrical signals between the transducer body and connector.
<5>	Connector	This connects the transducer to the ultrasonic diagnostic system.
<6>	Lock handle	This locks the connector to the ultrasonic diagnostic system.

## 8.1.2 Orientation of the Ultrasound Image and the Probe

### Head

The orientation of the ultrasound image and the transducer are shown as below. The “Mark” side of the ultrasound image on the monitor corresponds to the mark side of the transducer. Check the orientation before the examination.

#### ■ Method 1

The arrow on the ultrasound image is corresponding to the O mark on the transducer (taking convex transducer as an example).

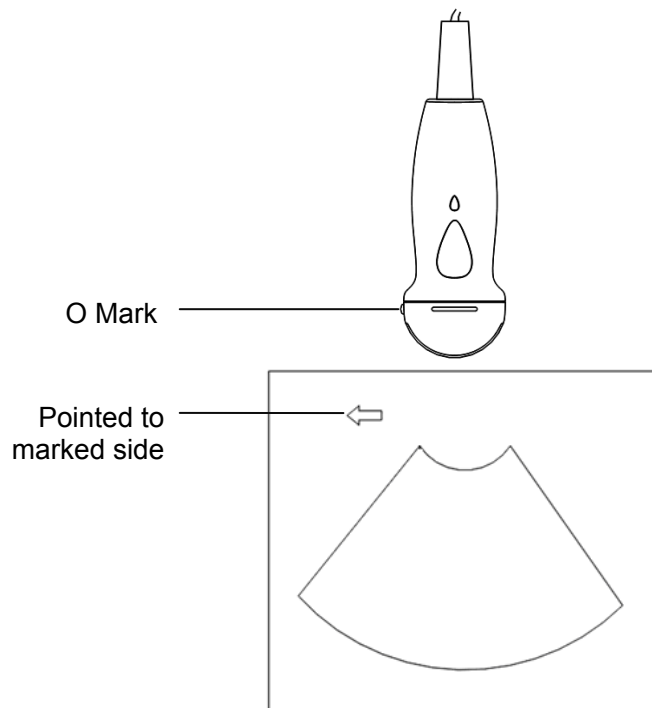

■ Method 2

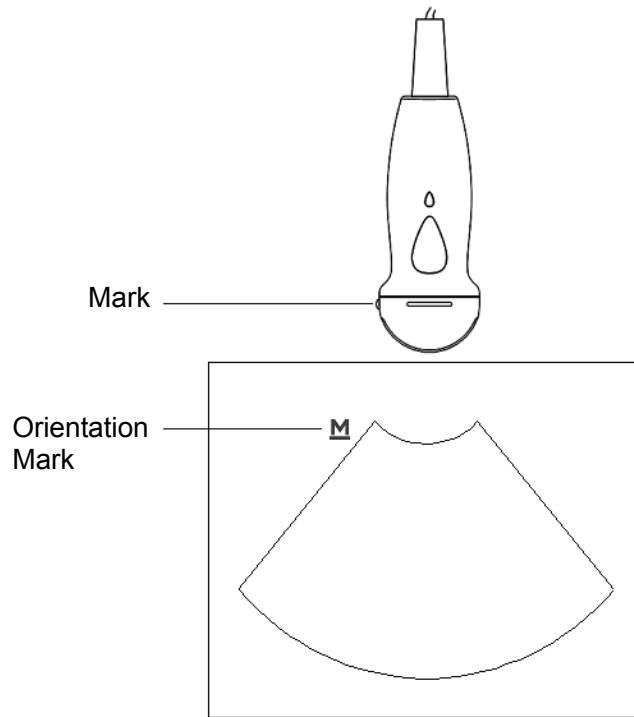

### 8.1.3 Procedures for Operating

This section describes general procedures for operating the probe. The proper clinical technique to be used for operating the probe should be selected on the basis of specialized training and clinical experience.

Procedures for operating (with biopsy function):

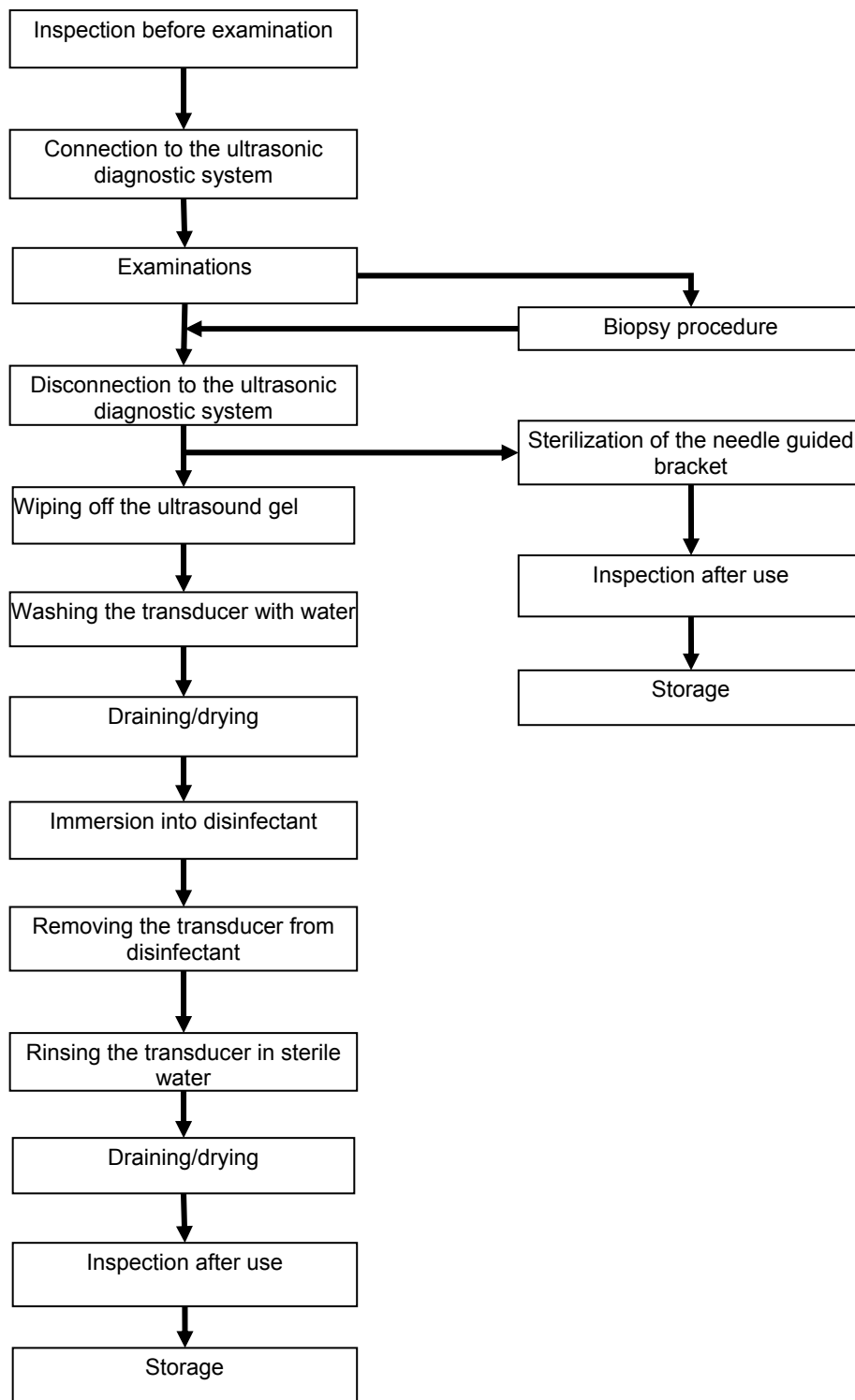

Procedures for operating (with no biopsy function):

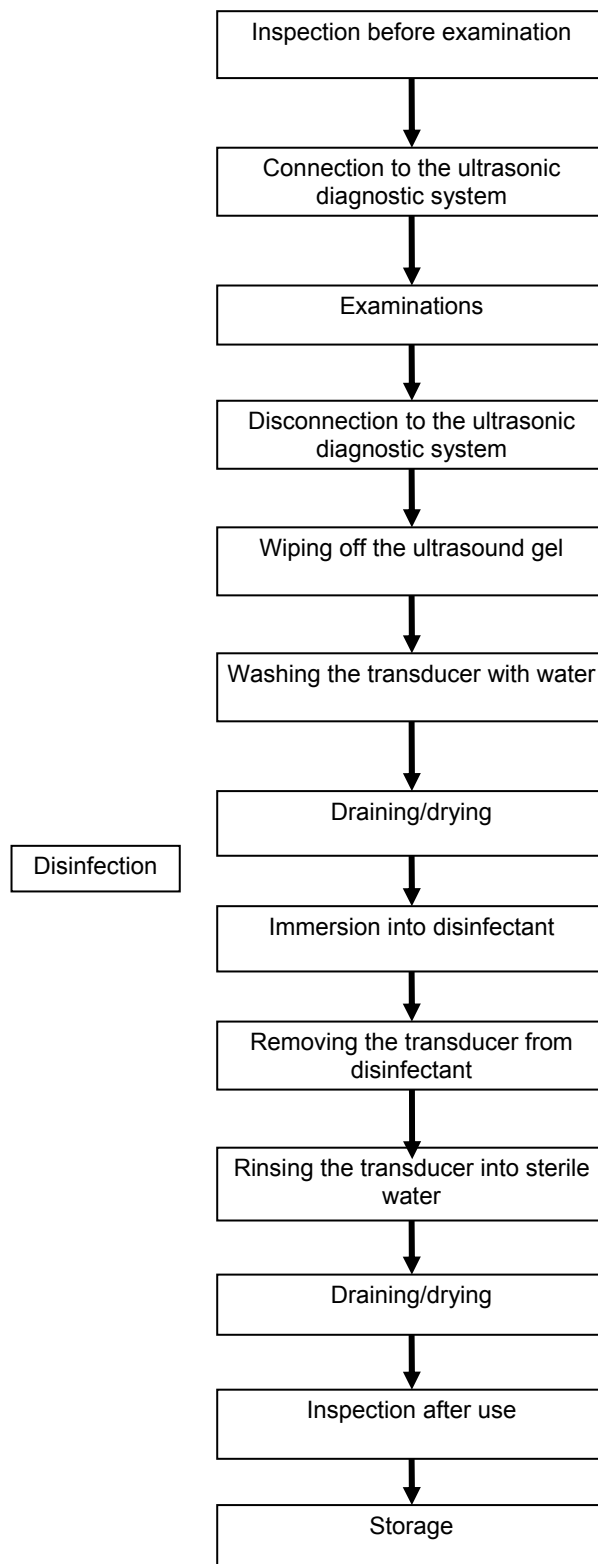

**⚠️ WARNING:** Disinfect the probe and sterilize the needle-guided bracket before and after an ultrasound-guided biopsy procedure is performed. Failure to do so may cause the probe and the needle-guided bracket become source of infection.

## 8.1.4 Wearing the Probe Sheath

A legally marketed probe sheath must be installed over the probe before performing intra-cavitary and intra-operative examination. Protective barriers may be required to minimize disease transmission. Probe sheaths are available for use with all clinical situations where infection is a concern.

To order probe sheath, contact:

CIVCO Medical Instruments Co.

102 First Street South, Kalona, IA 52247-9589 USA Tel: 1-319-656-4447

E-mail: [info@civco.com](mailto:info@civco.com)

<http://www.civco.com>

**⚠ CAUTION:**

1. Be sure to cover the probe with a new (unused) probe sheath to prevent infection during examination. If the package of a probe sheath is open or broken, the sterilization of the probe sheath may not be sufficient. **DO NOT** use such a probe sheath.
2. The cover contains natural rubber latex and talc that can cause allergic reactions in some individuals.
3. **DO NOT** use an expired probe sheath. Before using probe sheaths, verify whether the term of validity has expired.

Method (for reference only):

1. Place an appropriate amount of gel inside the sheath or on probe face. Poor imaging may result if no gel is used.

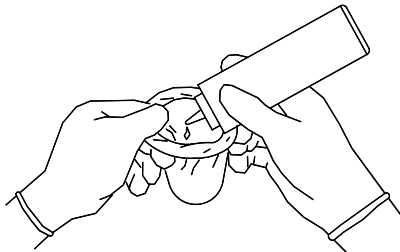

2. Insert the probe into the sheath, make sure to use proper sterile technique. Pull cover tightly over probe face to remove wrinkles and air bubbles, taking care to avoid puncturing cover.

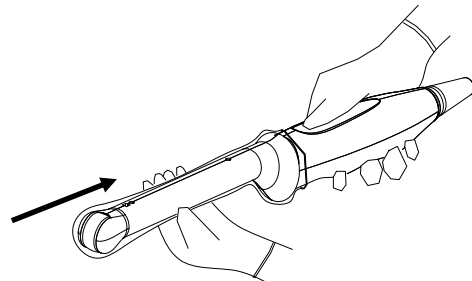

3. Secure the sheath with enclosed elastic bands.

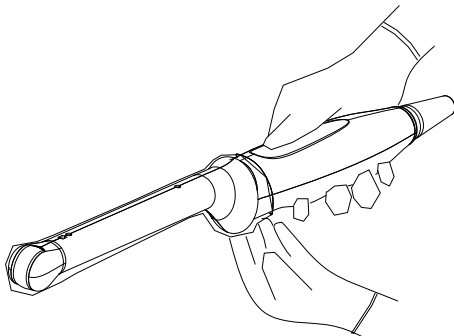

4. Inspect the sheath to ensure there are no holes or tears.

## 8.1.5 When the Immersion Method is Used

MINDRAY recommend a syringe: CIVCO 610-224

Please perform the following operations before using the syringe.

1. Open the syringe pack and take out the syringe.
2. See the following figure, take out the dustproof cap at the end of the syringe's extension tube.



3. See the following figure, push back the locking nut and make the connector come out. The connector will be connected to the transducer's injection/drainage port.

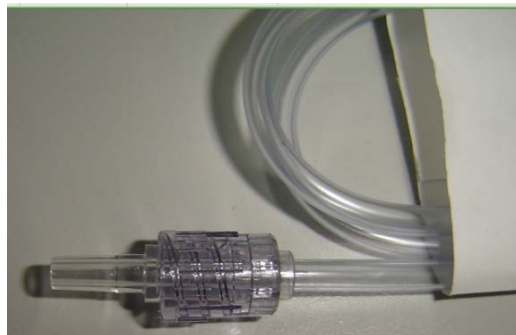

Please refer to the following operations When the Immersion Method is used.

1. Put on the transducer cover.  
For the procedures of putting on the transducer sheath, refer to subsection above. Check the transducer sheath for wrinkles and gaps.

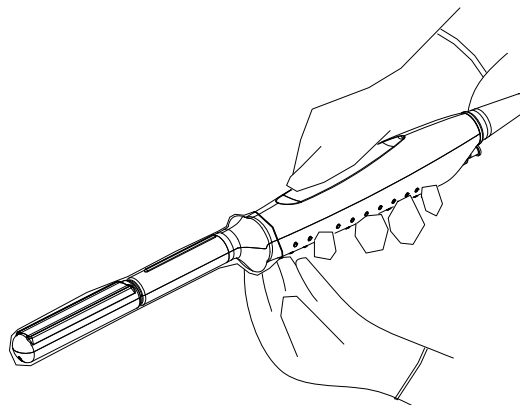



2. Fill syringe with sterile water and connect extension tube to syringe, discharge all air in the tube. Attach the syringe to transducer fill port.

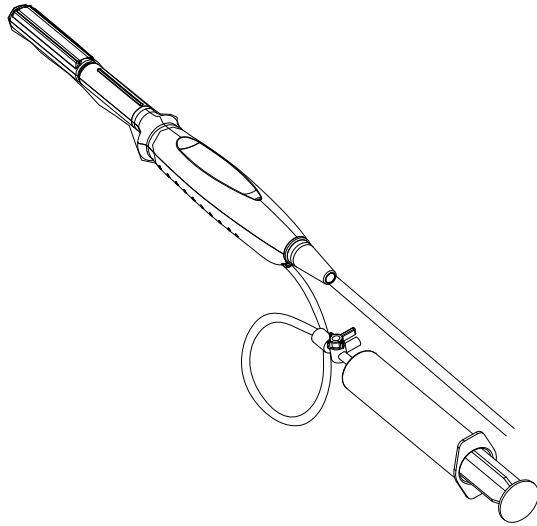

3. Orientate the transducer downward and inject sterile water up to the level a few cm above the end of the transducer surface.

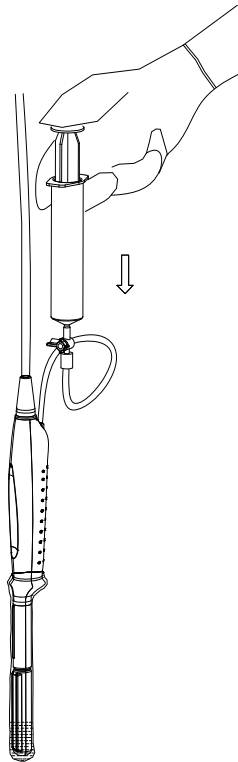

4. Orientate the transducer upward to discharge air in the transducer cover.

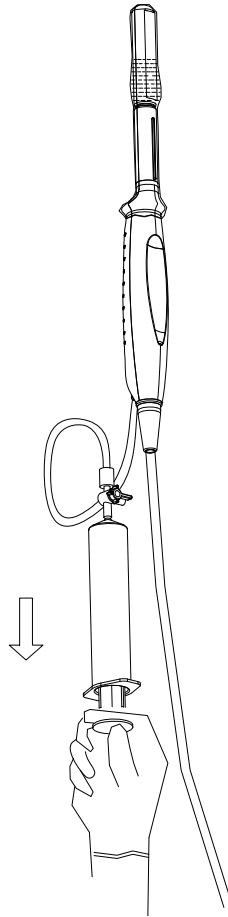

5. Turn the valve of the syringe to the position shown in the right figure, and then push the plunger of the syringe to discharge the air.

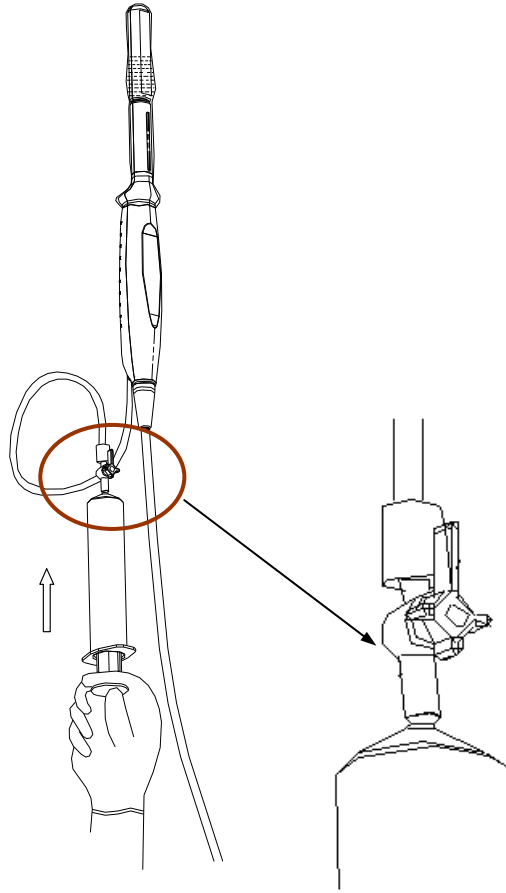

6. Return the valve of the syringe to the original position; orientate the transducer downward to discharge sterile water.

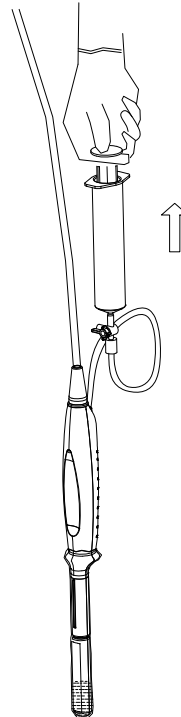

## 8.1.6 Probes Cleaning and Disinfection

Once you turn OFF the ultrasonic diagnostic system after completing each examination, clean and disinfect the probes as required. When biopsy procedures have been performed, be sure to sterilize the needle-guided bracket. Fail to do so may result in the probe and the needle-guided bracket to becoming sources of infection.

**⚠️WARNING:** Never immerse the probe connector into liquid such as water or disinfectant. Immersion may cause electrical shock or malfunction.

**⚠️CAUTION:** 1. When performing cleaning and disinfection of the probe to prevent infection, wear sterile gloves.



2. After disinfection, rinse the probe thoroughly with sterile water to remove all chemical residues. Chemical residues on the probe may be harmful to the human body.
3. The efficacy of disinfectants and sterilizing solutions is not guaranteed by MINDRAY. Contact the manufacturers for information on the activity of the products.

**NOTE:**

1. After the examination, wipe off the ultrasound gel thoroughly. Otherwise, the ultrasound gel may solidify and the image quality would be degraded.
2. DO NOT make the probe to become overheated (more than 55°C) during cleaning and disinfections. High temperature may cause the probe to become deformed or damaged.

### Cleaning

Please follow the instructions in the manual for cleaning.

1. Wear sterile gloves to prevent infection.
2. Wash the probe with water and remove all foreign matter. Soapy water may be used. A soft urethane sponge can be used to wash the probe. Avoid using a brush, because it may damage the probe.
3. Wipe off water on the probe using sterile cloth or gauze after washing it. DO NOT dry the probe by heating.

### High Level Disinfections

Please follow the instructions in the manual for disinfection.

1. Wear sterile gloves to prevent infection.
2. Clean the probe before disinfecting it. The probe manufacturer recommends the following solutions to disinfect the probe.

■ Glutaraldehyde-based disinfectant:

Chemical Name	Trade Name	Procedures
Glutaraldehyde (2.4%)	Cidex Activated Dialdehyde Solution	Please refer to the instructions provided by the manufacturer of the solution for details.

■ Non-glutaraldehyde based disinfectant:

Chemical Name	Trade Name	Procedures
Ortho-Phthalaldehyde (0.55%)	Cidex OPA	Please refer to the instructions provided by the manufacturer of the solution for details.

■ N-Dodecylpropane-1, 3-diamine based disinfectant:

Chemical Name	Manufacturer	Trade Name	Procedures
N-Dodecyl- lpropane-1, 3- diamine	Antiseptica	Triacid-N	Please refer to the instructions provided by the manufacturer of the solution for details.

■ Quaternary Ammoniums based disinfectant:

Chemical Name	Manufacturer	Trade Name	Procedures
Quaternary Ammoniums	Ecolab Inc.	Ster-Bac	Please refer to the instructions provided by the manufacturer of the solution for details.

■ Hydrogen Peroxide and Peroxyacetic Acid -based disinfectant:

Trade Name	Chemical Name	Procedures
Minnicare® Cold Sterilant	22% Hydrogen Peroxide 4.5% Peroxyacetic Acid	Please refer to the instructions provided by the manufacturer of the solution for details.

- Refer to the instructions provided by the chemical manufacturer concerning concentration of the disinfectant solution, method of disinfection and dilution and cautions during use.
  - DO NOT soak the probe connector or the cable near it into water or any solution.
  - Soak the probe into the disinfectant solution for the shortest time the manufacturer recommends (for example, the shortest time recommended by the manufacturer for soaking Cidex OPA is 12 minutes).
  - Follow local regulations when selecting and using the disinfectant.
3. Rinse the probe with plenty of sterile water (about 2 gallons) for at least 1 minute to remove all chemical residues on it. Or, follow the rinsing method recommended by the disinfectant

manufacturer to rinse the probe.

4. Wipe off the water on the probe with sterile cloth or gauze after rinsing it. DO NOT dry the probe by heating.

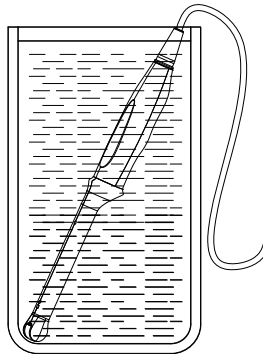

(For general transducer)

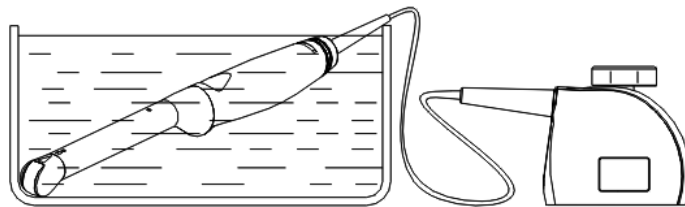

(For intra-cavitary transducer)

## Sterilization

For intra-operative probes, they have to be sterilized after completing each examination.

1. Wear sterile gloves to prevent infection.
2. Clean the probe before sterilizing it. MINDRAY recommends the following solutions to sterilize the probe.

Hydrogen Peroxide and Peroxyacetic Acid -based sterilization solution

Trade Name	Chemical Name	Procedures
Minnicare® Cold Sterilant	22% Hydrogen Peroxide 4.5% Peroxyacetic Acid	Dilute the sterilant with sterilized purified water (1:20). Immersed time: 11 hours. Temperature: 20°C-25°C. Please refer to the instructions provided by the manufacturer of the solution for details.

Before safety and performance is affected, probe 75LT38EA can be sterilized by Minncare COLD STERILANT for at least 135 times (11 hours for one time).

Glutaraldehyde-based sterilization solution

Trade Name	Chemical Name	Procedures
Cidex Activated Glutaraldehyde Solution	2.2-2.7% Glutaraldehyde	Soak the transducer into the activated solution for 10 hours (20-25°C) Please refer to the instructions provided by the manufacturer of the solution for details.

Before safety and performance is affected, probe 75LT38EA can be sterilized by Cidex Activated Glutaraldehyde Solution for at least 217 times (10 hours for one time).

- Refer to the instructions provided by the chemical manufacturer concerning concentration of the sterilization solution, method of sterilization and dilution and cautions during use.
  - Do not soak the probe connector or the cable near it into water or any solution.
  - Follow local regulations when selecting and using the sterilization solution.
3. Rinse the probe with plenty of sterile water (about 2 gallons) for at least 1 minute to remove all chemical residues on it. Or, follow the rinsing method recommended by the sterilization solution manufacturer to rinse the probe.
  4. Wipe off the water on the probe with sterile cloth or gauze after rinsing it. Do not dry the probe by heating.

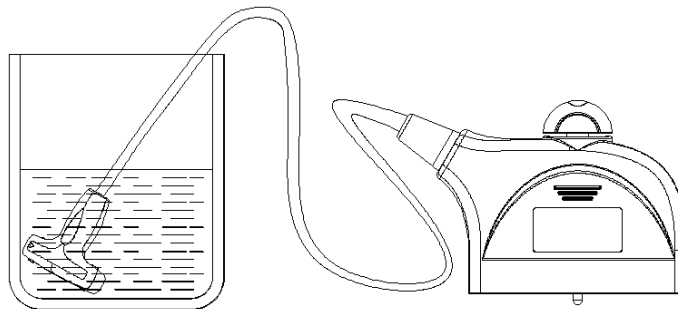

Immerse the 75LT38EA probe in the solution

**NOTE:** Repeated disinfection may degrade the performance and safety of the probe.

## 8.1.7 Storage and Transportation

When all examinations for the day have been completed, confirm that the probe is in good condition. After disinfecting the probe, confirm that the probe is in good condition and store it in a suitable place so that the next examination can be conducted smoothly.

1. To prevent the probe from being damaged, DO NOT store it in locations where it may be exposed to:
  - Direct sunlight or X-rays
  - Sudden changes in temperature
  - Dust
  - Excessive vibration
  - Heat generators
2. Store and transport the probe under the specified ambient conditions.
3. When the probe is sent to MINDRAY Customer Service Department or sales representative for repair, be sure to disinfect it and keep it in the carrying case to prevent infection.
4. Sterilize the carrying case as necessary.

## 8.2 Biopsy Guide

- ⚠WARNING:**
1. The person performing biopsy procedures must understand diagnostic ultrasound thoroughly and have been trained adequately, otherwise, side effects may be caused to the patient.
  2. In situations listed below, the biopsy needle may fail to penetrate the target. The incorrect biopsy may cause various side effects in the patient.
    - Use a needle-guided bracket other than that provided.
    - Mount the needle-guided bracket incorrectly.
    - Use a biopsy needle that is unsuitable for the type of biopsy being performed.
    - Use a biopsy needle that is unsuitable for the needle guide.
  3. Before and after a biopsy procedure is performed, confirm that the needle-guided bracket is normal. Manually confirm that the parts of the needle-guided bracket do not slip off or move from their proper positions. If the needle-guided bracket is used when parts are not securely and correctly installed, the patient may be injured. If an abnormality is found on the needle-guided bracket, immediately stop using it and contact MINDRAY Customer Service Department or sales representative.
  4. **DO NOT** use a needle-guided bracket when scanning is performed. The needle may advance in an incorrect direction and possibly injure the patient.

Never perform a biopsy during image scanning.
  5. **DO NOT** freeze an image while performing biopsy procedure.
  6. During biopsy procedures, the needle may deviate from the desired course due to the tissue characteristics or the type of needle. In particular, needles of small diameters may deviate to a greater degree.
  7. Sterilize the probe and the needle-guided bracket before and after each ultrasound-guided biopsy procedure is performed. Fail to do so may cause the probe and the needle-guided bracket become sources of infection.
  8. The needle mark displayed on the ultrasound image does not indicate the actual position of the biopsy needle. Therefore, it should only be used as a reference. Always monitor the relative positions of the biopsy needle during the procedures.
  9. Adjust the needle mark before the biopsy procedure is performed.
  10. When performing biopsy procedures, use only sterile ultrasound gel that is certified to be safe. And manage the ultrasound gel properly to ensure that it does not become a source of infection.
  11. When performing the operation concerning biopsy, wear sterile gloves.
  12. Image of the biopsy target and the actual position of the biopsy needle:

Diagnostic ultrasound systems produce tomographic plane



images with information of a certain thickness in the thickness direction of the probe. (That is to say, the information shown in the images consist all the information scanned in the thickness direction of the probe.) So, even though the biopsy needle appears to have penetrated the target object in the image, it may not actually have done so. When the target for biopsy is small, dispersion of the ultrasound beam may lead to image deviate from the actual position. Pay attention to this.

If the target object and the biopsy needle appear in the image as shown in the figures below (For reference only):

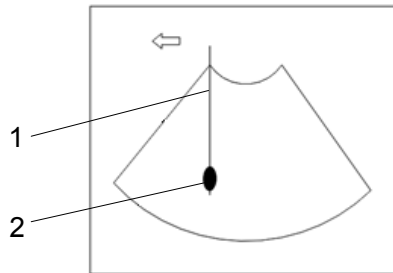

1. Biopsy 2. Target

The biopsy needle appears to reach the target object in the image

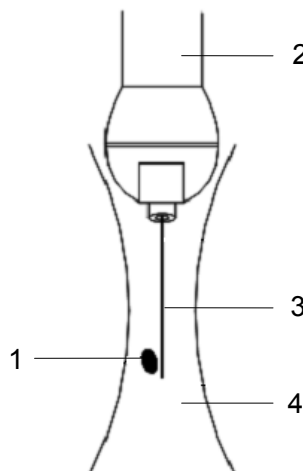

1. Target 2. Transducer 3. Needle 4. Ultrasound beam

Dispersion of the ultrasound beam

The biopsy needle may not have actually entered the target object even though it appears to have done so on the image. To avoid this problem, note points below:

- Do not rely only on the needle tip on the image. Pay careful attention to that, when the biopsy needle comes into the target object or contacts with it, the object should shift slightly.
- Before you perform the biopsy, please evaluate the size of the object and confirm if the biopsy can be carried out.

## 8.2.1 Needle-guided Brackets

A needle-guided bracket is available for purchase as an optional accessory; it is used in combination with the probe. Some of the probes have matched needle-guided bracket and needles. To order needle-guided brackets, contact MINDRAY Customer Service Department or sales representative.

For biopsy or treatment, ultrasound-guided biopsy procedures can be performed using the probe in combination with a needle-guided bracket (optional accessory) and a biopsy needle (provided by the user).

### Names of Parts

This section describes the parts and corresponding functions of each needle-guided bracket. Here, we take a matched probe as an example.

#### ■ NGB-001, NGB-002, NGB-003, and NGB-005 (Metal/needle un-detachable)

The structure of plastic needle-guided bracket NGB-001, NGB-002, NGB-003 and NGB-005 are similar to each other. The following figure shows the structure with NGB-001 as an example.

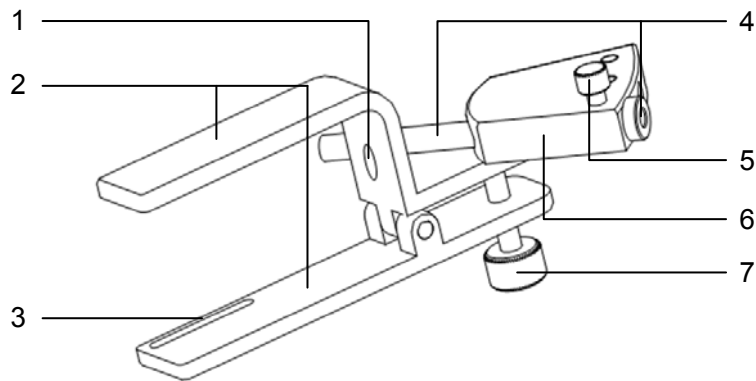

1. Locating pit 2. Clamp 3. Locating groove 4. Needle guide and the hole  
5. Clamping knob of the needle guide 6. Needle guide rack 7. Grip knob

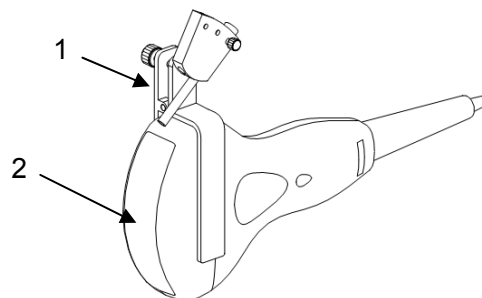

1. Needle-guided bracket 2. Transducer

■ NGB-001 (Metal/needle detachable)

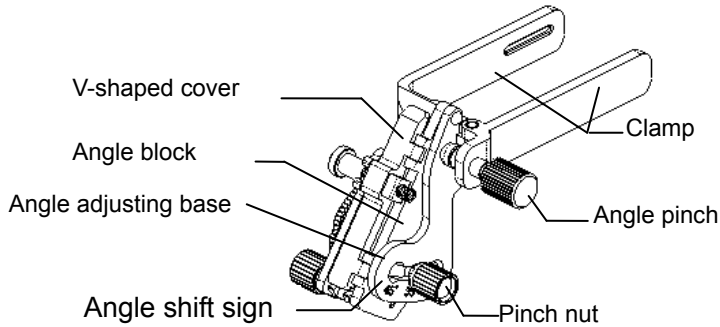
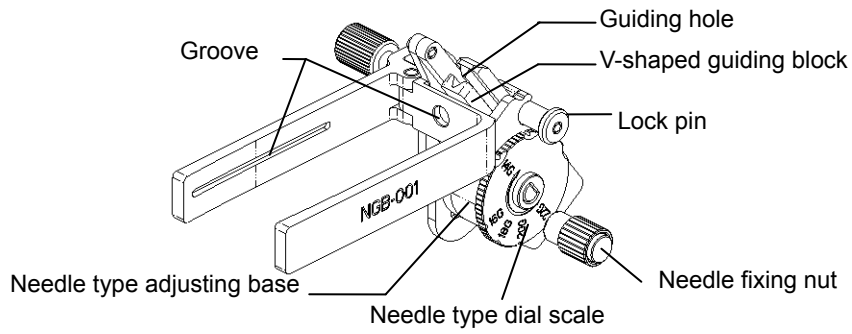

■ NGB-003 (Metal/needle detachable)

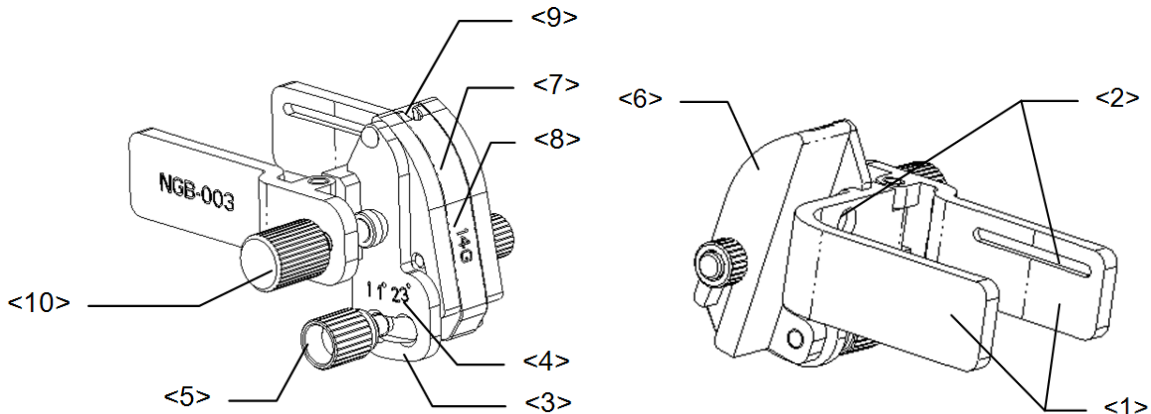

No.	Name	Description
<1>	Clamp of needle-guided bracket	Used for installing the needle-guided bracket on the transducer
<2>	Groove of the needle-guided bracket	Matches with the tab of the transducer
<3>	Angle adjusting base	There are 3 types of angles available to be adjusted
<4>	Angle shift sign(11° , 23° )	Matched with the biopsy angle(11° , 23° )
<5>	Angle pinch nut	Used for fixing the angle lock at a chosen angle
<6>	Angle block	Used for determining the angle of the biopsy; different specifications of blocks can be used
<7>	Guiding block	Used for installing biopsy needle; there are five specifications of guiding blocks for different biopsy needles

No.	Name	Description
<8>	Specification of guiding block(14G)	Matched with the corresponding biopsy needle(14G)
<9>	Needle guide hole	Used for installing the biopsy needle
<10>	Pinch nut of needle-guided bracket	Used for locking the needle-guided bracket and the transducer

■ NGB-004 (Metal/needle un-detachable)

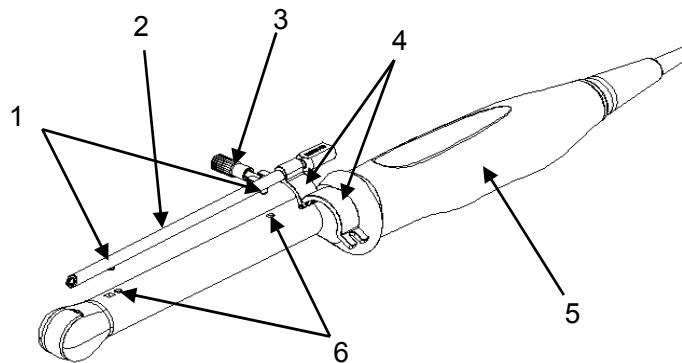

1. Locating bulge 2. Needle guide 3. Locking nut  
4. Retaining clamp 5. Transducer 6. Locating groove

■ NGB-007

Metal / needle detachable needle-guided bracket:

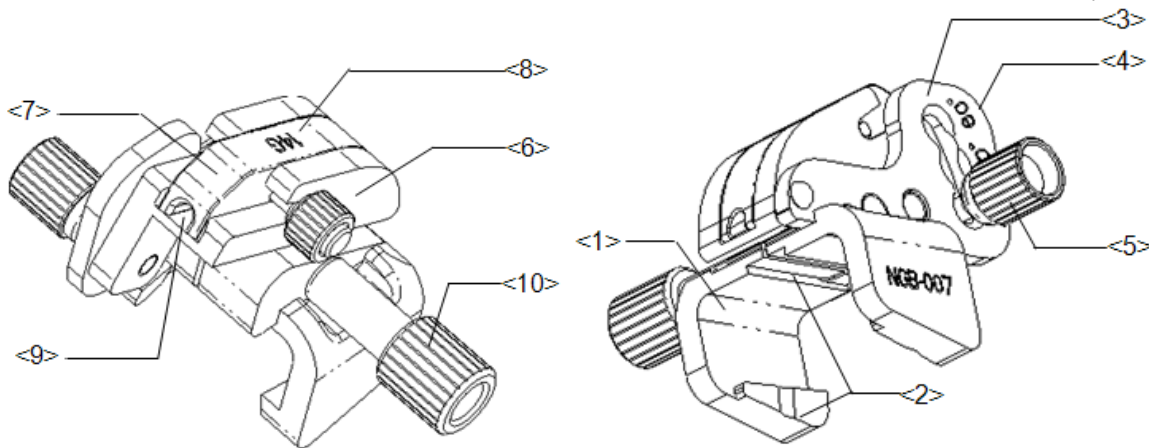

No.	Name	Description
<1>	Support of needle-guided bracket	Used for installing the needle-guided bracket on the transducer
<2>	Groove and tab of the needle-guided bracket	Respectively matched with the tab and groove of the transducer
<3>	Angle adjusting base	There are 3 types of angles available to be adjusted
<4>	Angle shift sign(40°,50°,60°)	Matched with the biopsy angle(40°,50°,60°)
<5>	Angle pinch nut	Used for fixing the angle lock at a chosen angle

No.	Name	Description
<6>	Angle block	Used for determining the angle of the biopsy; different specifications of blocks can be used
<7>	Guiding block	Used for installing biopsy needle; there are five specifications of guiding blocks for different biopsy needles
<8>	Specification of guiding block(14G)	Matched with the corresponding biopsy needle(14G)
<9>	Needle guide hole	Used for installing the biopsy needle
<10>	Pinch nut of needle-guided bracket	Used for locking the needle-guided bracket and the transducer

Plastic /needle detachable needle-guided bracket:

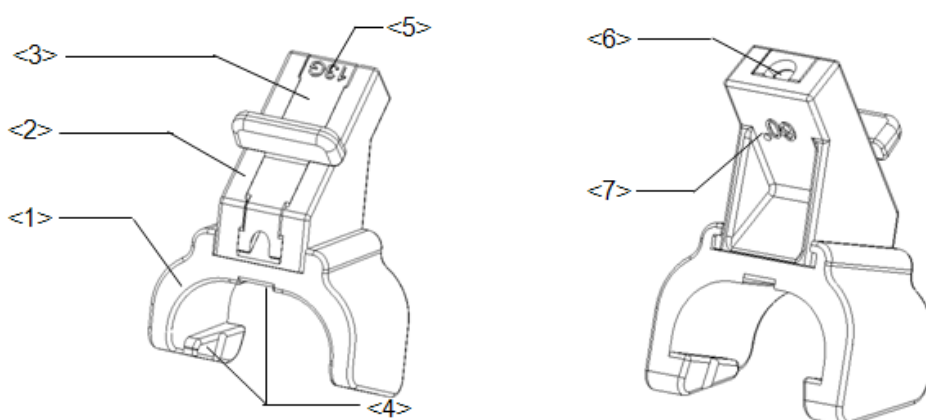

No.	Name	Description
<1>	Support of needle-guided bracket	Used for installing the needle-guided bracket on the probe.
<2>	Angle block	Used for determining the angle of the biopsy; there are three specifications of blocks of angle.
<3>	Guiding block	Used for installing biopsy needle; there are five specifications of guiding blocks for different biopsy needles.
<4>	Groove and tab of the needle-guided bracket	Respectively matches with the tab and groove of the probe.
<5>	Specification of guiding block (13G)	Matched with the corresponding biopsy needle (13G).
<6>	Guiding hole of the biopsy needle	Used for installing the biopsy needle.
<7>	Specification of angle block (60°)	The corresponding biopsy angle is 60°.

■ NGB-009 (Metal/needle detachable)

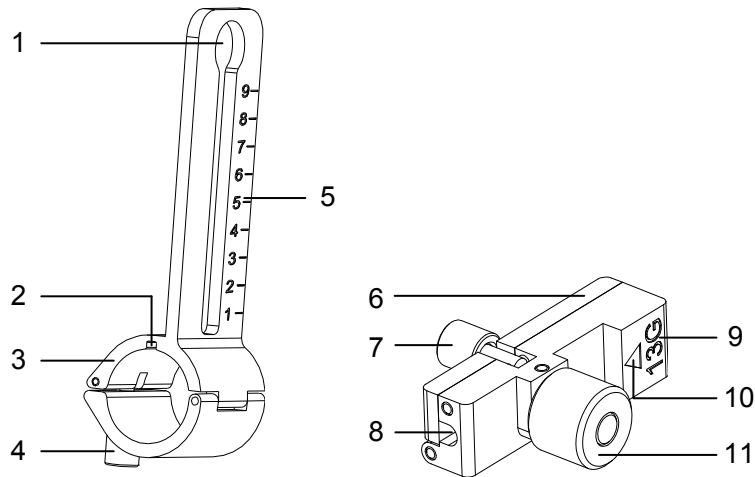

No.	Name	Description
1	Hole for installing guiding block	Used for installing the knob of fixing needle-guided bracket
2	Groove	Match with the tab on the transducer
3	Support of needle-guided bracket	Used for installing the needle-guided bracket on the transducer
4	Knob of fixing needle-guided bracket	Used for fixing the needle-guided bracket on the transducer
5	Needle distance scales	Indicate distance between needle and the transducer head surface
6	Guiding block	Used for installing biopsy needle; there are five specifications of guiding blocks for different needles
7	Knob of fixing the needle	Used for fixing the needle
8	Guiding hole of the needle	Used for installing the biopsy needle
9	Specification of guiding block	Matched with the corresponding biopsy needle
10	Mark of indicating scales	Indicating needle distance scales
11	Knob of fixing the guiding block	Used for fixing the guiding block

■ NGB-010 (Metal/needle detachable)

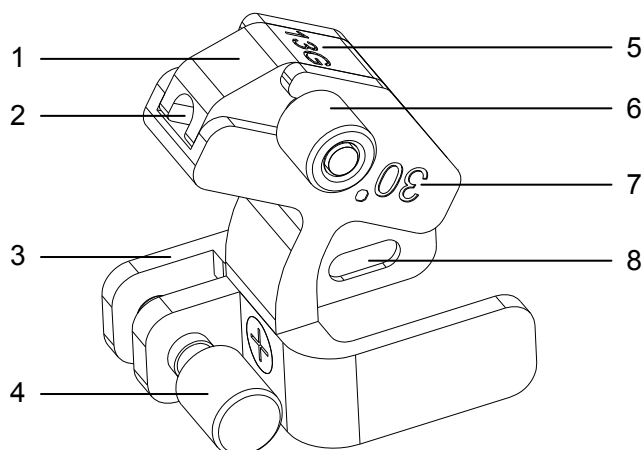

No.	Name	Description
1	Guiding block	Used for installing biopsy needle; there are five specifications of guiding blocks for different biopsy needles
2	Guiding hole of the biopsy needle	Used for installing the biopsy needle
3	Support of needle-guided bracket	Used for installing the needle-guided bracket on the transducer
4	Knob of fixing needle-guided bracket	Used for fixing the needle-guided bracket on the transducer
5	Specification of guiding block (13G)	Matched with the corresponding biopsy needle (13G)
6	Knob of fixing the guiding block	Used for fixing the guiding block
7	Needle guide angle	The needle guide angle of this needle-guided bracket
8	Grooves of the needle-guided bracket	Matched with the tabs of the transducer

## 8.2.2 Basic Procedures for Biopsy Guiding

1. Select the right needle-guided bracket and needle, install them properly. For details, please refer to “8.2.3 Needle-guided Bracket Inspection and Installation”.
2. Verify the biopsy guide line. For details, please refer to “8.2.4 Verifying the Biopsy Guide Line”.
3. Move the cursor onto the image menu, navigate the cursor to [Other] item and press <Set>. Select [Biopsy] in the Other menu to enter the biopsy. Before biopsy guiding, you can preset bracket model, biopsy display and guide line dot type.

Tip:

- If the current probe has no matched bracket; or, the image is frozen and the guide line is hidden before image frozen, then you can't enter Biopsy menu.
  - Before entering Biopsy menu, the system will prompt you “Please verify guidelines before biopsy”.
4. Set [Display] as “On” to display the guide line, select the bracket and guide line according to actual situation. For details, please refer to “8.2.4 Verifying the Biopsy Guide Line”.

5. On the Biopsy menu, click [Verify] to enter the Verify menu to verify the guide line. For details, please refer to “8.2.4 Verifying the Biopsy Guide Line”. After the verification, click [Save] on the menu to save the parameter setting. And then click [Exit] to return to Biopsy menu.

Tip:

- If you switched the probe or needle-guided bracket during the biopsy, please verify the guide line again.
  - When exit the Verify menu without saving the setting, system will confirm with you “Data have changes. Do you want to save the changes?”. Click [OK] to save the setting and return to Biopsy menu.
6. Scan to locate the target. Center the target in the electronic guidezone path.
  7. Direct the needle into the area of interest for specimen.
  8. After extraction of the biopsy sample is completed, gently remove the probe from the body.  
To exit Biopsy menu: press <Esc> key; or, navigate the cursor onto the other menu.
  9. Disassemble the items and properly dispose of these items as required.

**⚠ DANGER** Fail to match the guidezone displayed to the guide may cause the needle to track a path outside the zone.  
It is extremely important that when using the adjustable angle biopsy guides, the angle displayed on the screen matches the angle set on the guide, otherwise the needle will not follow the displayed guidezone which could result in repeated biopsies or patient injury.

## 8.2.3 Needle-guided Bracket Inspection and Installation

### 8.2.3.1 Inspection of the Needle-guided Bracket

Be sure to perform inspections before and after use of the needle-guided bracket. If an abnormality is found on the needle-guided bracket, immediately stop using it and contact MINDRAY Customer Service Department or sales representative.

1. Sterilize the needle-guided bracket before and after use.
2. Confirm that the needle-guided bracket is free of damage, deformation, stripping, malfunction, loose, or missing parts.
3. Confirm that the needle-guided bracket is securely mounted in the correct position.

### 8.2.3.2 Installing the Needle-guided Bracket

#### ■ NGB-001 metal/needle detachable needle-guided bracket

1. Put on the sterile transducer sheath.
2. Hold the transducer by one hand, select the proper needle-guided bracket, and hold it with the other hand. Match the groove of the bracket with the tab of the transducer. Amount the bracket onto the transducer.

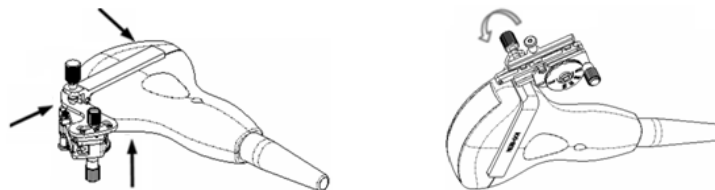

3. Screw the pinch nut of the needle-guided bracket to confirm that the needle-guided bracket is properly installed on the transducer.
4. Adjust the dial scale to the required needle type shift, and then screw the needle fixing nut to lock the dial scale. (To adjust the dial scale you have to loose the needle fixing nut first.)



5. Pull the lock pin and close the V-shaped cover to fix the lock pin in the groove of the needle type adjusting base, so as to install the needle into the guiding hole.

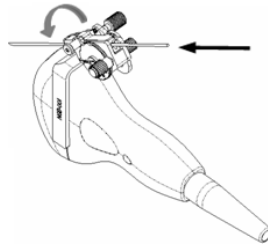

■ NGB-003 metal/needle detachable needle-guided bracket

- (1) Put on the transducer cover.
- (2) Select a proper needle-guided bracket, and match the groove with the tab of the transducer respectively. Mount the bracket onto the transducer.

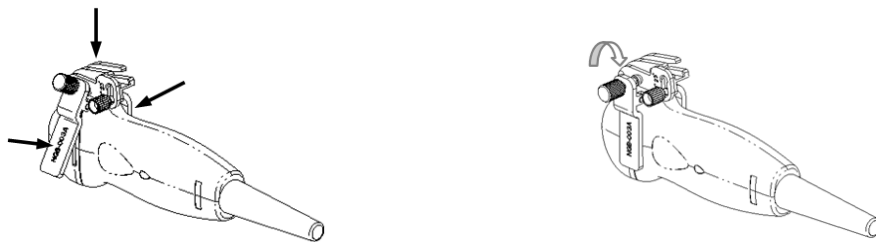

- (3) Screw the pinch nut of the needle-guided bracket to confirm that the needle-guided bracket is properly installed on the transducer.
- (4) Select a proper guiding block and push it into the groove above the angle block.



- (5) Screw the nut of the block to secure the block.
- (6) Insert a biopsy needle with the same specification as that of the guiding block into the hole of the guiding block.

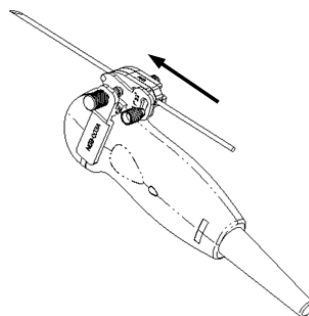

■ NGB-001, NGB-002, NGB-003 and NGB-005 metal/needle un-detachable needle-guided bracket (taking NGB-001 as example)

- (1) Inosculate the locating groove on the clamp with the two raised edges on the transducer head and aligning the locating pit of the clamp to the convex point on the transducer head.
- (2) Turn the grip knob at the tail of the needle-guided bracket tightly.

■ NGB-004 metal/needle un-detachable needle-guided bracket

- (1) Put on the sterile probe sheath.

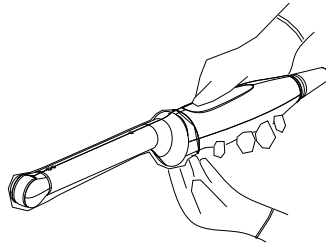

- (2) Open the retaining clamp, align the needle-guided bracket with the probe to locate the locating bulge on the needle guide to the locating grooves on the probe, and then turn the retaining clamp to match it with the probe (see the figure below).

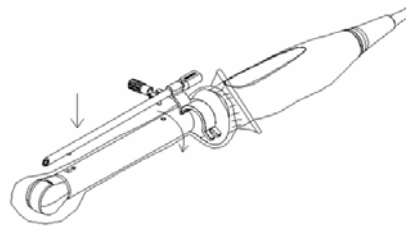

- (3) When the retaining clamp is turned to the right position, the locking nut will lock the retaining clamp and the needle-guided bracket is then mounted to the right position.

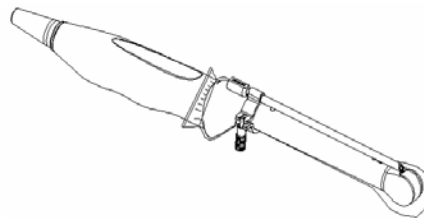

■ NGB-007

Metal/needle detachable needle-guided bracket:

- (1) Put on the sterile transducer sheath.  
(2) Hold the transducer by one hand, select the proper needle-guided bracket, and hold it with the other hand. Match the groove and tab with the tab and groove of the transducer respectively. Amount the bracket onto the transducer.

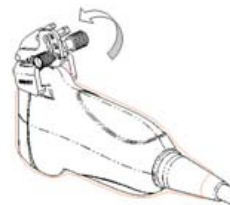
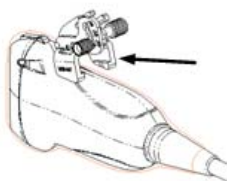

- (3) Screw the pinch nut of the needle-guided bracket to confirm that the needle-guided bracket is properly installed on the transducer.  
(4) Select a proper guiding block and push it into the groove above the angle block, and clamp it tightly.

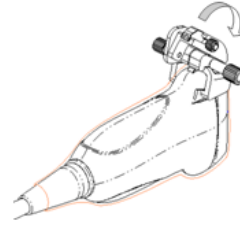
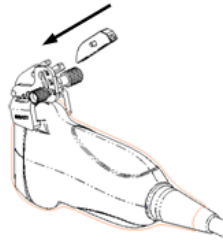

- (5) Screw the nut of the block to secure the block.
- (6) Insert a biopsy needle with the same specification as that of the guiding block into the hole of the guiding block.

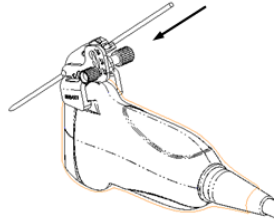

Plastic/needle detachable needle-guided bracket:

- (1) Put on the sterile probe sheath.
- (2) Hold the probe by one hand, select the proper needle-guided bracket, and hold it with the other hand. Align the narrow end tab of the needle-guided bracket with the groove of the probe, then push the needle-guided bracket forward, making the tabs and the grooves of the needle-guided bracket to match with the grooves and tabs of the probe.

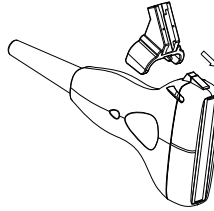

- (3) Check manually to confirm that the needle-guided bracket is securely installed on the probe.
- (4) Select a proper guiding block and push it into the groove above the angle block, and clamp it tightly.

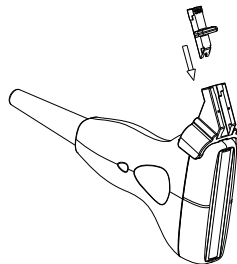

- (5) Insert a biopsy needle with the same specification as that of the guiding block into the hole of the guiding block.

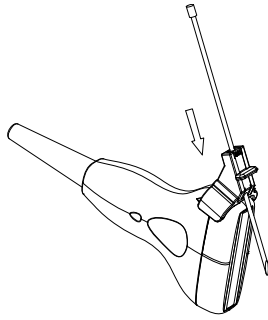

■ NGB-009 metal/needle detachable needle-guided bracket

(1) Put on the transducer cover.

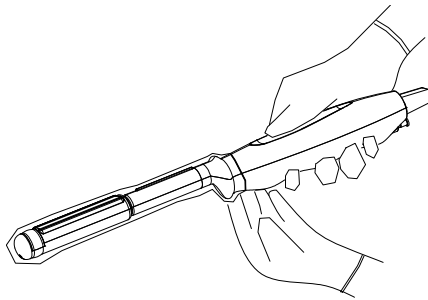

(2) Cover the support of needle-guided bracket on the transducer, making the groove of the needle-guided bracket to match with the tab of the transducer. Set the needle-guided bracket at the desired position, turn tightly the knob of fixing needle-guided bracket to fix the needle-guided bracket.

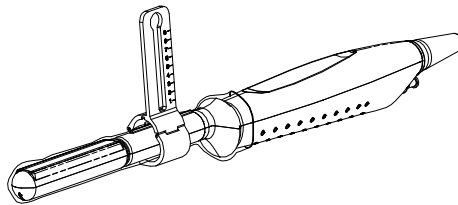

(3) Select a proper guiding block and thread the knob of fixing the guiding block through the hole of installing guiding block, move the guiding block to the desired position, then turn tightly the knob of fixing the guiding block to fix the guiding block on the support of needle-guided bracket.

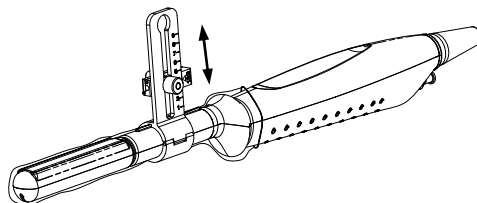

(4) Insert a biopsy needle with the same specification as that of the guiding block into the hole of the guiding block and turn tightly the knob of fixing the needle.

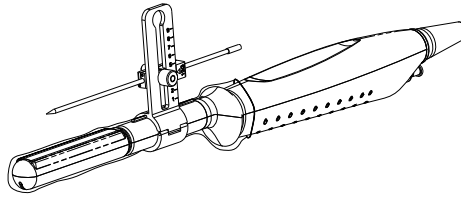

■ NGB-010 metal/needle detachable needle-guided bracket

- (1) Put on the transducer cover.
- (2) Hold the transducer by one hand, select proper needle-guided bracket, and hold it with the other hand, and align the grooves of the needle-guided bracket with the tabs of the transducer, then push the needle-guided bracket forward, making the grooves of the needle-guided bracket to match with the tabs of the transducer. Set the needle-guided bracket at the desired position, turn tightly the knob of fixing needle-guided bracket to fix the needle-guided bracket.

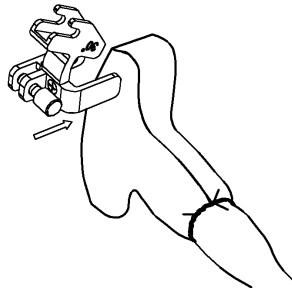

- (3) Check manually to confirm the needle-guided bracket is securely installed on the transducer.
- (4) Select a proper guiding block and push it into the groove above the support of needle-guided bracket, then turn tightly the knob of fixing the guiding block to fix the guiding block on the support of needle-guided bracket.



- (5) Insert a biopsy needle with the same specification as that of the guiding block into the hole of the guiding block.

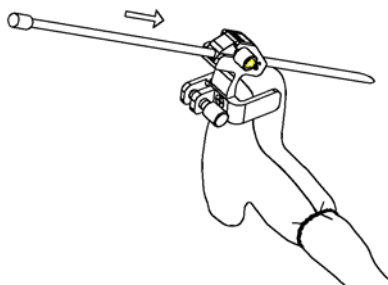

**⚠ CAUTION:** Ensure that all guide parts are seated properly prior to performing a biopsy.

## 8.2.4 Verifying the Biopsy Guide Line

Adjusting the needle mark is necessary before every biopsy procedure.

1. Confirm that the needle-guided bracket has been installed securely in the correct position.
2. Prepare a container filled with sterile water.
3. Place the head of the probe in the sterile water, and get a biopsy needle into the needle guide.
4. When the biopsy needle appears on the image, confirm that the biopsy needle is displayed at almost the same position as the selected needle mark.

**⚠ WARNING:**

1. Prior to each biopsy procedure, be sure to verify the guide line.
2. If the needle is not consistent with the guide line, DO NOT perform the biopsy procedure.

**NOTE:** You can perform guide line verification on a single live B/C image, and all biopsy-irrelevant operations are forbidden.

## 8.2.5 Removing the Needle-guided Bracket

### ■ NGB-001

Metal/needle detachable needle-guided bracket:

1. Pull the lock pin and open up the V-shaped cover to expose the needle.

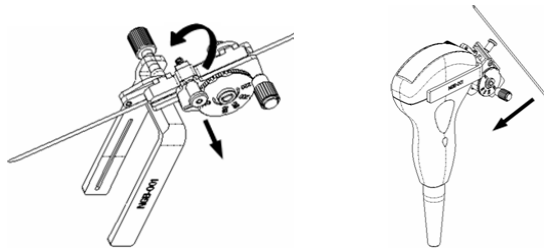

2. Separate the bracket and the transducer from the needle.
3. Screw the pinch nut to release the needle-guided bracket.

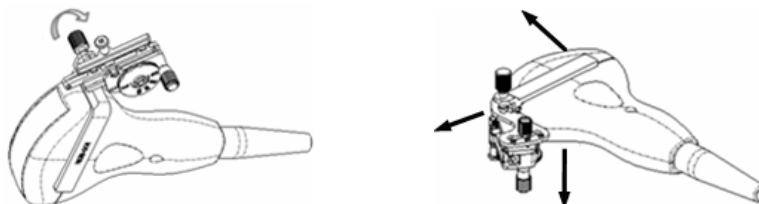

4. Separate the bracket and the transducer.

Metal/needle-undetachable needle-guided bracket:

While holding the transducer and the needle-guided bracket, open the Grip knob of the needle-guided bracket.

- NGB-002 metal/needle un-detachable needle-guided bracket:

While holding the transducer and the needle-guided bracket, open the Grip knob of the needle-guided bracket.

- NGB-003

Metal/needle detachable needle-guided bracket:

- (1) Screw the nut of the guiding block and remove the guiding block slightly along the direction of the needle's tail.



- (2) Separate the residual part of the needle-guide bracket and the transducer from the needle.



- (3) Screw the pinch nut of the bracket, and remove the needle-guided bracket from the transducer.

Metal/needle un-detachable needle-guided bracket:

While holding the transducer and the needle-guided bracket, open the Grip knob of the needle-guided bracket.

- NGB-004 metal/needle un-detachable needle-guided bracket:

Hold the probe in the left hand, unscrew the locking nut with the right hand to open the retaining clamp, and then raise the needle-guided bracket to separate the locating bulge from the locating grooves.

- NGB-005 metal/needle un-detachable needle-guided bracket

Hold the probe and the needle-guided bracket, open the grip knob of the needle-guided bracket.

- NGB-007

Metal/needle detachable needle-guided bracket:

- (1) Screw the nut of the guiding block and remove the guiding block slightly along the direction of the needle's tail.



- (2) Separate the residual part of the needle-guide bracket and the transducer from the needle.
- (3) Screw the pinch nut of the bracket, and remove the needle-guided bracket from the transducer.



Plastic/needle detachable needle-guided bracket:

- (1) Remove the guiding block slightly along the direction of the needle's tail.
- (2) Separate the residual part of the needle-guide bracket and the probe from the needle.
- (3) Remove the support of needle-guided bracket from the probe.

■ NGB-009 metal/needle detachable needle-guided bracket

- (1) Turn on the knob of fixing the needle and separate the needle from the needle-guided bracket.
- (2) Turn on the knob of fixing guiding block and remove the guiding block from the hole of installing guiding block.
- (3) Turn on the knob of fixing needle-guided bracket and remove the needle-guided bracket.

■ NGB-010 metal/needle detachable needle-guided bracket

- (1) Remove the guiding block slightly along the direction of the needle's tail, and separate the residual part of the needle-guide bracket and the transducer from the needle.
- (2) Remove the support of needle-guided bracket from the transducer.

## 8.2.6 Clean and Sterilize the Needle-guided Bracket

### Cleaning

Please follow the instructions in the manual for cleaning.

1. Wear sterile gloves to prevent infection.
2. Wash the needle-guided bracket with water or soap water to remove all the external matters.  
Or, clean the needle-guided bracket with urethane sponge.
3. Wipe off the water on the needle-guided bracket using sterile cloth or gauze after washing it.

### Sterilization

1. Wear sterile gloves to prevent infection.
2. Clean the needle-guided bracket before sterilizing it. MINDRAY recommends the following solution or sterilizing system to sterilize the needle-guided bracket.



3. Follow local regulations when selecting and using the disinfectant.

■ Glutaraldehyde-based sterilant:

Chemical name	Trade name	Procedures
Glutaraldehyde (2.2-2.7%)	Cidex Activated Glutaraldehyde Solution	Please refer to the instructions provided by the manufacturer of the solution for details.  Soak the transducer into the activated solution for 10 hours (20-25°C)

Before safety and performance is affected, plastic bracket NGB-007 can be sterilized by Cidex Activated Glutaraldehyde Solution for at least 233 times (10 hours for one time).

■ Hydrogen Peroxide and Peroxyacetic Acid -based sterilant:

Trade Name	Chemical Name	Procedures
Minnicare® Cold Sterilant	22% Hydrogen Peroxide 4.5% Peroxyacetic Acid	Dilute the sterilant with sterilized purified water (1:20). Immersed time: 11 hours. Temperature: 20°C-25°C. Please refer to the instructions provided by the manufacturer of the solution for details.

Before safety and performance is affected, plastic bracket NGB-007 can be sterilized by Minncare COLD STERILANT for at least 245 times (11 hours for one time).

- Refer to the instructions provided by the chemical manufacturer concerning concentration of the solution, and method of disinfections and dilution. Note that the glutaraldehyde disinfectant solution needs an activating solution.
- Rinse the needle-guided bracket thoroughly with sterile water to remove all chemical residues on it.
- Wipe off the water on the needle-guided bracket with sterile cloth or gauze after rinsing it.

■ STERRAD 100S low-temperature hydrogen peroxide gas plasma sterilization system

Chemical name	Trade name	Procedures
Hydrogen peroxide gas plasma	Hydrogen peroxide vapor	Please refer to the instructions provided by the producer of the solution for details.

- Refer to the instruction of STERRAD 100S sterilizing system provided by the manufacturer for operation instructions and cautions.
- The STERRAD 100S low-temperature hydrogen peroxide gas plasma sterilization system is available for metal needle-guided brackets.

■ High-pressure steam sterilization (only applicable for metal guided-bracket)

Autoclaving (moist heat) 121° C for 20 minutes.

**NOTE:**

1. Repeated sterilization may degrade the safety and performance of the needle-guided bracket.
2. The high-pressure steam/ immersion sterilization do not affect the bracket dual life, and the dual life is affected by the daily application of the bracket. Please check the appearance of the bracket before using.

## 8.2.7 Storage and Transportation

1. Don't use the carrying case for storing the needle-guided bracket. If the carrying case is used for storage, it may become a source of infection.
2. Between examinations, keep the needle-guided bracket in a sterile environment.
3. When the needle-guided bracket is sent to your MINDRAY representative for repair, be sure to disinfect or sterilize it and keep it in the carrying case to prevent infection.
4. Sterilize the carrying case as necessary.
5. Store or transport the needle-guided bracket under the following ambient conditions:
  - Ambient temperature: -20°C to 55°C
  - Relative humidity: 30% to 85% (no condensation)

## 8.2.8 Disposal

Be sure to dispose the needle-guided bracket only after sterilizing it.  
Contact your MINDRAY representative when disposing of this device.

# 9 Preset

---

This chapter introduces how to customize your ultrasonic diagnostic imaging system.

The preset function is designed to configure the parameters of operating the system and maintain user workflow preferences.

- To enter preset: Press <Setup> to open the preset menu.
- To exit preset: Click [Return] in the preset menu to close the preset menu and exit preset.

<b>⚠ CAUTION:</b>	<b>When the setup data is changed, be sure to save the preferences according to the methods described in this chapter. Mindray is not responsible for the loss of the setup data.</b>
-------------------	---

- |              |   |
|--------------|---|
| <b>Note:</b> | <ol style="list-style-type: none"><li>1. The Preset parameters take effect only after returning from Preset following the above operations.</li><li>2. Entering and returning from Preset during an exam will clear the measurement data.</li></ol> |
|--------------|---|

The following table describes the contents of the items in the preset menu.

Items	Contents or Functions
System Preset	Region, General, Image Preset, Meas Param, OB, Key Config and Option.
Exam Preset	To select exam preset or configure exam preset.
Image Config	To configure the default image parameters of each exam mode.
Measure Preset	To configure the measure packages.
Comment Preset	To configure the comment library for different exam modes.
DICOM	To configure parameters related to DICOM applications. This item is only available for systems configured with DICOM software.
Manage Settings	To manage the preset data.
Maintenance	To maintain the system.
About	Click to check the system information.
Return	Save changes and exit preset.

## 9.1 Basic Operations

The basic operations of controls in Preset are as follows:

- Text box: Input text with the keyboard.
- Radio Button: Click the button to select an item. At least one and only can be selected.
- Check box: Click the check box to select it or deselect it. Selecting plural boxes and selecting none are both allowed.
- Drop-down list: Click the arrow beside the list to select an item.

## 9.2 System Preset

System Preset contains the following sub items:

Item	Descriptions
Region	To configure the name of hospital, language, time zone, date and time, etc.
General	To configure the contents displayed in the patient information area, system dormancy, file saving and comments, etc.
Image Preset	To configure the default image parameters when system is reset and image control, etc.
Meas Param	To configure the measure ruler, measure result, exam report and units of measure results, etc.
OB	To configure the formula for Fetal Gestational Age, Fetal Growth and Fetal Weight, etc. Refer to [Advanced Volume] for details.
Key Config	To configure the function of some buttons in control panel and parameters related to the control panel.
Peripheral	To configure parameters related to peripherals.
Option	To configure the options.

### 9.2.1 Region

Item	Type	Description
Hospital	Text box	Input the name of hospital here.
Language	Drop-down list	To select the language of system.
Time Zone	Drop-down list	To select the time zone.
Time Format	Radio button	To select the format of time.
Date Format	Radio button	To select the format of date.
System Date	Number	Move the cursor to the corresponding field, and then press <Set> to increase the value or press <Back> to decrease the value.
System Time	Number	

## 9.2.2 General

Sub-page	Item	Type	Description
Patient Info	Info displays in image banner	Check box	To select the items to be displayed in the patient information area.
	H&W Unit	Radio button	To select the unit: Metric/English.
	Surface Formula	Radio button	To select the formula of surface area: Orient/West.
Image Format	JPG Compress	Drop-down list	To select the compression ratio of JPG format: Low/Middle/High.
	Single Frame Format	Drop-down list	To select the format of single-frame files: FRM/JPG/BMP/DCM (DCM is available only when DICOM is installed).
	Multi Frame Format	Drop-down list	To select the format of multi-frame files: CIN/AVI/DCM (DCM is available only when DICOM is installed).
System Dormancy	Switch of dormancy	Check box	To turn On/Off dormancy.
	Wait Time	Number	This item can be configured after dormancy is turn on. Click “▲” to increase the value and click “▼” to decrease the value. The range is: 5-60 minutes and the step length is 1 minute.
ABC	Font Size	Radio button	To set the size of comments: Small/Middle/Big.
	Arrow Size	Radio button	To set the size of arrows: Small/Middle/Big.
Video export format	Video export format	Radio button	To select the format of video output: PAL/NTSC.
	Paper Size	Drop-down list	To set the paper size of graph/text printer: A4, B5, Letter, Unknown.
/	Load Factory	Button	Reset all parameters to factory default in this page.

## 9.2.3 Image Preset

Sub-page	Item	Type	Description
Reset Config	Probe	Drop-down list	To set the model of default transducer displayed when no transducer is connected.
	Exam Mode	Drop-down list	To set the default exam mode after system starts.
	Reload Preset on New Patient	Check box	To set whether to adopt the default image parameters or not when beginning a new exam: Checked (to adopt default image parameters)/Unchecked (to continue with current image parameters)

Sub-page	Item	Type	Description
	Frozen when Measurement	Radio button	To set the status when frozen in measurement mode: Cine (to switch to cine review mode)/Measure (to keep measuring)
Image Control	Lithotrity Enable	Check box	Checked (enables lithotrity)/Unchecked (disables lithotrity)
	Image Merge	Check box	Checked (enables image merging)/Unchecked (disables image merging)
	B/M Display Mode	Radio button	To set the arrangement of B/M images in B+M mode: Up/Down, Left/Right.
	Display Thumbnail when Zoom	Check box	Checked (to display thumbnail when zooming)/Unchecked (to hide thumbnail when zooming)
/	Load Factory	Button	Reset all parameters in this page to factory default.

## 9.2.4 Meas Param

Sub-page	Item	Type	Description
Measure Ruler	Cursor Type	Drop-down list	To select the cursor type: Symbol (marks different calipers with symbols), Number (marks different calipers with numbers).
	Mark Size	Drop-down list	To select the size of mark: Large, Middle and Small.
	Heart Beat	Drop-down list	To set the number of cardiac cycles in HR measurement (the number of cardiac cycles selected when measuring should match the preset number here): 1~8.
	Cursor Line Display	Check box	To set whether to display the dotted line between ends of calipers or not when measuring: On/Off.
	Ellipse Cross Line Display	Check box	To set whether to display the dotted lines indicating the major axis and minor axis or not in ellipse measurement: On/Off.
Measure Result	Result Background	Drop-down list	To set the background color of the result window: Transparent, Grey.
	Result Show	Drop-down list	To set the contents displayed in result window: All, Current.
	SD Display	Check box	To set whether to display SD (standard deviation) in the result window.
	EDD Display	Check box	To set whether to display EDD (Estimated Delivery Date) in the result window.
	Results are cleared if deleting caliper	Check box	To set whether to clear the measurement results when deleting the calipers.

Sub-page	Item	Type	Description
Exam Report	Trend Format	Drop-down list	To set the format of growth graphs: 1*1, 2*1 and 2*2.
Unit	Distance, Area, Volume, Time, Velocity, Slope, Acceleration	Drop-down list	To select the unit of the results

## 9.2.5 OB

To configure the formulas of Fetal Gestational Age, Fetal Growth and Fetal Weight. Refer to [Advanced Volume] for details.

## 9.2.6 Key Config

To define the functions of some keys in control panel or buttons of the footswitch and parameters of control panel.

1. Select a page in "Key", and then select the key to be configured in the list.
2. Select a page in "Function", and then click a function to assign it to the selected key.

Panel	Panel	Function	Available Functions
Key	Print, Save1, Save2, F1, F2, F3, F4, F5; Gain (the function when Gain is pressed)	Output	Analog B/W Video Print Save Single frame Image to Local Disk Save Single frame Image to USB Disk Save Multi-frame Image to Local Disk Save Multi-frame Image USB Disk
		Exam Mode	To switch to the corresponding exam mode.
		Application	Set Home: Sets current location as home in comment mode. Home: Moves cursor to home in comment mode. Report: Opens/closes report. iVision: Opens iVision. iStation: Opens/closes iStation.
		Other	Biopsy Line Display, M-Mark Display, Rotation, 4B, Clear, Exit: Closes the dialog box without saving changes. TSI, None
Footswitch	Left, Right	Output	Same as those of "Panel".
		Exam Mode	Same as those of "Panel".
		Application	Same as those of "Panel".
		Other	Biopsy Line Display, M-Mark Display, Rotation, 4B, Clear, Exit, TSI, B, M, Dual, Freeze, Measure, Comment, Body Mark, Menu, Exam, None

Keyboard preset:

Item	Type	Description
Key Lightness	Drop-down list	To set the brightness of keyboard back light: Low/High/None
Key Volume	Drop-down list	To set the volume of keyboard sound: Low/High/None
Trackball Speed	Drop-down list	To set the speed of cursor when rolling the track ball: Slow/Mean/Fast

### Preset of Key Config

- Key
  - Print            Analog B/W Video Print
  - Save1           Save Single frame Image to Local Disk
  - Save2           Save Single frame Image to USB Disk
  - F1                None
  - F2                Report
- Footswitch
  - Left             Analog B/W Video Print
  - Right            Freeze

## 9.2.7 Option

Select an option in the list, click [Install] to install it or click [Uninstall] to un install it.

## 9.3 Exam Preset

To configure the related parameters of each exam mode.

### 9.3.1 Exam Selection

“Exam Selection” is used to select available exam modes for a transducer.

1. Select the model of transducer in the “Probe” drop-down list.
2. To select exam modes for the transducer:
  - [>]: Select an exam mode in “Exam Library”, and click [>] to add it to “Exam Selected”;
  - [>>]: Click [>>] to add all exam modes in the “Exam Library” to “Exam Selected”;
  - [<]: Select an exam mode in “Exam Selected”, and click [<] to delete it;
  - Sort: Select an exam mode in “Exam Selected”, and click [Move Up] or [Move Down] to move it up and down. The sequence here is the same as that in the “Exam Mode” menu.

### 9.3.2 Exam Config

- To select the applied part of exam modes: Click the cell corresponding to “Application” of each exam mode and select the applied part in the drop-down list.
- To copy parameters of an exam mode to another exam mode
  1. Select a source exam mode in the exam modes list.
  2. Click [Copy] to copy the parameters of the source exam mode.



3. Select a target exam mode.
  4. Click [Paste] to paste the parameters to the target exam mode.
- To rename an exam mode
    1. Select an exam mode in the exam modes list.
    2. Click [Rename] to open the “Rename” dialog box.
    3. Input the name of new exam mode.
    4. Click [OK] to confirm or click [Cancel] to cancel.
  - To export parameters of an exam mode
    1. Select an exam mode in the exam modes list.
    2. Click [Export] to open the “Export Data” dialog box.
    3. Select the path of the exported data and name the data.
    4. Click [OK] to confirm or click [Cancel] to cancel.
  - To load parameters of an exam mode
    1. Click [Load] to open the “Load Data” dialog box.
    2. Select the data to be imported.
    3. Click [OK] to confirm or click [Cancel] to cancel.
  - Export All
    1. Click [Export All] to open the “Export Data” dialog box.
    2. Select a disk.
    3. Click [OK] to confirm or click [Cancel] to cancel.
  - Others
 

Select an exam mode, and click [Measure Preset], [Comment Preset] or [Image Preset] to configure the parameters of the selected exam mode. Refer to relevant chapters for details.

## 9.4 Image Preset

“Image Preset” is used to configure the parameters corresponding to exam modes, image modes and transducers. For detailed information about the parameters, please refer to “4 Optimizing the Image”.

1. Select an exam mode.
2. Select an image mode.
3. Select a transducer.
4. Configure the image parameters according to the following tables.

- B/THI

Item	Type	Description
A.Power	Drop-down list	To set the default acoustic power.
TSI	Drop-down list	To set the default TSI.
B Map/THI Map	Button	To configure the B Map/THI Map. Refer to the following segments for detailed operations.
Depth	Drop-down list	To set the default depth.

Item	Type	Description
THI	Check box	Checked/Unchecked: For transducers that support harmonic, you can set harmonic as default frequency when this item is checked.
Frequency	Drop-down list	To set the default frequency.
Scan Angle	Drop-down list	To set the default scan angle: 0, 1, 2, 3.
F.Position	Drop-down list	To set the default focus position.
Focus Number	Drop-down list	To set the default number of focuses.
Gain	Drop-down list	To set the default gain.
THI Gain	Drop-down list	To set the default THI gain. This item is available for transducers that support harmonic only.
Line Density	Drop-down list	To set the default scanning density: Hi Frm Rate, Hi Density 1 and Hi Density 2.
L/R Flip	Radio button	To set the default horizontal flipping mode: Left, Right.
U/D Flip	Radio button	To set the default vertical flipping mode: Up, Down.
Rotation	Drop-down list	To set whether to rotate the image or not: 0, 90, 180, 270.
B IP	Drop-down list	To set the default B IP: 1~8.
THI IP	Drop-down list	To set the default THI IP: 1~8. This item is available for transducers that support harmonic only.
B IP/THI IP	Button	To configure the parameters of B IP/THI IP. Refer to the following segments for detailed operations. The THI IP is available for transducers that support harmonic only.

■ M

Item	Type	Description
Speed	Drop-down list	To set the default M scanning speed.
M Map	Button	To configure the M Map. Refer to the following segments for detailed operations.
M Gain	Drop-down list	To set the default M Gain.
M Map	Drop-down list	To set the default M Map.
Edge Enhance	Drop-down list	To set the default parameter of Edge Enhance.
M IP	Drop-down list	To set the default M IP.
M IP	Button	To configure the M IP. Refer to the following segments for detailed operations.

■ B/THI Map

1. Click [B Map]/[THI Map] to open the “Effect” dialog box.
2. Select the grey map to be configured.
3. Configure the “Grey Curve”, “Grey Rejection” and “γ” (please refer to “4.2.13 B/M Post Process” for details), or click “Record Current” to record the current parameters as preset.

4. Click [OK] to confirm or click [Cancel] to cancel.
- B/THI IP/M IP
    1. Click [B IP]/[THI IP] to open the “B IP”/“THI IP”/“M IP” dialog box.
    2. Configure the parameters of “Dyn Rng (Dynamic Range)”, “Img Enhance (Image Enhance)” and “Frame Avg (Frame Average)” (for B/THI IP) or “Dyn Rng (Dynamic Range)” and “M Soften” (for M IP) in the corresponding drop-down list.
    3. Click [OK] to confirm or click [Cancel] to cancel.
  - Record Current: Record the current parameters as preset.
  - Load Factory: Restore all parameters in this page to factory default.

## 9.5 Measure Preset

### 9.5.1 Measure

This system provides a measurement library, including Measurement, Calculate and Study items of General, Abdomen, Gynecology, Cardiac, Vascular, Urology, Small Parts, ORTH and Obstetric.

- To configure the measurement package
  1. Select an exam mode.
  2. Input the name of the measurement package. To manage the measurement package, click [Advanced].
  3. Select a scan mode. If “Use same menu for all scan mode” is selected, you need not to select the scanning mode.
  4. Select the type of the measurement item.
  5. Add/delete items for measurement package:
    - [>]: Select an item in “Available Items”, and click [>] to add it to “Selected Items”;
    - [>>]: Click [>>] to add all items in the “Available Items” to the “Selected Items”;
    - [<]: Select an item in “Selected Items”, and click [<] to delete it;
    - [<<]: Click [<<] to delete all items in “Selected Items”;
    - Sort: Select an item in “Selected Items”, and then click [Move Up] or [Move Down] to move it up/down.
    - [Default]: Select an item in “Selected Items”, and click [Default] to set it as default measurement items.
  6. To set the measure sequence of the measurement package:
    - None: After the measurement, the cursor returns to the measurement menu;
    - Repeat: After the measurement, the system automatically activates the current item again;
    - Next: After the measurement, the system automatically activates the next item in the menu.
- To manage the measurement package: Click [Advanced] to manage the measurement package.
  - [>]: Select a package in “Available Items”, and click [>] to add it to “Selected Items”;
  - [>>]: Click [>>] to add all packages in the “Available Items” to the “Selected Items”;
  - [<]: Select a package in “Selected Items”, and click [<] to delete it;
  - [<<]: Click [<<] to delete all packages in “Selected Items”;
  - Sort: Select a package in “Selected Items”, and then click [Move Up] or [Move Down] to move it up/down.

- [Default]: Select a package in “Selected Items”, and then click [Default] to set it as the default measurement package of current exam mode;
- [New]: Click [New] to create a new package;
- [Delete]: Select a package in “Available Items”, and click [Delete] to delete it.

## 9.6 Comment Preset

“Comment Preset” is used to configure the comment library for each exam mode.

- To configure the comment libraries
  1. Select an exam mode in the “Exam Mode” drop-down list.
  2. Input the name of the comment library.
  3. To add/delete comment words for this library:
    - [>]: Select a word in “Available Items”, and click [>] to add it to “Selected Items”;
    - [>>]: Click [>>] to add all words in the “Available Items” to the “Selected Items”;
    - [<]: Select a word in “Selected Items”, and click [<] to delete it;
    - [<<]: Click [<<] to delete all words in “Selected Items”;
    - Sort: Select a word in “Selected Items”, and then click [Move Up] or [Move Down] to move it up/down.
- To edit a comment
  1. Select an item in “Selected Items”, and the item turns to editing mode.
  2. Edit the comment.
  3. To add the edited comment to comment library: Click [<] to move the item to “Available Items”.
- To add a new comment
  1. Click the last row of “Selected Items”, and the row turns to editing mode.
  2. Input a new comment.
  3. To add the edited comment to comment library: Click [<] to move the item to “Available Items”.
- [Delete]: Select a user-defined comment in “Available Items”, and click [Delete] to delete it.
- [Load Factory]: Restore the comment library with factory data.

## 9.7 DICOM

This item is only available for systems configured with DICOM.

Before configuring DICOM, please read the DICOM CONFORMANCE STATEMENT of this system and SCPs such as PACS, RIS or HIS to make sure the SCU service is supported by the SCPs.

- System Name: It is the same as “AE Title”.
- Institution Name: Input the name of the institution using this system.
- Network Information

	AE Title	Host Name	IP Address	Port	Alias	Packet Size
Local	It must be consistent with that of the server. Indispensable	Customized Indispensable	Assign an available IP address to the system. Indispensable	It must be consistent with that of the server. Indispensable	Customized Dispensable	Indispensable
Server1	It must be consistent with that of the server. Indispensable	Customized Indispensable	Input the IP address of the server. Indispensable	It must be consistent with that of the server. Indispensable	Customized Dispensable	Indispensable
Server2	Dispensable. Refer to Server1 for details.					
Server3	Dispensable. Refer to Server1 for details.					

The range of packet size is: 4096~65536.

The range of port is: 1~65535.

- [Verify]: After configuring the network information, exit “DICOM Preset” and click [Return] to validate the configurations. Then enter [Preset]→[DICOM Preset] again, and click [Verify] to verify the configuration.
- Local
  - Subnet Mask: Input the Subnet Mask according to practical situation.
  - Gateway: Input the IP address of the gateway according to practical situation.
- Server: To set the default server for different services, select a server in the drop-down list.
  - Current Storage Server
  - Current Worklist Server
  - Current Print Server
- Print Parameter

Item		
Copies	Drop-down list/Text box	Select or input the copies of files to be printed.
Film Size	Drop-down list	8INX10IN, 8_5INX10IN, 10IN×12IN, 10IN×14IN, 11INX14IN, 11INX17IN, 14INX14IN, 14INX17IN, 24cm×24cm, 24cm×30cm, A4, A3
Medium Type	Drop-down list	Paper, Clear Film, Blue Film
Trim	Drop-down list	Yes, No

Item		
Settings	Drop-down list	Monochrome2
Min Density	Text box	Input a number representing minimum density.
Max Density	Text box	Input a number representing maximum density.
Priority	Drop-down list	High, Med, Low
Film Orientation	Drop-down list	LANDSCAPE, PROCESSOR
Film Destination	Drop-down list	MAGAZINE/ PROCESSOR
Display Format	Drop-down list	STANDARD\1,1; STANDARD\2,2; STANDARD\2,3; STANDARD\3,3; STANDARD\3,4; STANDARD\3,5; STANDARD\4,3; STANDARD\4,4; STANDARD\4,5; STANDARD\5,6;
Magnification Type	Drop-down list	Input type of magnification: REPLICATE/ BILINEAR/ CUBIC/ NONE
Configuration Info	Text box	Specified image quality control information of printers.
OK	Button	Save and exit.
Cancel	Button	Cancel and exit.

## 9.8 Manage Settings

- Export
  1. Select the items to be exported and click [Export].
  2. Select the path.
  3. Click [OK] to export or click [Cancel] to cancel.
- Import
  - [Restore Factory]: Select a category and click [Restore Factory] to reset it.
  - Import
    1. Select the items to be imported and click [Import].
    2. Select the path and the preset data to be imported (\*.DTA).
    3. Click [OK] to import or click [Cancel] to cancel.
- [Export All]: To export all the items.
- [Import All]: To import all the items.
- [Restore Factory]: To restore all items to factory default.
- [Exit]: To exit.

## 9.9 Maintenance

The [Maintenance] is for updating of system software or other special requirements. Contact your service representative if necessary.

# 10 Battery

---



## **WARNING:**

1. **DO NOT** install or detach the battery ad arbitrium  
The batteries have protective mechanism and circuit.  
**DO NOT** disassemble or alter the battery.
2. **DO NOT** short-circuit the batteries by directly connecting the negative terminals with metal objects.
3. **DO NOT** heat the battery or discard it in a fire.
4. **Keep** the batteries away from fire and other heat sources.
5. **DO NOT** immerse the batteries in water or allow them to get wet.
6. **DO NOT** charge the batteries near a heat source or in direct sunlight.
7. **DO NOT** pierce the batteries with a sharp object, hit or step on them.
8. **DO NOT** use the batteries mixed with other battery models.
9. **DO NOT** put the batteries into a microwave oven or pressurized container.
10. **If** the batteries emit an odor or heat, are deformed or discolored, or in a way appear abnormal during use, charging or storage, immediately remove them and stop using them.

## 10.1 Overview

The battery charges when the system is connected to the AC power supply.

- Generally, if the system is turned off, a completely discharged battery will fully charge in less than 3 hours; or generally a battery has been charged for 2 hours, it can restore the quality of electric charge to above 95%.

- NOTE:**
1. It is recommended to charge the batteries when the system is turned off, thus you can quickly charge the battery and save time.
  2. Power off the system if you will not use the system for a long period of time (including storage/ transportation condition), and you should not allow the system in standby status, otherwise the batteries will be out of power and permanently damaged.

When the external power supply is not connected, a lithium-ion battery will provide the power.

- NOTE:**
1. Only use the specified batteries.

2. If there is only one battery in the system, it cannot supply power and cannot be charged.

## 10.2 Precautions

1. Before using the battery, carefully read the description in the label on the surface of the battery.
2. When you use the battery at the first time and find that it is dirty or emit an odor, do not use it.
3. Do not expose the battery to heat sources or high pressure.
4. Do not leave the battery in direct sunlight.
5. Store the battery out of the reach of children. Store the battery out of the reach of children.
6. The battery is designed to be charged only in this system; charge the battery only when the ambient temperature is between 0 and 40 °C.
7. When the battery is out of power, please charge it immediately.
8. When the battery will not be used for 10 days or over, take it out of the system and store it with caution. DO NOT wrap it with conductive material; store it in shady, cool and dry place.
9. Do not knock the battery.

## 10.3 Installing and Removing the Batteries



### **WARNING:**

**Turn off the system and disconnect the adapter from the main unit before installing or removing batteries. DO NOT install or remove batteries when the system is turned on or the system is turned off but the adapter is connected with the system.**

The battery is put in the battery bays at the back side of the system. You can install or remove it when the system is turned off and the power cord is disconnected from the main unit.

#### ■ To install the battery:

1. Turn off the unit and detach the power cord from the main unit.
2. You can see a battery bay at the back of the system. (Note that the battery shall be put in correct direction). Put the battery into the bay and push to the right side until it's tightly locked.
3. Close the battery cover.

#### ■ To remove the battery:

1. Turn off the unit and detach the power cord from the main unit.
2. Open the battery cover.
3. Push the battery to left until it's released.
4. Take out the battery from the bay.

## 10.4 Battery Status Indicator

The battery status indicator is located in the lower right corner of the screen, indicating the battery capacity.

When the power capacity is not enough, the system will pop up a prompt:

Warning! Battery is out of power! Please connect to power supply or system will be shut down in one minute. Connect the power supply to afford normal work.



## 10.5 One Full Discharge / Charge Cycle

If the battery has not been used for over 2 months, you are recommended to perform one full discharge / charge cycle. It is also recommended that the battery is stored in the shady and cool area with FCC (full current capacity).

### ■ One Full Discharge / Charge Cycle:

1. Full discharge of the battery to let the system automatically shut down.
2. Charge the system to 100% FCC (full current capacity).
3. Discharge of the system for complete shutdown.

## 10.6 Checking Battery Performance

The battery performance may be degraded over time, so you need to check the battery performance periodically. The checking procedures are shown as follows:

1. Stop the ultrasound exam.
2. Connect the system to the AC power supply to charge the batteries until current capacity is full.
3. Disconnect the system from the AC power supply to power the system by the batteries until the system automatically shuts down.
4. The powering time of the batteries indicates the battery performance.

If the powering time of the battery is much shorter than that specified in the Specification Manual, you may replace the battery or contact the service personnel.

## 10.7 Battery Disposal

You need to dispose of the battery when it is damaged, severely degraded or used for 3 years.

<b>NOTE:</b> You should observe the local regulations when disposing of the battery.
--



# 11 Cleaning and Maintaining the System

---

This chapter introduces how to clean and maintain the system.

- ⚠ WARNING:**
1. Only an authorized Mindray service engineer can perform maintenance not specified in this operator's manual.
  2. For the sake of the system performance and safety, you should perform periodical checks for the system.

## 11.1 Daily Maintenance

### 11.1.1 Cleaning the System

- ⚠ WARNING:** Before cleaning the system, be sure to turn off the power and disconnect the power cord from the outlet. If you clean the system while the power is On, it may result in electric shock.

- ⚠ CAUTION:**
1. Do not spill water or other liquid into the system while you perform the cleaning. Otherwise it may result in malfunction or electric shock.
  2. When you want to clean transducer connectors and TGC sliders, contact Mindray Customer Service Department or sales representative. Cleaning it yourself may result in malfunction or degradation of the performance.

■ **Cleaning the transducer**

Please refer to the operator's manual of the corresponding transducer to perform cleaning and disinfection.

■ **Cleaning the transducer cable**

- Use soft dry cloth to wipe off stains from the transducer cable.
- If it is difficult to clean the stains thoroughly, use soft cloth dipped with mild detergent, and then let the cable air dry.

■ **Cleaning the monitor**

Using a soft cloth, apply a glass cleaner directly to the cloth and wipe down the monitor to remove finger marks, dust and smudges. Allow the monitor to air-dry.

■ **Cleaning the control panel, cover and bracket**

Use dry soft cloth to clean the surface of the system. If the system is dirty, moisten the soft cloth with a mild or neutral detergent and wipe off any stains. Use dry soft cloth to remove any moisture and allow all hard surfaces to completely air-dry.

<b>NOTE:</b>	<ol style="list-style-type: none"> <li>1. Do not use hydrocarbon glass cleaner or cleaner for OA (Office Automation) equipment to clean the monitor. These substances may cause deterioration of the monitor.</li> <li>2. Keyboard on the control panel should be cleaned periodically, otherwise, keys maybe blocked by dirt and buzzer dings, keys don't work.</li> </ol>
--------------	---

### 11.1.2 Backup of Data

For systems configured with hard disk, back up the data in hard disk periodically to avoid data corruption or loss.

## 11.2 Maintenance Checks by Service Engineer

Type	Items
Cleaning	Interior of the system Peripherals
Electric safety	Ground leakage current Enclosure leakage current Patient leakage current Patient leakage current (110% supply voltage on applied part)
Mechanical safety	Monitor mounting mechanism Control panel Mounting mechanism for the peripheral devices Check other mechanical structures Check the transducer appearance
Image recording	Images in each mode Image recording by using the standard transducer

### 11.3 Consumables and Periodic Part Replacement

This system contains some consumables and parts requiring periodic replacement. Before replacing them, please contact Mindray Customer Service Department or sales representative for instructions.

### 11.4 Troubleshooting

To ensure proper system operation and function, it is recommended that a maintenance and inspection plan be established to periodically check the safety of the system. If any system malfunction is experienced, contact Mindray Customer Service Department or sales representative. If any persistent system malfunction is experienced, please refer to the following table below. If the failure cannot be eliminated, please contact Mindray Customer Service Department or sales representative.

No.	Malfunction	Potential Causes	Corrective Measures
1	After the power supply is turned on, the power indicator does not light on.	Abnormal power system or incorrect connection of the power cord.	Verify that the plug has not become loosened or dislodged from the back of the system.
2	When the power indicator of the monitor is on and image is blank.	The interval between turnoff and restart is too short – wait minimum 20 seconds.	Turn off the system and wait minimum 1 minute, then restart the system.
		The monitor brightness or contrast may be improperly set.	Adjust the monitor brightness and contrast back to factory defaults.
3	The monitor displays the characters but no images.	The transmission power, overall gain or TGC controls are improperly set.	Adjust the transmission power, gain or TGC control.
		Verify that a transducer is connected and / or fully connected.	Ensure proper transducer connection.
		The image is frozen.	Unfreeze the image.
4	The image quality has degraded	The exam type is not correct.	Select an appropriate exam type.
		The settings of the image post processing are not correct.	Adjust the settings of the image via post processing or reset the post processing to the default values.
		The image presets are appropriate	Reset the factory default setups.
5	The display of image is abnormal. System error messages are displayed all the time. Operations cannot be executed.	/	Restart the System
6	The button is responseless with the system buzzing	Button blocked by too much dirt	Check the control panel for the button being blocked and press it several times to release it.
			Clean the button



# 12 Acoustic Output

---

This section of the operator's manual applies to the overall system including the main unit, transducers, accessories and peripherals. This section contains important safety information for operators of the device, pertaining to acoustic output and how to control patient exposure through use of the ALARA (as low as reasonably achievable) principle.

Read this information carefully before using the system.

## 12.1 Concerns with Bioeffects

Diagnostic ultrasound is recognized as being safe. In fact, there have been no reports of injuries to patients caused by diagnostic ultrasound.

It cannot be stated categorically that ultrasound is 100% safe. Studies have revealed that ultrasound with extremely high intensity is harmful to body tissues.

Diagnostic ultrasound technology has made a great leap forward during the last several years. This rapid advance has generated concerns about the potential risk of bioeffects when new applications or diagnostic technologies become available.

## 12.2 Prudent Use Statement

Although there are no confirmed biological effects on patients caused by exposures from present diagnostic ultrasound instruments, the possibility exists that such biological effects may be identified in the future. Thus ultrasound should be used in a prudent manner to provide medical benefit to the patient. High exposure levels and long exposure times should be avoided while acquiring necessary clinical information.

## 12.3 ALARA Principle (As Low As Reasonably Achievable)

It is required to practice ALARA when using ultrasound energy. Practicing ALARA ensures that the total energy level is controlled below a low enough level at which bioeffects are not generated while diagnostic information is being accumulated. The total energy is controlled by output intensity and total radiation time. The output intensity necessary for examinations differs depending on the patient and the clinical case.

Not all examinations can be performed with an extremely low level of acoustic energy. Controlling the acoustic level at an extremely low level leads to low-quality images or insufficient Doppler signals, adversely affecting the reliability of the diagnosis. However, increasing the acoustic power more than necessary does not always contribute to an increase in quality of information required for diagnosis, rather increasing the risk of generating bioeffects.

Users must take responsibility for the safety of patients and utilize ultrasound deliberately. Deliberate use of ultrasound means that output power of ultrasound must be selected based on ALARA.

Additional information regarding the concept of ALARA and the possible bioeffects of Ultrasound is available in a document from the AIUM (American Institute of Ultrasound Medicine) title "Medical Ultrasound Safety".

## 12.4 Derated Ultrasonic Output Parameters

In order to determine the relevant Ultrasonic Output Parameters, a method is used which allows for the comparison of ultrasound systems which operate at different frequencies and are focused at different depths. This approach, called "derating" or "attenuating", adjusts the acoustic output as measured in a water tank to account for the effect of ultrasound propagation through tissue. By convention, a specific average intensity attenuation value is used, which corresponds to a loss of 0.3 dB/cm/MHz. That is, the intensity of ultrasound will be reduced by 0.3 dB/MHz for every centimeter of travel from the transducer. This can be expressed by the following equation:

$$I_{\text{atten}} = I_{\text{water}} \times 10^{(-0.3/10 \times f_c \times z)}$$

Where  $I_{\text{atten}}$  is the attenuated intensity,  $I_{\text{water}}$  is the intensity measured in a water tank (at distance  $z$ ),  $f_c$  is the center frequency of the ultrasound wave (as measured in water), and  $z$  is the distance from the transducer. The equation for attenuating pressure values is similar except that the attenuation coefficient is 0.15 dB/cm/MHz, or one-half the intensity coefficient. The intensity coefficient is double the pressure coefficient because intensity is proportional to the square of pressure.

Although the attenuation coefficient chosen, 0.3 dB/cm/MHz, is significantly lower than any specific solid tissue in the body, this value was chosen to account for fetal examinations. In early trimester ultrasound fetal examinations, there may be a significant fluid path between the transducer and the fetus, and the attenuation of fluid is very small. Therefore the attenuation coefficient was lowered to account for this case.

It was verified that the MI and TI values didn't exceed 1.0 in each exam mode.

## 12.5 Measurement Uncertainty

Total Uncertainty for Mechanical Index	16.4 %		
	Non-scan Mode	Scan-Mode	Combined-Mode
Total Uncertainty for TIS	32.9%	5.1%	32.9% or 5.1% ( $A_{\text{aprt}} > 1$ )
			33.4% ( $A_{\text{aprt}} \leq 1$ )
Total Uncertainty for TIB	32.9%	5.1%	32.9% or 5.1%
Total Uncertainty for TIC	32.9%	5.1%	33.4%

## 12.6 Parameters Affecting Acoustic Power

Acoustic Power is affected by transmission conditions (focus, drive frequency, voltage applied to piezoelectric elements, etc.), scan conditions, and settings of the control panel, and preset menu.



## 12.7 Acoustic Power Setting

- Adjusting Acoustic Power

You can adjust the acoustic power from the image menu, and its value is displayed in the parameters area at the top of the screen.

Acoustic power can be set in the range from 0 to 15, where 0 represents minimum acoustic power and 15 represents maximum acoustic power.

When the image is frozen, the system stops transmitting acoustic power.

- Default setting of acoustic power

Selection of diagnostic applications is the most important factor for controlling ultrasound output. The permissible level of intensity of ultrasound differs depending on the region of interest. For fetal examinations, in particular, much care must be exercised.

In this system, imaging setups can be created using the ultrasound output set by you. At this time, the default function is disabled. It is the user's responsibility for any change to the default settings.

## 12.8 Operations That Change Acoustic Output Power

Operations	Affections on Acoustic Output
Changing transducers	The maximum acoustic output power of each transducer is optimized to produce the best image quality within FDA guidelines. Thus, the acoustic output power will change as the operator changes the active transducer.
Changing imaging mode	Since B and M modes use difference default imaging parameters, changing the mode will change the acoustic output power of the system. No changes occur when switching from B to B/B, since the basic imaging parameters remain the same. In most cases, the acoustic output power for M-mode is larger than in B-mode, however, it depends in the specific presets for B and M-mode.
Field of view (sector Angle or scan Width)	Change the sector angle or scan width may result in change to the frame rate, and thus change the acoustic output power.
Changing image depth	Changing the image depth changes the PRF, and thus changes the acoustic output power.
Number of Focal Zones	Since the number of focal zones influences the frame rate and the actual position of the focal zones, changing the number of focal zones changes the acoustic output power.
Changing focus position	The transmit focus location change will cause the acoustic output power change, even though the transmitting electrical energy level and the aperture remains the same. In most cases, the acoustic output power will increase if the focal point is moved closer to the transducer.
Freezing	Active the freeze function stops the electrical energy transmit part of the system, thus disabling the system from generating ultrasound wave.
Transmit power	The transmit power level change will change the electrical output of the system to the transducer, and thus change the acoustic output power.
Changing frequency	Changing the operating frequency changes the focal characteristics of the acoustic waves, thus changes the acoustic output power.

Operations	Affections on Acoustic Output
Line density	Changing the number of acoustic lines generated (line density) affects the acoustic output power.
Preset	Since the system and user presets contain all of the above imaging parameters, changing the preset will change the acoustic output power.
Reset or Power Off/On	Resetting or powering the system on or off causes the system to return to the default status thus may change the acoustic output power.

## 12.9 References for Acoustic Power and Safety

1. "Bioeffects and Safety of Diagnostic Ultrasound" issued by AIUM in 1993
2. "Medical Ultrasound Safety" issued by AIUM in 1994
3. "Information for Manufacturers Seeking Marketing Clearance of Diagnostic Ultrasound Systems and Transducers" issued by FDA in 2008.

# Appendix A Accuracy of Measurement

Within the selected field range, the measurement accuracy is ensured within the range mentioned above. The accuracy specifications are performance in the worst conditions, or based on the real test for the system.

## ■ Depth and time

Item	Error range
Depth	Range: full screen $\leq \pm 4\%$
M-mode image time	Range: full time-axis display $\leq \pm 0.3\%$

## ■ Accuracy of Measurement

Item	Error range
Distance/Depth	Range: full screen $\leq \pm 4\%$ , or $< 2$ mm if measured value is less than 40 mm
Area (Trace)	Range: full screen $\leq \pm 8\%$ , or $< 130$ mm <sup>2</sup> if measured value is less than 1600 mm <sup>2</sup>
Area (Ellipse)	Range: full screen $\leq \pm 8\%$ , or $< 130$ mm <sup>2</sup> if measured value is less than 1600 mm <sup>2</sup>
Angle	Range: full screen $\leq \pm 3\%$
%stenosis	Range: full screen Max. 1.0 $\leq \pm 7\%$
Circumference	$\leq \pm 20\%$

## ■ Time/Motion Measurements

Item	Error range
Distance	Range: full screen $\leq \pm 4\%$ , or $< 2$ mm if measured value is less than 40 mm
Time	Range: full time-axis display $\leq \pm 1\%$
Heart Rate	Range: full time-axis display $\leq \pm 5\%$

Item	Error range
Slope	Range: full time-axis display $\leq \pm 5\%$

■ Volume Measurements

Item	Error range
Volume	Range: full screen $\leq \pm 12\%$ , or $< 8000 \text{ mm}^3$ if measured value is less than $64000 \text{ mm}^3$

# Appendix B Safety Classification

No.	Standard of Classification	Type of Product
1	According to the type of protection against electric shock	CLASS I EQUIPMENT or EQUIPMENT WITH INTERNAL POWER SUPPLY
2	According to the degree of protection against electric shock	EQUIPMENT WITH TYPE-BF APPLIED PARTS
3	Degree of protection against harmful ingress of water	Enclosure: IPX0, transducers: IPX7, foot switch: IPX8.
4	According to the degree of safety of application in the presence of a FLAMMABLE ANESTHETIC MIXTURE WITH AIR or WITH OXYGEN OR NITROUS OXIDE	EQUIPMENT not suitable for use in the presence of a FLAMMABLE ANESTHETIC MIXTURE WITH AIR or WITH OXYGEN OR NITROUS OXIDE
5	According to the mode of operation	CONTINUOUS OPERATION
6	According to the Degree of Mobility	PORTABLE EQUIPMENT MOBILE EQUIPMENT (when mounted onto the mobile trolley)



# Appendix C Guidance and Manufacturer's Declaration

The system complies with the EMC standard IEC60601-1-2: 2007.

**⚠ WARNING:** The use of unapproved accessories may diminish system performance.

- NOTE:**
1. Use of accessories, transducers, and cables other than those specified may result in increased emission or decreased immunity of system.
  2. This system should not be used adjacent to or stacked with other equipment. If adjacent or tacked use is necessary, this system should be observed to verify normal operation in the configuration in which it will be used.
  3. This system needs special precautions regarding EMC and needs to be installed and put into service according to the EMC information provided below.
  4. Preventing conducted RF immunity. Due to technological limitations, the conducted RF immunity level are limited to 1Vrms level, conducted RF interference above 1Vrms may cause wrong diagnosis and measurements. We suggested that you position this system further from sources of conducted RF noise.
  5. Operation of system, in the case that the patient physiological signal is lower than the minimum amplitude or value specified in the product specifications, may cause inaccurate results.
  6. Portable and mobile RF communications equipment can affects this system. See tables 1, 2, 3, and 4 below.

Table 1:

GUIDANCE AND MINDRAY DECLARATION—ELECTROMAGNETIC EMISSIONS		
This system is intended for use in the electromagnetic environment specified below. The customer or the user of this system should assure that it is used in such an environment.		
EMISSIONS TEST	COMPLIANCE	ELECTROMAGNETIC ENVIRONMENT—GUIDANCE
RF emissions CISPR 11	Group1	This system is suitable for use in all establishments including domestic establishments and those directly connected to the public low-voltage power supply network that supplies buildings used for domestic purposes
RF emissions CISPR 11	Class B	
Harmonic Emissions IEC61000-3-2	Class A	
Voltage Fluctuations/ Flicker Emissions IEC 61000-3-3	Compliance	



Table 2:

GUIDANCE AND MINDRAY DECLARATION—ELECTROMAGNETIC IMMUNITY			
This system is intended for use in the electromagnetic environment specified below. The customer or the user of this system should assure that it is used in such an environment.			
IMMUNITY TEST	IEC 60601 TEST LEVER	COMPLIANCE LEVER	ELECTROMAGNETIC ENVIRONMENT-GUIDANCE
Electrostatic Discharge(ESD) IEC 61000-4-2	±6 kV contact ±8 kV air	±6 kV contact ±8 kV air	Floors should be wood, concrete or ceramic tile. If floors are covered with synthetic material, the relative humidity should be at least 30%.
Electrical fast Transient/burst IEC 61000-4-4	±2 kV for power supply lines ±1 kV for input/output lines (>3m).	±2 kV for power supply lines ±1 kV for input/output lines (>3m).	Mains power quality should be that of a typical commercial or hospital environment.
Surge IEC 61000-4-5	±1 kV differential mode ±2 kV common mode	±1 kV different mode ±2 kV common mode	Mains power quality should be that of a typical commercial or hospital environment.
Voltage dips, Short interruptions and voltage variation on power supply input lines IEC 61000-4-11	<5% $U_T$ (>95% dip in $U_T$ ) for 0.5 cycle  40% $U_T$ (60% dip in $U_T$ ) for 5 cycle  70% $U_T$ (30% dip in $U_T$ ) for 25 cycle  <5% $U_T$ (>95% dip in $U_T$ ) for 5 sec	<5% $U_T$ (>95% dip in $U_T$ ) for 0.5 cycle  40% $U_T$ (60% dip in $U_T$ ) for 5 cycle  70% $U_T$ (30% dip in $U_T$ ) for 25 cycle  <5% $U_T$ (>95% dip in $U_T$ ) for 5 sec	Mains power quality should be that of a typical commercial or hospital environment. If the user of our product requires continued operation during power mains interruptions, it is recommended that our product be powered from an uninterruptible power supply or a battery.
Power frequency (50/60 HZ) magnetic field IEC 61000-4-8	3 A/m	3 A/m	Power frequency magnetic fields should be at levels characteristic of a typical location in a typical commercial or hospital environment.

$U_T$  is the A.C. mains voltage prior to application of the test level.

Table 3:

GUIDANCE AND MINDRAY DECLARATION—ELECTROMAGNETIC IMMUNITY			
This system is intended for use in the electromagnetic environment specified below. The customer or the user of this system should assure that it is used in such an environment			
IMMUNITY TEST	IEC 60601-1-2 TEST LEVEL	COMPLIANCE LEVEL	ELECTROMAGNETIC ENVIRONMENT-GUIDANCE
Conducted RF IEC 61000-4-6	3 Vrms 150kHz to 80MHz	1 Vrms	Portable and mobile RF communications equipment should be used no closer to any part of this system, including cables, than the recommended separation distance calculated from the equation applicable to the frequency of the transmitter.  Recommended separation distance $d = 3.5 \times \sqrt{P}$ $d = 1.2 \times \sqrt{P}$ 80 MHz to 800 MHz $d = 2.3 \times \sqrt{P}$ 800 MHz to 2.5GHz
Radiated RF IEC 61000-4-3	3 V/m 80MHz to 2.5 GHz	3V/m	where P is the maximum output power rating of the transmitter in watts (W) according to the transmitter manufacturer and d is the recommended separation distance in meters (m).b  Field strengths from fixed RF transmitters, as determined by an electromagnetic site survey, a should be less than the compliance level in each frequency range b  Interference may occur in the vicinity of equipment marked with the following symbol:
<p>Note:</p> <ol style="list-style-type: none"> <li>At 80 MHz and 800 MHz, the higher frequency range applies.</li> <li>These guidelines may not apply in all situations. Electromagnetic propagation is affected by absorption and reflection from structures, objects and people.</li> </ol>			
<ul style="list-style-type: none"> <li>Field strengths from fixed transmitters, such as base stations for radio (cellular/cordless) telephones and land mobile radios, amateur radio, AM and FM radio broadcast and TV broadcast cannot be predicted theoretically with accuracy. To assess the electromagnetic environment due to fixed RF transmitters, an electromagnetic site survey should be considered. If the measured field strength in the location in which this system is used exceeds the applicable RF compliance level above, this system should be observed to verify normal operation. If abnormal performance is observed, additional measures may be necessary, such as reorienting or relocating this system.</li> <li>Over the frequency ranges 150kHz to 80MHz, field strengths should be less than 1V/m.</li> </ul>			

Table 4:

RECOMMENDED SEPARATION DISTANCES BETWEEN PORTABLE AND MOBILE RF COMMUNICATION AND THIS SYSTEM			
This system is intended for use in an electromagnetic environment in which radiated RF disturbance are controlled. The customer or the user of This system can help prevent electromagnetic interference by maintaining a minimum distance between portable and mobile RF communication equipment (transmitters) and This system as recommended below, according to the maximum output power of the communication equipment.			
Rated Maximum Output power of Transmitter W (Watts)	Separation Distance According to Frequency of Transmitter M (Meters)		
	150kHz -80MHz $d = 3.5\sqrt{P}$	80MHz -800MHz $d = 1.2\sqrt{P}$	800MHz -2.5GHz $d = 2.3\sqrt{P}$
0.01	0.35	0.12	0.23
0.1	1.11	0.37	0.74
1	3.50	1.17	2.34
10	11.07	3.69	7.38
100	35.00	11.67	23.34
<p>For transmitters at a maximum output power not listed above, the recommended separation distanced in meters (m) can be determined using the equation applicable to the frequency of the transmitter, where P is the maximum output power rating of the transmitter in watts (W) according to the transmitter manufacturer.</p> <p>If image distortion occurs, it may be necessary to position this system further from sources of conducted RF noise or to install external power source filter to minimize RF noise to an acceptable level.</p> <p>Note:</p> <ol style="list-style-type: none"> <li>1. At 80 MHz and 800 MHz, the separation distance for the higher frequency range applies.</li> <li>2. These guidelines may not apply in all situations. Electromagnetic propagation is affected by absorption and reflection from structures, objects and people.</li> </ol>			



# Appendix D Electrical Safety

## Inspection

The following electrical safety tests are recommended as part of a comprehensive preventive maintenance program. They are a proven means of detecting abnormalities that, if undetected, could prove dangerous to either the patient or the operator. Additional tests may be required according to local regulations.

All tests can be performed using commercially available safety analyzer test equipment. These procedures assume the use of a 601PROXL International Safety Analyzer or equivalent safety analyzer. Other popular testers complying with IEC 60601-1 used in Europe such as Fluke, Metron, or Gerb may require modifications to the procedure. Follow the instructions of the analyzer manufacturer.

**The electrical safety inspection should be periodically performed every two years.** The safety analyzer also proves to be an excellent troubleshooting tool to detect abnormalities of line voltage and grounding, as well as total current loads.

### D.1 Power Cord Plug

#### D.1.1 The Power Plug

Test Item		Acceptance Criteria
The power plug	The power plug pins	No broken or bent pin. No discolored pins.
	The plug body	No physical damage to the plug body.
	The strain relief	No physical damage to the strain relief. No plug warmth for device in use.
	The power plug	No loose connections.
The power cord		No physical damage to the cord. No deterioration to the cord.
		For devices with detachable power cords, inspect the connection at the device.
		For devices with non-detachable power cords, inspect the strain relief at the device.

## D.2 Device Enclosure and Accessories

### D.2.1 Visual Inspection

Test Item	Acceptance Criteria
The enclosure and accessories	No physical damage to the enclosure and accessories.
	No physical damage to meters, switches, connectors, etc.
	No residue of fluid spillage (e.g., water, coffee, chemicals, etc.).
	No loose or missing parts (e.g., knobs, dials, terminals, etc.).

### D.2.2 Contextual Inspection

Test Item	Acceptance Criteria
The enclosure and accessories	No unusual noises (e.g., a rattle inside the case).
	No unusual smells (e.g., burning or smoky smells, particularly from ventilation holes).
	No taped notes that may suggest device deficiencies or operator concerns.

## D.3 Device Labeling

Check the labels provided by the manufacturer or the healthcare facility are present and legible.

- Main unit label
- Integrated warning labels

## D.4 Protective Earth Resistance

a. Plug the probes of the analyzer into the device's protective earth terminal and protective earth terminal of the AC power cord.

b. Test the earth resistance with a current of 25 A.

c. Verify the resistance is less than limits.

### ■ LIMITS

ALL COUNTRIES R = 0.2  $\Omega$  Maximum

## D.5 Earth Leakage Test

Run an Earth Leakage test on the device being tested before performing any other leakage tests.

The following outlet conditions apply when performing the Earth Leakage test.

- normal polarity( Normal Condition);
- reverse polarity( Normal Condition);
- normal polarity with open neutral(Single Fault Condition);
- reverse polarity with open neutral(Single Fault Condition).

■ LIMITS

For UL60601-1,

- 300  $\mu$ A in Normal Condition.
- 1000  $\mu$ A in Single Fault Condition.

For IEC60601-1,

- 500  $\mu$ A in Normal Condition.
- 1000  $\mu$ A in Single Fault Condition.

## D.6 Enclosure Leakage Test

The following outlet conditions apply when performing the Enclosure Leakage test.

- normal polarity( Normal Condition);
- reverse polarity( Normal Condition);
- normal polarity with open neutral(Single Fault Condition);
- reverse polarity with open neutral(Single Fault Condition);
- normal polarity with open earth(Single Fault Condition);
- reverse polarity with open earth(Single Fault Condition).

■ LIMITS

For UL60601-1,

- 100 $\mu$ A in Normal Condition.
- 300  $\mu$ A in Single Fault Condition.

For IEC60601-1:

- 100 $\mu$ A in Normal Condition.
- 500  $\mu$ A in Single Fault Condition.

## D.7 Patient Leakage Current

Patient leakage currents are measured between a selected applied part and mains earth. All measurements have a true RMS only.

The following outlet conditions apply when performing the Patient Leakage Current test.

- normal polarity( Normal Condition);
- reverse polarity( Normal Condition),
- normal polarity with open neutral(Single Fault Condition);
- reverse polarity with open neutral(Single Fault Condition).
- normal polarity with open earth(Single Fault Condition);
- reverse polarity with open earth(Single Fault Condition).

■ LIMITS

For BF  applied parts,

- 100 $\mu$ A in Normal Condition.
- 500 $\mu$ A in Single Fault Condition.

## D.8 Mains on Applied Part Leakage

The Mains on Applied Part test applies a test voltage, which is 110% of the mains voltage, through a limiting resistance, to selected applied part terminals. Current measurements are then taken between the selected applied part and earth. Measurements are taken with the test voltage (110% of mains) to applied parts in the normal and reverse polarity conditions.

The following outlet conditions apply when performing the Mains on Applied Part test.

- Normal Polarity;
- Reversed Polarity.

### ■ LIMITS

- For BF  applied parts: 5000  $\mu$ A.

## D.9 Patient Auxiliary Current

Patient Auxiliary currents are measured between any selected Applied Part connector and the remaining Applied Part connectors. All measurements may have a true RMS only response.

The following outlet conditions apply when performing the Patient Auxiliary Current test.

- normal polarity( Normal Condition);
- reverse polarity( Normal Condition);
- normal polarity with open neutral(Single Fault Condition);
- reverse polarity with open neutral(Single Fault Condition);
- normal polarity with open earth(Single Fault Condition);
- reverse polarity with open earth(Single Fault Condition).

### ■ LIMITS

For BF  applied parts,

- 100 $\mu$ A in Normal Condition.
- 500 $\mu$ A in Single Fault Condition.

**Note:** Make sure the safety analyzer is authorized comply with requirement of IEC61010-1.  
Follow the instructions of the analyzer manufacturer.



