



# GIMA

PROFESSIONAL MEDICAL PRODUCTS

**DEAMBULATORE ASCELLARE**  
**AXILLARY WALKING FRAME**  
**DÉAMBULATEUR AXILLAIRE**  
**GEHILFE MIT ACHSELSTÜTZE**  
**ANDADOR AXILAR**  
**ANDARILHO AUXILIAR**  
**ΠΕΡΙΠΑΤΗΤΗΡΑΣ ΜΕ ΥΠΟΜΑΣΧΑΛΙΑ**  
**AXILÄR GÅNGRAM**

È necessario segnalare qualsiasi incidente grave verificatosi in relazione al dispositivo medico da noi fornito al fabbricante e all'autorità competente dello Stato membro in cui si ha sede.

All serious accidents concerning the medical device supplied by us must be reported to the manufacturer and competent authority of the member state where your registered office is located.

Il est nécessaire de signaler tout accident grave survenu et lié au dispositif médical que nous avons livré au fabricant et à l'autorité compétente de l'état membre où on a le siège social.

Jeder schwere Unfall im Zusammenhang mit dem von uns gelieferten medizinischen Gerät muss unbedingt dem Hersteller und der zuständigen Behörde des Mitgliedsstaats, in dem das Gerät verwendet wird, gemeldet werden.

Es necesario informar al fabricante y a la autoridad competente del Estado miembro en el que se encuentra la sede sobre cualquier incidente grave que haya ocurrido en relación con el producto sanitario que le hemos suministrado.

É necessário notificar ao fabricante e às autoridades competentes do Estado-membro onde ele está sediado qualquer acidente grave verificado em relação ao dispositivo médico fornecido por nós.

Σε περίπτωση που διαπιστώσετε οποιοδήποτε σοβαρό περιστατικό σε σχέση με την ιατρική συσκευή που σας παρέχουμε θα πρέπει να το αναφέρετε στον κατασκευαστή και στην αρμόδια αρχή του κράτους μέλους στο οποίο βρίσκεστε.

Det är nödvändigt att meddela tillverkaren och de behöriga myndigheterna i den berörda medlemsstaten, om alla allvariga olyckor som inträffat i samband med den medicintekniska utrustning som levererats av oss.

**REF YDL03 (GIMA 43134)**



INTCO MEDICAL (HK) CO., LTD  
FLAT/RM 19C, LOCKHART CENTRE, 301-307  
LOCKHART ROAD, WAN CHAI, HONG KONG, P.R. China  
Made in China

Importato da/Imported by/Importé par/ Eingeführt von  
Importado por/Eισαγωγή από/Importerad av:

**Gima S.p.A.**  
Via Marconi, 1 - 20060 Gessate (MI) Italy  
gima@gimaitaly.com - export@gimaitaly.com  
[www.gimaitaly.com](http://www.gimaitaly.com)



EC REF MedNet EC-REP GmbH  
Borkstrasse 10, 48163 Muenster, Germany



## INSTRUCTIONS D'UTILISATION

Posez le cadre plié sur le sol, vérifiez les quatre roulettes et verrouillez.

Poussez la barre d'accouplement verticale (24) dans le tube droit (23) de la partie accoudoir, puis utilisez le bouton (8) pour la verrouiller.

Poussez les deux accoudoirs de recharge avec la poignée dans le tube fixe (7) et verrouillez-les à la hauteur désirée à l'aide du bouton de réglage.







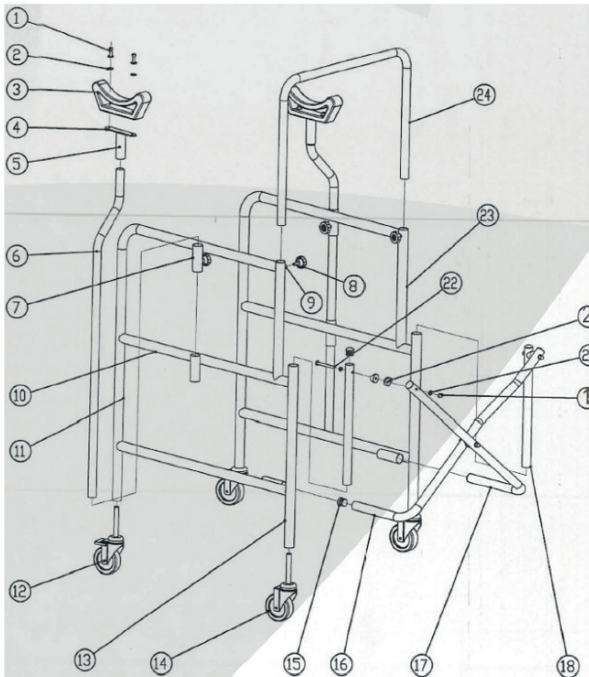



Le siège peut être facilement inséré et retiré du cadre par les 4 crochets dont il est équipé.

Pour marcher avec le déambulateur, soulevez-le et placez-le devant vous et, en vous assurant que les quatre pieds reposent fermement sur le sol, faites un pas à la fois.

Poids max : 120 kg



1. Rivet
2. Washer
3. Axillary support part
4. Fixed part
5. Fixed tube for cross bar
6. Axillary support tube
7. Fixed tube for axillary support
8. Adjusting knob
9. Fixednut
10. Fixed rail
11. Straight tube of armrest part
12. Locking castors
13. Rear straight tube
14. Non locking castors
15. Pipe close
16. Cross bar
17. Cross bar
18. Guide bar
19. Plastic acorn nut
20. Flat washer
21. Cross bar washer
22. Cross bar screw
23. Straight tube of armrest part
24. Vertical connecting rod

	Manufacturer		Keep in a cool, dry place
	Consult instructions for use		Keep away from sunlight
	Product code		Lot number
	Date of manufacture		Medical Device
	Authorized representative in the European community		Caution: read instructions (warnings) carefully
	Medical Device compliant with Regulation (EU) 2017/745		

### GIMA WARRANTY TERMS

The Gima 12-month standard B2B warranty applies.