

IFU PRINTING SPECIFICATION SHEET

PAGE LAYOUT

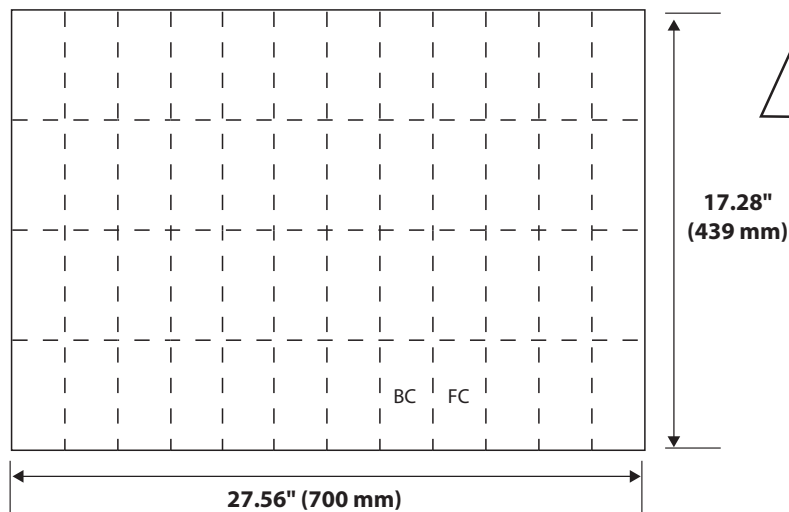

Flat Size

FOLD PATTERN

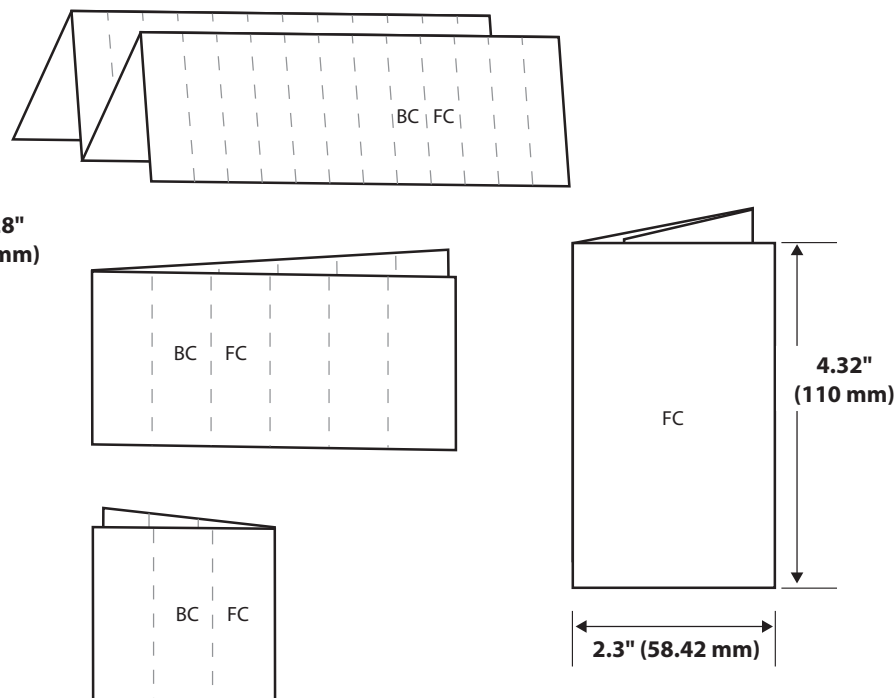

Folded Size

TITLE ETHILON™		DESCRIPTION Map IFU		LAB NUMBER LAB100601593v2	SPECIAL INSTRUCTIONS/COMMENTS n/a		BINDING n/a	COLORS Black			
FLAT SIZE 27.56" x 17.28" 700 mm x 439 mm		FOLDED SIZE 2.3" x 4.32" 58.42 mm x 110 mm		RMC NUMBER 390323R02	PAGE COUNT 2	LANGUAGES ar, cs, da, de, el, en, es, fi, fr, hu, it, kk, ko, nl, no, pl, pt, ro, ru, sk, sv, tr, zh-cn, zh-tw		SELF COVER <input checked="" type="checkbox"/>	PLUS COVER <input type="checkbox"/>	SEALING METHOD <input type="checkbox"/>	WAFER SEAL <input checked="" type="checkbox"/>
BLEED SIZE .5" (12.7 mm) <input type="checkbox"/> .125" (3.175 mm) <input type="checkbox"/>		NONE <input checked="" type="checkbox"/>	BLEED ALL SIDES <input type="checkbox"/>	BLEED TOP <input type="checkbox"/>	BLEED RIGHT <input type="checkbox"/>	BLEED LEFT <input type="checkbox"/>	BLEED BOTTOM <input type="checkbox"/>				
STOCK Refer to MS159-007					<p>DRAWING IS NOT TO SCALE: DRAWINGS REFLECT INFORMATION FOR PRODUCTION OF PRINTED PIECES AND DO NOT CONTAIN ACTUAL ARTWORK. This document or data herein or herewith is not to be reproduced, used or disclosed in whole or part without the permission of Ethicon, Inc.</p> <p style="text-align: center;">ETHICON</p>						