

IFU PRINTING SPECIFICATION SHEET

PAGE LAYOUT

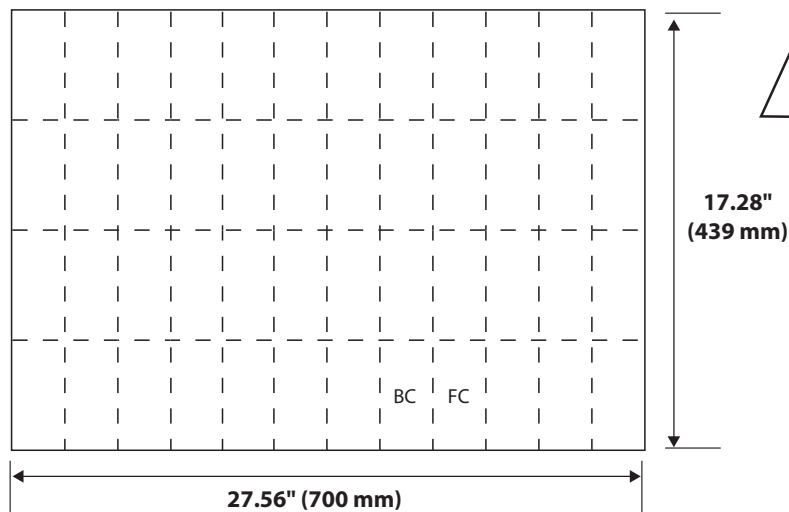

27.56" (700 mm)

17.28"
(439 mm)

Flat Size

FOLD PATTERN

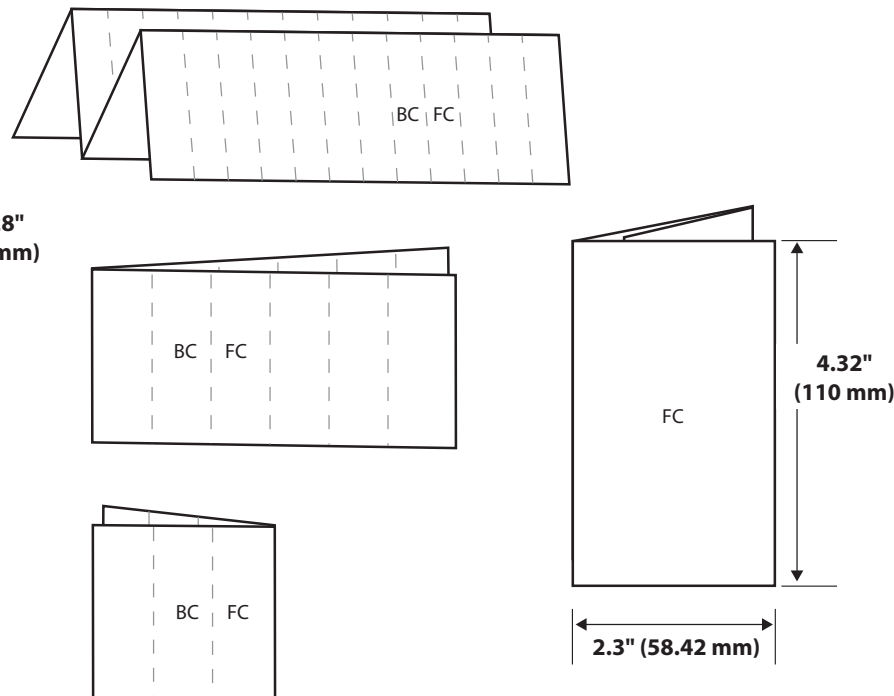

2.3" (58.42 mm)

4.32"
(110 mm)

Folded Size

| | | | | | | | | | | | | |
|--|--|---|--|-------------------------------------|---|-------------------------------------|--|----------------|---|--|----------------|---|
| TITLE ETHILON™ | | DESCRIPTION Map IFU | | LAB NUMBER LAB100601593v2 | SPECIAL INSTRUCTIONS/COMMENTS n/a | | | BINDING n/a | COLORS Black | | | |
| FLAT SIZE 27.56" x 17.28" 700 mm x 439 mm | | FOLDED SIZE 2.3" x 4.32" 58.42 mm x 110 mm | | RMC NUMBER 390323R02 | PAGE COUNT 2 | | LANGUAGES ar, cs, da, de, el, en, es, fi, fr, hu, it, kk, ko, nl, no, pl, pt, ro, ru, sk, sv, tr, zh-cn, zh-tw | | SELF COVER <input checked="" type="checkbox"/> | PLUS COVER <input type="checkbox"/> | SEALING METHOD | WAFER SEAL <input checked="" type="checkbox"/> |
| BLEED SIZE .5" (12.7 mm) <input type="checkbox"/> .125" (3.175 mm) <input type="checkbox"/> | | NONE <input checked="" type="checkbox"/> BLEED ALL SIDES <input type="checkbox"/> | | BLEED TOP <input type="checkbox"/> | BLEED RIGHT <input type="checkbox"/> | BLEED LEFT <input type="checkbox"/> | BLEED BOTTOM <input type="checkbox"/> | | | | | |
| STOCK Refer to MS159-007 | | | | | <p>DRAWING IS NOT TO SCALE: DRAWINGS REFLECT INFORMATION FOR PRODUCTION OF PRINTED PIECES AND DO NOT CONTAIN ACTUAL ARTWORK. This document or data herein or herewith is not to be reproduced, used or disclosed in whole or part without the permission of Ethicon, Inc.</p> <p style="text-align: center;">ETHICON</p> | | | | | | | |