



GIMA

PROFESSIONAL MEDICAL PRODUCTS

PULSOXIMETRO OXY-50
OXY-50 PULSE OXIMETER
OXYMÈTRE DE POULS OXY-50
PULSIOXÍMETRO OXY-50
PULSOXÍMETRO OXY-50
OXI-50 PULSOXIMETER
PULSOKSYMETR OXY-50
PULSOXIMETRU OXY-50
OXY-50 PULSE OXIMETER
OXY-50 ΠΑΛΜΙΚΟ ΟΞΥΜΕΤΡΟ
OXY-50 PULSOXIMETER
OXY-50 PULZOXIMÉTER

REF 35100



Gima S.p.A.
Via Marconi, 1 - 20060 Gessate (MI) Italy
gima@gimaitaly.com - export@gimaitaly.com
www.gimaitaly.com
Made in China

CH **REP**

Medicare AG, Hauptstr. 51
5024 Küttigen, Schweiz
CHRN-AR-20002506

UK **REP**

Maclin Power Ltd, 20 Wenlock Road,
London, N1 7GU England,
United Kingdom

IP22



0476



Instructions to User

Dear users, thank you very much for purchasing the Pulse Oximeter (hereinafter referred to as device).

This Manual is written and compiled in accordance with the council directive MDD93/42/EEC for medical devices and harmonized standards. In case of modifications and software upgrades, the information contained in this document is subject to change without notice.

It is a medical device, which can be used repeatedly.

The Manual describes, in accordance with the device's features and requirements, main structure, functions, specifications, correct methods for transportation, installation, usage, operation, repair, maintenance and storage, etc. as well as the safety procedures to protect both the user and device. Refer to the respective chapters for details.

Please read the User Manual carefully before using this device. The User Manual which describes the operating procedures should be followed strictly. Failure to follow the User Manual may cause measuring abnormality, device damage and human injury. The manufacturer is NOT responsible for the safety, reliability and performance issues and any monitoring abnormality, human injury and device damage due to users' negligence of the operation instructions. The manufacturer's warranty service does not cover such faults.

Owing to the forthcoming renovation, the specific products you received may not be totally in accordance with the description of this User Manual. We would sincerely regret for that.

Our company has the final interpretation to this manual. The content of this manual is subject to change without prior notice.

Warnings

Remind that it may cause serious consequences to tester, user or environment.

- Explosive hazard—DO NOT use the device in environment with inflammable gas such as anesthetic.
- DO NOT use the device while examining by MRI or CT, as the induced current may cause burn.
- Do not take the information displayed on the device as the sole basis for clinical diagnosis. The device is only used as an auxiliary means in diagnosis. And it must be used in conjunction with doctor's advice, clinical manifestations and symptoms.
- The maintenance to the device can only be performed by qualified service personnel specified by manufacturer. Users are not permitted to maintain or refit the device by themselves.
- Uncomfortable or painful feeling may appear if using the device ceaselessly, especially for the microcirculation disturbance users. It is not recommended that the sensor is used on the same finger for more than 2 hours.
- For some special users who need a more careful inspection on the test site, please don't place the device on the edema or tender tissue.
- Please do not stare at the red and infrared light emitter (the infrared light is invisible) after turning on the device, including the maintenance staff, as it may be harmful to the eyes.
- The device contains silicone, PVC, TPU, TPE and ABS materials, whose biocompatibility has been tested in accordance with the requirements in ISO 10993-1, and it has passed the recommended biocompatibility test. The person who is allergic to silicone, PVC, TPU, TPE or ABS can not use this device.
- The disposal of scrap device, its accessories and packaging should follow the local laws and regulations, to avoid polluting to the local environment. And the packaging materials must be placed in the region where the children are out of reaching.
- The device can not be used with the equipment not specified in the Manual. Only the accessories appointed or recommended by the manufacturer can be used, otherwise it may cause injury to the tester and operator or damage to the device.
- The SpO₂ probe accompanied is only suitable for using with the device. The device can only use the SpO₂ probe described in the Manual, so the operator has the responsibility to check the compatibility between the device and the SpO₂ probe before using, incompatible accessories may cause device performance degradation, device damage or patient injury.
- Do not reprocess the accompanying SpO₂ probe.
- Check the device before use to make sure that there is no visible damage that may affect user's safety and device performance. When there is obvious damage, please replace the damaged parts before use.
- When the message "Sensor Off" or "Sensor Fault" appears on the screen, it indicates that the SpO₂ probe is disconnected or line fault occurs. Check the connection of the SpO₂ probe and whether there is damage for the probe, if necessary, please replace the probe to avoid risks. The probe fault will not result in a safety hazard.
- Functional testers can not be used to assess the accuracy of the SpO₂ probe and Pulse Oximeter.
- Some functional testers or patient simulators can be used to verify whether the device works normally, for example, INDEX-2LFE Simulator (software version: 3.00), please refer to the Manual for the detailed operation steps.
- Some functional testers or patient simulators can measure the accuracy of the device copied calibration cur-

ve, but they can not be used to evaluate the device accuracy.

- When using the device, please keep it away from the equipment which can generate strong electric field or strong magnetic field. Using the device in an inappropriate environment may cause interference to the surrounding radio equipment or affect its working.
- The measured accuracy will be affected by the interference of electrosurgical equipment.
- When several products are used on the same patient(people) simultaneously, danger may occur which is arisen from the overlap of leakage current.
- CO poisoning will appear excessive estimation, so it is not recommended to use the device.
- This device is not intended for treatment.
- The intended operator of the device may be a patient.
- Avoid maintaining the device during using.

1 OVERVIEW

The oxygen saturation is the percentage of HbO₂ in the total Hb in the blood, so-called the O₂ concentration in the blood, it is an important physiological parameter for the respiratory and circulatory system. A number of diseases related to respiratory system may cause the decrease of SpO₂ in the blood, furthermore, some other causes such as the malfunction of human body's self-adjustment, damages during surgery, and the injuries caused by some medical checkup would also lead to the difficulty of oxygen supply in human body, and the corresponding symptoms would appear as a consequence, such as vertigo, impotence, vomit etc. Serious symptoms might bring danger to human's life. Therefore, prompt information of patients' SpO₂ is of great help for the doctor to discover the potential danger, and is of great importance in the clinical medical field.

Insert the finger when measuring, the device will directly display the SpO₂ value measured, it has a higher accuracy and repeatability.

1.1 Features

- A. Easy to use.
- B. Small in volume, light in weight, convenient to carry.
- C. Low power consumption.

1.2 Applied range

The Pulse Oximeter can be used in measuring the pulse oxygen saturation and pulse rate through finger. The product is suitable for being used in family, hospital, oxygen bar, community healthcare, physical care in sports (It can be used before or after doing sports, and it is not recommended to use the device during the process of having sport) and etc.

1.3 Environment requirements

Ambiente di conservazione

Storage Environment

- a) Temperature: -40°C ~ + 60°C
- b) Relative humidity: ≤ 95%
- c) Atmospheric pressure: 500 hPa ~ 1060 hPa

Operating Environment

- a) Temperature: +10°C ~ + 40°C
- b) Relative Humidity: ≤ 75%
- c) Atmospheric pressure: 700 hPa ~ 1060 hPa

1.4 Precautions

1.4.1 Attention

Point out conditions or practices that may cause damage to the device or other properties

- ⚠ Before using the device, make sure that it locates in normal working state and operating environment.
- ⚠ In order to get a more accurate measurement, it should be used in a quiet and comfortable environment.
- ⚠ When it is carried from cold environment to warm or humid environment, please do not use it immediately.
- ⚠ If the device is splashed or coagulated by water, please stop operating.
- ⚠ DO NOT operate the device with sharp things.
- ⚠ High temperature, high pressure, gas sterilizing or immersion disinfection for the device is not permitted. Refer to User Manual in the relative chapter (6.1) for cleaning and disinfection. Please turn off the device before cleaning and disinfection. Please take out the internal battery before cleaning and disinfection.

- 🔔 The device is suitable for children and adult.
- 🔔 The device may not be suitable for all users, if you can't get a satisfactory result, please stop using it.
- 🔔 Data averaging and signal processing have a delay in the upgrade of SpO₂ data values. When the data update period is less than 30 seconds, the time for obtaining dynamic average values will increase, which is arisen from signal degradation, low perfusion or other interference, it depends on the PR value.
- 🔔 The device has 3-year service life, date of manufacture: see the label.
- 🔔 This device has the function of prompting, users can check on this function according to chapter 5.5.1 as a reference.
- 🔔 The device has the function of limits prompting, when the measured data is beyond the highest or lowest limit, the device would start prompting automatically on the premise of the prompting function is on.
- 🔔 The device has the function of prompting, this function can either be paused, or closed (default setting) for good. This function could be turned on through menu operation if you need. Please check the chapter 5.5.1 as a reference.
- 🔔 The device hasn't low-voltage prompt function, it only shows the low-voltage, please change the battery when the battery voltage is used up.
- 🔔 The maximum temperature at the SpO₂ probe -tissue interface should be less than 41°C which is measured by the temperature tester.
- 🔔 During measuring, when abnormal conditions appear on the screen, please pull out your finger and reinsert it to measure again.
- 🔔 If some unknown error appears during measuring, remove the battery to terminate operating.
- 🔔 Do not contort or drag the wire of the device.
- 🔔 The plethysmographic waveform is not normalized, as a signal inadequacy indicator, when it is not smooth and stable, the accuracy of the measured value may degrade. When it tends to be smooth and stable, the measured value read is the optimal and the waveform at this time is also the most standard.
- 🔔 If necessary, please visit our official website to get the information about SpO₂ probe that can be used with this device.
- 🔔 If the device or component is intended for single-use, then the repeated use of these parts will pose risks on the parameters and technical parameters of the equipment known to the manufacturer.
- 🔔 If necessary, our company can provide some information (such as circuit diagrams, component lists, illustrations, etc.), so that the qualified technical personnel of the user can repair the device components designated by our company.
- 🔔 The measured results will be influenced by the external colouring agent (such as nail polish, colouring agent or color skin care products, etc.), so don't use them on the test site.
- 🔔 As to the fingers which are too cold or too thin or whose fingernail is too long, it may affect the measured results, so please insert the thicker finger such as thumb or middle finger deeply enough into the probe when measuring.
- 🔔 The finger should be placed correctly (see Attached figure 6), as improper installation or improper contact position for sensor will influence the measurement.
- 🔔 The light between the photoelectric receiving tube and the light-emitting tube of the device must pass through the subject's arteriole. Make sure the optical path is free from any optical obstacles like rubberized fabric, to avoid inaccurate results.
- 🔔 Excessive ambient light may affect the measured results, such as surgical light (especially xenon light sources), bilirubin lamp, fluorescent lamp, infrared heater and direct sunlight, etc. In order to prevent interference from ambient light, make sure to place the sensor properly and cover the sensor with opaque material.
- 🔔 Frequent movement (active or passive) of the subject or severe activity can affect the measured accuracy.
- 🔔 The SpO₂ probe should not be placed on a limb with the blood pressure cuff, arterial ductus or intraluminal tube.
- 🔔 The measured value may be inaccurate during defibrillation and in a short period after defibrillation, as it has not defibrillation function.
- 🔔 The device has been calibrated before leaving factory.
- 🔔 The device is calibrated to display functional oxygen saturation.
- 🔔 The equipment connected with the Oximeter interface should comply with the requirements of IEC 60601-1.

1.4.2 Clinical restriction

- A. As the measure is taken on the basis of arteriole pulse, substantial pulsating blood flow of subject is required. For a subject with weak pulse due to shock, low ambient/body temperature, major bleeding, or use of vascular contracting drug, the SpO₂ waveform (PLETH) will decrease. In this case, the measurement will be more sensitive to interference.
- B. The measurement will be influenced by intravascular staining agents (such as indocyanine green or methylene blue), skin pigmentation.
- C. The measured value may be normal seemingly for the tester who has anemia or dysfunctional hemoglobin (such as carboxyhaemoglobin (COHb), methaemoglobin (MetHb) and sulphaemoglobin (SuHb)), but the tester may appear hypoxia, it is recommended to perform further assessment according the clinical situations and symptoms.

D. Pulse oxygen only has a reference meaning for anemia and toxic hypoxia, as some severe anemia patients still show better pulse oxygen measured valued.

E. Contraindication: no

2 PRINCIPLE

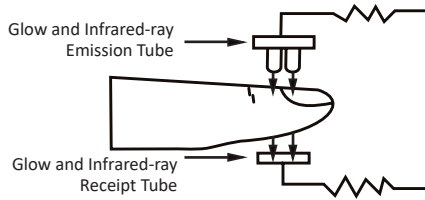

Figure 1 Operating principle

Principle of the Oximeter is as follows: An experience formula of data process is established taking use of Lambert Beer Law according to Spectrum Absorption Characteristics of Reductive Hemoglobin (Hb) and Oxyhemoglobin (HbO₂) in glow & near-infrared zones. Operation principle of the device is: Photoelectric Oxyhemoglobin Inspection Technology is adopted in accordance with Capacity Pulse Scanning & Recording Technology, so that two beams of different wavelength of lights can be focused onto human nail tip through perspective clamp finger-type sensor. Then measured signal can be obtained by a photosensitive element, information acquired through which will be shown on screen through treatment in electronic circuits and microprocessor.

3 FUNCTIONS

3.1. Main performance

- A. SpO₂ value display
- B. Pulse rate value display, bar graph display
- C. Pulse waveform display
- D. Low-voltage indication: low-voltage indicator appears before working abnormally which is due to low-voltage
- E. Screen brightness can be changed
- F. Pulse sound indication
- G. Voice prompt for over-limit, probe off /finger-out and low battery
- H. With SpO₂ value and pulse rate value record function, the stored data can be uploaded to computer
- I. It can be connected with an external oximeter probe
- J. Real-time data can be transmitted to computer
- K. Review function
- L. Clock function

4 INSTALLATION

4.1 View of the front panel

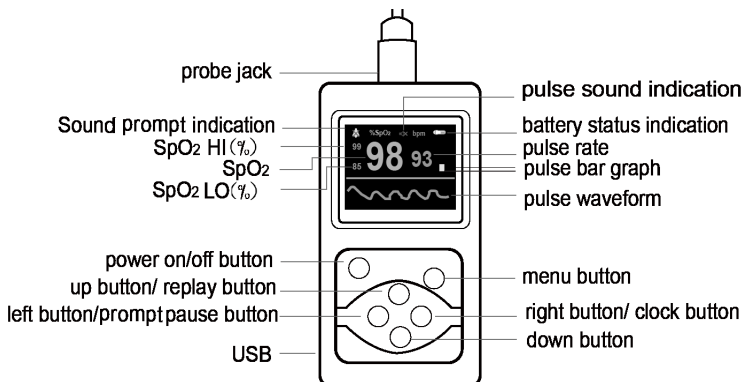

Figure 2. Front View

4.2 Battery installation

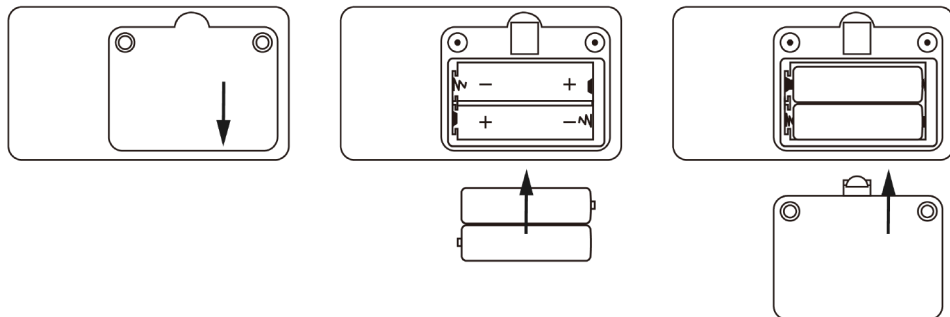

Figure 3. Batteries Installation

- A. Refer to Figure 3. Use a screwdriver to unscrew the two screws from the battery compartment on the back of the product and open the back cover of the battery compartment.
- B. Insert the two AA size batteries properly in the right direction.
- C. Replace the cover, screw on the screw.



Please take care when you insert the batteries, for the improper insertion may damage the device.



Please replace two new batteries of the same kind at the same time.

4.3 Probe installation

Inserting the SpO2 probe of the pulse oximeter in the upper jack(see Figure 4). (The probe is limited to be produced by our company; never replace it with the similar one by other manufacturers).

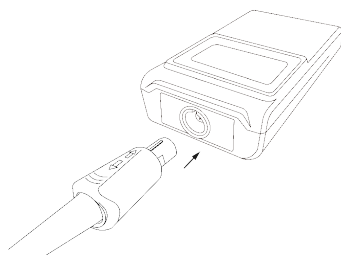

Figure 4. Probe Installation



Figure 5. USB Port



When inserting the probe, make the protruding part of the probe plug correspond to the groove of the probe socket. Pull out the probe directly and don't rotate the probe.

4.4 USB port

It is used to connect a personal computer to export the trend data or charge the lithium battery via a data line(see Figure 5).

4.5. Structure and accessories

- A. Structure: main unit, probe, USB cable, Bluetooth adapter (optional).
- B. Accessories: one adult-oximeter probe, two AA size batteries (optional), one USB cable, one CD disk (including PC software, optional), one User Manual, Bluetooth adapter (optional).

Please check the device and accessories according to the list to avoid that the device can not work normally.

C. Software description

Software name: CMS60D embedded software

Software specification: no

Release version: V2.0

Naming rule for version: V <Major enhance software upgrade>.<Minor enhance software upgrade>.<Improvement software upgrade>

Involved algorithm: name: plethysmography; type: mature arithmetic

Purpose: be used to measure SpO₂, pulse rate, etc.

Clinical function: calculate SpO₂ and pulse rate values by collecting and processing the testee's pulse signal.

5 OPERATING GUIDE

5.1 Application method

A. Put the finger into the probe. Refer to Figure 6.

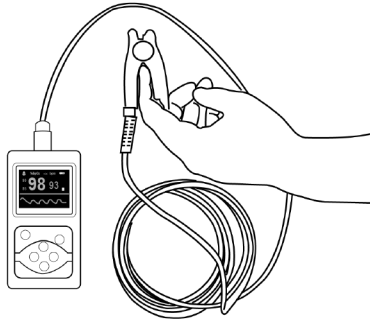

Figure 6 (Actual probe may be different with the probe as Figure 6, please accept the actual probe with the device)



Fingernails and the luminescent tube should be at the same side.



In the process of using the tested finger had better not shake, the human body also had better not be in motion state.

B. Long press the "power on/off " button, until the device turns on.

C. Do not shake the finger and keep the user in a stable state during the process.

D. The data can be read directly from the screen in the measure interface.

5.2 Pause sound prompt

A. Sound prompt, including: over-limit, low-battery and probe or finger out.

B. Under the measurement interface, turn on the sound prompt, when the sound prompt occurs, short press the button to pause the sound prompt, and it will resume automatically after about 60s.

C. If you want to turn off the sound prompt permanently, please set it in menu.

5.3 Review Interface

A. In the measure interface,press "up button" to enter the Review Interface 1 directly, as shown in Figure 7:

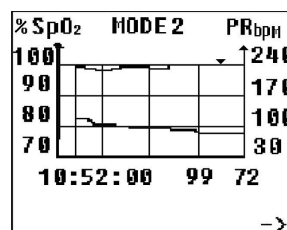
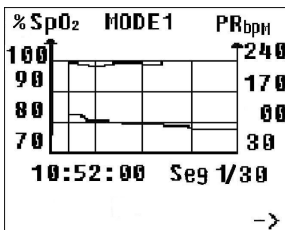

Figure 7-1. Review Interface 1

Figure 7-2. Review Interface 2

- B. In review interface, press “menu button” to switch between Review Interface 1 and Review Interface 2.
- C. In Review Interface 1, the user can observe the trend waveform composed by storage data. Each screen can show storage data for 105 seconds. The yellow line shows the SpO2 trend waveform, and the red line shows the PR trend waveform. The time underside shows the starting time of displaying the date in the screen, the middle “+” and “-” at the underside of the screen means the operation direction of the “Down button”. Press “right button”, it will show “+” in the position, then press “Down button” to enter next hour; Press “left button”, it will show “-” in the position, then press “Down button” to enter last hour.
- D. The Review Interface 2 shown based in Review Interface 1, the stored SpO2 value and PR value in each second can be observed here, the underside date from left to right marks time, SpO2 value, PR value. When the stored data exceeds the upper and lower limit set by user, the relevant value will turn green.
- E. Press “up button” to exit the review Interface, return to the measure interface.

5.4 Clock interface

In the measure interface, press the “right button” can enter the clock interface of Figure 8. Press the “right button” again can return to the measure interface.

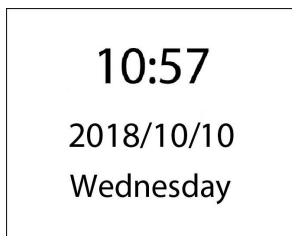

Figure 8. Clock interface

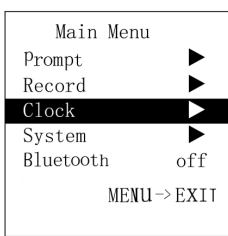

Figure 9. Main Menu

Prompt Menu	
SpO2 HI (%)	099
SpO2 LO (%)	085
PR HI (bpm)	120
PR LO (bpm)	030
Prompt Sound	ON
Pulse Sound	ON
MENU->EXIT	

Figure 10 Setting for sound prompt

5.5 Menu operations:

In the measure interface, press the “menu button” can enter the menu of Figure 9. Users can adjust the setting through the main menu, such as the sound prompt, record, clock., system, etc. can be set, methods are as followings:

5.5.1 Sound prompt setting

Under main menu, press the “up button” or “down button” to select “Prompt”, then press the “up button” or “down button” to enter its setting interface shown in Figure 10.

Press the “up button” or “down button” to select the option to be adjusted, then press the “left button” or “right button” to change the value.

- “SpO2 HI(%)”: upper limit prompt for SpO2 over-limit
- “SpO2 LO(%)”: lower limit prompt for SpO2 over-limit
- “PR HI(bpm)”: upper limit prompt for PR over-limit
- “PR LO(bpm)”: lower limit prompt for PR over-limit
- “Prompt Sound”: prompt for over-limit, “off”: close, “on”: open.
- “Pulse Sound”: PR sound, “off”: close, “on”: open.

Lower limit can not exceed the upper limit, and the upper limit can not be lower than the lower limit when adjusting the values. SpO2 range: 0 % ~ 100 %, PR range: 0 ~ 254 bpm

The values displayed in Figure 10 are the initial values of over-limit prompt.

After setting, press the “menu button” to exit the Prompt Settings Menu interface, and return to “Main Menu” interface.

5.5.2 Data storage

Under the main menu, press the “up button” or “down button” to select “Record”, then press the “up button” or “down button” to enter the “Record Menu” interface as shown in Figure 11.

Press the “up button” or “down button” to select the option to be adjusted, then press the “left button” or “right button” to change the value.

It indicates that the device is storing when the red dot “R●” in measurement interface flickers “Mode”: record mode selection, including: “Auto” and “Manual” mode. Under “Manual” mode, select to turn on / off memory by “Record”. Auto record: start recording after stable data appear, pull out the finger to finish recording a group of data (99 group of data at most), the total duration does not exceed 72 hours.

Manual record: after manual storage is started, the storage state needs to be terminated manually to complete a group of store, store up to 24-hour data.

When the memory is full, it will display “Memory is full!”, then it will enter the standby mode after several seconds. When exiting the standby mode next time, it will display “Memory is full!” to prompt user that the memory has been full, press any button (power on/off excluded) again, it will enter the measure interface.



Under manual mode, when “Record” is “ON”, the device will prompt to clear the data stored last time.

It will display “Recording...” when there is no operation under record state for 30s, then it will enter energy saving mode after several seconds, pressing the “power on/off button”, the device would return to the former interface; pressing any button(power on/off excluded), it will display “Recording”.



Under data recording state, after the display screen turns off automatically, in order to save power, pulse sound indication will turn off automatically.

“Seg”: data segment.

After setting, press the “menu button” to exit storage menu, return to main menu.

“Delete All”: delete all records (auto record mode is shown as Figure 11).



Please upload data in time after recording, otherwise the data may be covered when the storage space is full.



The historical data will be deleted once switching the mode. Under record state, the record mode can not be switched; under manual mode, the record mode can be switched only when turning off recording firstly.

Record Menu	
Mode	Auto
Seg	12
Delete All	
MENU->EXIT	

Figure 11 Main menu

Clock Menu	
Set Time	no
Set Year	2019
Set Month	01
Set Day	01
Set Hour	03
Set Minute	00
MENU->EXIT	

Figure 12 Clock menu

System Menu	
Hard. Ver.	2.0.0
Soft. Ver.	2.0.2
ID	user
Demo	off
Sound Volume	3
Brightness	1
MENU->EXIT	

Figure 13 System menu

5.5.3 Clock setting

a. Connect the master device to synchronize device time

Under the PC software interface, after search for the device (refer to relative chapter (5.6) for the connection method), then can synchronize the device time.

b. Set device time manually

Under main menu, press the “up button” or “down button” to select “Clock”, then press the “left button” or “right button” to enter its setting interface shown in Figure 12.

Press the “up button” or “down button” to select the option to be adjusted, then press the “left button” or “right button” to change the value.

“Set Time”: set the time, “yes”: allow, “no”: prohibit

“Set Year”: set the year

“Set Month”: set the month

“Set Day”: set the day

“Set Hour”: set the hour

“Set Minute”: set the minute

Adjustable range for year: 2015 ~ 2045, month: 1 ~ 12, day: 1 ~ 30 (when there are 31 days in a month, it is 1 ~ 31), hour: 1 ~ 23, minute: 1 ~ 59.

After setting, press the “menu button” to exit clock menu, return to main menu.

5.5.4 System setting and other options introduction

Under main menu, press the “up button” or “down button” to select “System”, then press the “left button” or “right button” to enter the interface as shown in Figure 13.

Press the “up button” or “down button” to select the option to be adjusted, then press the “left button” or “right button” to change the value.

“Hard.Ver.”: hardware version

“Soft.Ver.”: software version

“ID”: user name

“Demo”: set the Demo mode, “on”: turn on the Demo mode, “off”: turn off the Demo mode.

“Sound Volume”: set the sound volume, adjustable range: 1 ~ 3

“Brightness”: set the screen brightness, adjustable range: 1 ~ 4

After setting, press the “menu button” to exit system setting menu, return to main menu.

5.5.5 Bluetooth setting (Bluetooth equipment)

Under main menu, press the “up button” or “down button” to select “Bluetooth”, then press the “left button” or “right button” to enter its selection interface as shown in Figure 14 and Figure 15 When the Bluetooth is “ON”, if no data is transmitted for some time, then the Bluetooth will be turned off automatically.



Under transmitting data by Bluetooth, the Bluetooth can not be turned off.

Turn On BT?
Yes **No**

Figure 14 Bluetooth “ON” interface

Turn Off BT?
Yes **No**

Figure 15 Bluetooth “OFF” interface

5.5.6 Exit main menu

Under main menu, press the “menu button” to exit the main menu and return to the measurement interface.

5.6 Data upload

A. Wired transmission

Connect the device to the computer by the USB cable, upload the data after connecting the PC software properly, refer to “Software operating instruction” for details.



The PC software can be downloaded from our official website

B. Bluetooth transmission (Bluetooth equipment)

Turn on the device Bluetooth and the PC software to upload data, refer to “Software operating instruction” for details.

5.7 Power off

Long press the “power on/off” button, until the device turns off.



When the device is in storing, it can't be turned off.

6 MAINTAIN, TRANSPORT AND STORAGE

6.1 Cleaning and disinfection

The device must be turned off before cleaning, and it should not be immersed into liquid.

Please take out the internal battery before cleaning, do not immerse it into liquid.

Use 75% alcohol to wipe the device enclosure, and use liquid soap or isopropanol to wipe the watchband for disinfection, nature dry or clean it with clean and soft cloth. Do not spray any liquid on the device directly, and avoid liquid penetrating into the device.

6.2 Maintenance

- A. Check the main unit and all accessories periodically to make sure that there is no visible damage that may affect patient's safety and monitoring performance. It is recommended that the device should be inspected weekly at least. When there is obvious damage, stop using it.
- B. Please clean and disinfect the device before/after using it according to the User Manual (6.1).
- C. Please replace the batteries in time when low-battery appears.
- D. Please take out the batteries if the device is not used for a long time.
- E. The device need not to be calibrated during maintenance.











6.3 Transport and Storage























- A. The packed device can be transported by ordinary conveyance or according to transport contract. During transportation, avoid strong shock, vibration and splashing with rain or snow, and it can not be transported mixed with toxic, harmful, corrosive material.
- B. The packed device should be stored in room with no corrosive gases and good ventilation. Temperature: $-40^{\circ}\text{C}\sim+60^{\circ}\text{C}$; Relative humidity: $\leq 95\%$.

7 TROUBLESHOOTING

Trouble	Possible Reason	Solution
The values can not be displayed normally or stably.	<ol style="list-style-type: none"> 1) The finger is not properly inserted. 2) The finger is shaking or the patient is moving. 3) The device is not used in environment required by the manual. 4) The device works abnormally. 	<ol style="list-style-type: none"> 1) Please insert the finger properly and measure again. 2) Let the patient keep calm. 3) Please use the device in normal environment. 4) Please contact the after-sales.
The device can not be turned on	<ol style="list-style-type: none"> 1) The battery is drained away or almost drained away. 2) The battery is installed incorrectly. 3) The device's malfunction. 	<ol style="list-style-type: none"> 1) Please change batteries. 2) Please Install the battery again. 3) Please contact the local service center.
The display disappears suddenly.	<ol style="list-style-type: none"> 1) The device enters into the energy saving mode. 2) Low battery. 3) The device works abnormally. 	<ol style="list-style-type: none"> 1) Normal. 2) Please charge the battery. 3) Please contact the after-sales.
The data can not be stored.	<ol style="list-style-type: none"> 1) The device is not operated according to the manual. 2) The device works abnormally. 	<ol style="list-style-type: none"> 1) Please operate the device according to the manual. 2) Please contact the after-sales.

8 KEY OF SYMBOLS

Signal	Description	Signal	Description
	Follow instructions for use		Left button/Alarm pause button
%SpO ₂	The pulse oxygen saturation (%)		Menu button
PR bpm	Pulse rate (bpm)		Right button/clock button
	Close the alarm sound indication		Down button
	Pause the alarm sound indication		Up button/replay button
	Open the alarm sound indication		USB

	Close the pulse sound indication		Type BF applied part
	Open the pulse sound indication		Serial number
Finger Out	1. The finger clip falls off (no finger inserted) 2. Probe error		1. The finger clip falls off (no finger inserted) 2. Probe error 3. Signal inadequacy indicator
	The battery power is full		Two grid of the battery
	One grid of the battery		The lack of battery power. (Please change batteries in time for exact measuring)
	Alarm inhibit		Manufacturer
	Power on/off button		Date of manufacture
+	Battery positive electrode		Battery cathode
	Temperature limit		Atmospheric pressure limit
	Humidity limit		This side up
	Fragile, handle with care		Keep in a cool, dry place
IP22	Covering Protection rate		Recyclable
	Bluetooth: ON (Bluetooth equipment)		WEEE disposal
CE	Medical Device complies with Directive 93/42/EEC	REC● Recording	Record state
	Caution: read instructions (warnings) carefully		Keep away from sunlight
REF	Product code	LOT	Lot number
UK REP	Authorized Representative in the UK	CH REP	Authorized Representative in Swiss

Note: Your device may not contain all the following symbols.

9 SPECIFICATION

SpO2 [see note 1]	
Display range	0% ~ 99%
Measured range	0% ~ 100%
Accuracy [see note 2]	70%~100%: ±2%; 0%~69%: unspecified.
Resolution	1%

PR	
Display range	30 bpm ~ 250 bpm
Measured range	30 bpm ~ 250 bpm
Accuracy	±2 bpm or ±2%, whichever is greater.
Resolution	1 bpm
Accuracy under low perfusion [see note 3]	Low perfusion 0.4%: SpO2: ±4%; PR: ±2 bpm or ±2%, whichever is greater
Light interference	Under normal and ambient light conditions, the SpO2 deviation ≤ 1%
Pulse intensity	Continuous bar graph display, the higher display indicates the stronger pulse.
Upper and lower limit of measured values	
SpO2	0% ~ 100%
PR	0 bpm ~ 254 bpm
Optical sensor [see note 4]	
Red light	Wavelength: about 660 nm, optical output power: < 6.65 mW
Infrared light	Wavelength: about 905 nm, optical output power: < 6.75 mW
Memory	Up to 99 group of data under auto mode, total duration does not exceed 72 hours. Up to 24-hour data under manual mode.
Safety class	Internally powered equipment, type BF applied part
International Protection	IP22
Working voltage	DC 2.6 V ~ 3.6V
Working current	≤ 100 mA
Power supply	Dry battery (2AA)
Dimension and Weight	
Dimensions	110(L) × 60(W) × 24(H) mm
Weight	About 120g (with Dry battery(2AA))
<p>Note 1: the claims of SpO2 accuracy shall be supported by clinical study measurements taken over the full range. By artificial inducing, get the stable oxygen level to the range of 70 % to 100 % SpO2, compare the SpO2 values collected by the secondary standard pulse oximeter equipment and the tested equipment at the same time, to form paired data, which are used for the accuracy analysis.(It is applicable for the probes equipped There are 12 healthy volunteers (male: 6, female: 6; age: 21~29; skin color: black: 4, light: 7, white: 1) data in the clinical report.</p> <p>Note 2: because pulse oximeter equipment measurements are statistically distributed, only about two-thirds of pulse oximeter equipment measurements can be expected to fall within ±Arms of the value measured by a CO-OXIMETER.</p> <p>Note 3: percentage modulation of infrared signal as the indication of pulsating signal strength, patient simulator has been used to verify its accuracy under conditions of low perfusion. SpO2 and PR values are different due to low signal conditions, compare them with the known SpO2 and PR values of input signal.</p> <p>Note 4: optical sensors as the light-emitting components, will affect other medical devices applied the wavelength range. The information may be useful for the clinicians who carry out the optical treatment.For example, photodynamic therapy operated by clinician.</p> <p>Note 5: Patient simulator has been used to verify the pulse rate accuracy, it is stated as the root-mean-square difference between the PR measurement value and the value set by simulator.</p>	

EMC

Note:

- The device is subject to special EMC precautions and it must be installed and used in accordance with these guidelines.
- The electromagnetic field can affect the device performance, so other equipment used near the device must meet the corresponding EMC requirements. Mobile phones, X-rays or MRI devices are possible interference source, as they can emit high-intensity electromagnetic radiation.

- Refer to above chapters for the minimum value of user’s physiological signal. Inaccurate result will appear when the device operates with the values lower than the descriptions in above chapter
- The use of ACCESSORIES, transducers and cables other than those specified, with the exception of transducers and cables sold by the MANUFACTURER of the ME EQUIPMENT or ME SYSTEM as replacement parts for internal components, may result in increased EMISSIONS or decreased IMMUNITY of the ME EQUIPMENT or ME SYSTEM.
- The device should not be used adjacent to or stacked with other equipment and that if adjacent or stacked use is necessary, it should be observed to verify normal operation in the configuration in which it will be used.
- Devices or systems may still be interfered by other equipment, even if other equipment meets the requirements of the corresponding national standard.
- Basic performance: SpO2 measured range: 70% ~ 100%, absolute error: ±2%; PR measured range: 30 bpm ~ 250 bpm, accuracy: ±2 bpm or ±2%, whichever is greater.

The following cable types must be used to ensure that they comply with interference radiation and immunity standards:

N.	Name	Cable length(m)	Shielding or not	Remark
1	USB cable	1,0	Yes	
2	SpO2 probe	1,5	No	

Appendix 1

State	Prompt condition delay	Prompt signal generation delay
Low voltage prompt	1 s	20 ms
SpO2 prompt	330 ms	20 ms
Pulse rate prompt	330 ms	20 ms
Probe error prompt	16 ms	20 ms

Appendix 2

Guidance and manufacture’s declaration – electromagnetic emissions-for all EQUIPMENT and SYSTEMS

Guidance and manufacture’s declaration – electromagnetic emission		
The Pulse Oximeter is intended for use in the electromagnetic environment specified below. The customer of the user of the Pulse Oximeter should assure that it is used in such and environment.		
Emission test	Compliance	Electromagnetic environment – guidance
RF emissions CISPR 11	Group 1	The Pulse Oximeter uses RF energy only for its internal function. Therefore, its RF emissions are very low and are not likely to cause any interference in nearby electronic equipment.
RF emissions CISPR 11	Class B	The Pulse Oximeter is suitable for use in all establishments, including domestic establishments and those directly connected to the public low-voltage power supply network that supplies buildings used for domestic purposes.

Guidance and manufacture’s declaration – electromagnetic immunity –for all EQUIPMENT and SYSTEMS

Guidance and manufacture’s declaration – electromagnetic immunity			
The Pulse Oximeter is intended for use in the electromagnetic environment specified below. The customer or the user of Pulse Oximeter should assure that it is used in such an environment.			
Immunity test	IEC 60601 test level	Compliance level	Electromagnetic environment - guidance

Electrostatic discharge (ESD) IEC 61000-4-2	8 kV contact 15 kV air	8 kV contact 15 kV air	Floors should be wood, concrete or ceramic tile. If floor are covered with synthetic material, the relative humidity should be at least 30%. the manufacturer may recommend the ESD precautionary procedures to user.
Power frequency (50Hz) magnetic field IEC 61000-4-8	30 A/m	30 A/m	Power frequency magnetic fields should be at levels characteristic of a typical location in a typical commercial or hospital environment.

Guidance and manufacture's declaration – electromagnetic immunity – for EQUIPMENT and SYSTEMS that are not LIFE-SUPPORTING

Guidance and manufacture's declaration – electromagnetic immunity			
The Pulse Oximeter is intended for use in the electromagnetic environment specified below. The customer or the user of Pulse Oximeter should assure that it is used in such an environment.			
Immunity test	IEC 60601 test level	Compliance level	Electromagnetic environment - guidance
Conducted RF IEC 61000-4-6	3V (0.15MHz–80MHz), 6V (in ISM bands between 0.15MHz and 80MHz)	3V (0.15MHz–80MHz), 6V (in ISM bands between 0.15MHz and 80MHz)	Portable and mobile RF communications equipment should be used no closer to any part of the Pulse Oximeter, including cables, than the recommended separation distance calculated from the equation applicable to the frequency of the transmitter. Recommended separation distance $d = \left[\frac{3.5}{r} \right] \sqrt{P}$ $d = \left[\frac{3.5}{E} \right] \sqrt{P} \quad 80 \text{ MHz to } 800 \text{ MHz}$ $d = \left[\frac{7}{E} \right] \sqrt{P} \quad 800 \text{ MHz to } 2,7 \text{ GHz}$ <p>Where P is the maximum output power rating of the transmitter in watts (W) according to the transmitter manufacturer and d is the recommended separation distance in metres (m).</p> <p>Field strengths from fixed RF transmitters, as determined by an electromagnetic site survey,^a should be less than the compliance level in each frequency range.^b</p> <p>Interference may occur in the vicinity of equipment marked with the following symbol:</p> 
Radiated RF IEC 61000-4-3	10 V/m 80 MHz to 2.7GH	10 V/m	
<p>NOTA 1 At 80 MHz and 800 MHz, the higher frequency range applies.</p> <p>NOTE 2 These guidelines may not apply in all situations. Electromagnetic propagation is affected by absorption and reflection from structures, objects and people.</p>			
<p>a Field strengths from fixed transmitters, such as base stations for radio (cellular/cordless) telephones and land mobile radios, amateur radio, AM and FM radio broadcast and TV broadcast cannot be predicted theoretically with accuracy. To assess the electromagnetic environment due to fixed RF transmitters, an electromagnetic site survey should be considered. If the measured field strength in the location in which the Pulse Oximeter is used exceeds the applicable RF compliance level above, the Pulse Oximeter should be observed to verify normal operation. If abnormal performance is observed, additional measures may be necessary, such as reorienting or relocating the Pulse Oximeter.</p> <p>b Over the frequency range 150 kHz to 80 MHz, field strengths should be less than 3 V/m.</p>			

Recommended separation distances between portable and mobile RF communications equipment and the EQUIPMENT or SYSTEM – for EQUIPMENT or SYSTEM that are not LIFE-SUPPORTING

Recommended separation distances between portable and mobile RF communications equipment and the Pulse Oximeter.

The Pulse Oximeter is intended for use in an electromagnetic environment in which radiated RF disturbances are controlled. The customer or the user of the Pulse Oximeter can help prevent electromagnetic interference by maintaining a minimum distance between portable and mobile RF communications equipment (transmitters) and the Pulse Oximeter as recommended below, according to the maximum output power of the communications equipment.

Rated maximum output power of transmitter (W)	Separation distance according to frequency of transmitter (m)		
	150 kHz to 80 MHz $d = \left[\frac{3,5}{f^{1,1}} \right] \sqrt{P}$	80 MHz to 800 MHz $d = \left[\frac{3,5}{E^{1,1}} \right] \sqrt{P}$	800 MHz to 2,7 GHz $d = \left[\frac{7}{E^{1,1}} \right] \sqrt{P}$
0,01	0,058	0,035	0,07
0,1	0,18	0,11	0,22
1	0,58	0,35	0,7
10	1,83	1,10	2,21
100	5,8	3,5	7

For transmitters rated at a maximum output power not listed above, the recommended separation distance d in metres (m) can be estimated using the equation applicable to the frequency of the transmitter, where P is the maximum output power rating of the transmitter in watts (W) according to the transmitter manufacturer.

NOTE 1 At 80 MHz and 800 MHz, the separation distance for the higher frequency range applies.

NOTE 2 These guidelines may not apply in all situations. Electromagnetic propagation is affected by absorption and reflection from structures, objects and people.



Disposal: *The product must not be disposed of along with other domestic waste. The users must dispose of this equipment by bringing it to a specific recycling point for electric and electronic equipment.*

GIMA WARRANTY TERMS

The Gima 12-month standard B2B warranty applies.