



GIMA

PROFESSIONAL MEDICAL PRODUCTS

SOLLEVATORE ELETTRICO CON IMBRACATURA

ELECTRIC LIFT WITH HARNESS

LÈVE-PERSONNE ÉLECTRIQUE AVEC HARNAIS

ELEVADOR ELÉCTRICO CON ARNÉS

ELEVADOR ELÉTRICO COM ARNÊS

LIFT ELECTRIC CU HAM

ELLYFT MED SELE

ELEKTRIČNA DIZALICA S REMENOM

È necessario segnalare qualsiasi incidente grave verificatosi in relazione al dispositivo medico da noi fornito al fabbricante e all'autorità competente dello Stato membro in cui si ha sede.

All serious accidents concerning the medical device supplied by us must be reported to the manufacturer and competent authority of the member state where your registered office is located.

Il est nécessaire de signaler tout accident grave survenu et lié au dispositif médical que nous avons livré au fabricant et à l'autorité compétente de l'état membre où on a le siège social.

Es necesario informar al fabricante y a la autoridad competente del Estado miembro en el que se encuentra la sede sobre cualquier incidente grave que haya ocurrido en relación con el producto sanitario que le hemos suministrado

É necessário notificar ao fabricante e às autoridades competentes do Estado-membro onde ele está sediado qualquer acidente grave verificado em relação ao dispositivo médico fornecido por nós

Orice accident grav produs, privitor la dispozitivul medical fabricat de firma noastră, trebuie semnalat producătorului și autorității competente în statul membru pe teritoriul căruia își are sediul utilizatorul

Det är nödvändigt att meddela tillverkaren och de behöriga myndigheterna i den berörda medlemsstaten, om alla allvarliga olyckor som inträffat i samband med den medicintekniska utrustning som levererats av oss

Potrebno je prijaviti svaku ozbiljnu nezgodu koja se dogodila u vezi s isporučenim medicinskim proizvođaču i nadležnom tijelu države članice u kojoj se nalazi

GIMA 43455



Mingguang Longway Technology Co., Ltd.
No. 59 Lingji Rd., Industrial Park, Mingguang, Anhui, China
Made in China



LW06206



Lotus NL B.V. Koningin Julianaplein 10, 1 e Verd, 2595AA, The Hague, Netherlands



Gima S.p.A.
Via Marconi, 1 - 20060 Gessate (MI) Italy
gima@gimaitaly.com - export@gimaitaly.com
www.gimaitaly.com





1 SAFETY WARNINGS





1.1 General warnings

- ⚠ The instruction manual is an integral part of the delivery, must be kept with care and available for immediate consultation.
- ⚠ This document is intended for the owner, security managers, users, maintenance workers and must be transferred in case of any transfers.
- ⚠ The manual provides information on the correct use of a lift, on the technical characteristics and on safety precautions. However, he can never fill the lack of experience.
- ⚠ If transport damage is noted upon receipt, the device should not be used. You should contact technical support for verification and inspection of the device.
- ⚠ The device must be used by persons who can physically control the strength of the device or the weight of the person being carried.
- ⚠ The conductor of the device must be aware of and have fully understood the contents of the manual.
- ⚠ Before each use, always check the efficiency of the brake components and safety in general.
- ⚠ The conductor must keep both hands firmly on the handlebars.
- ⚠ The device must be used in accordance with the following requirements:
 - Holder older than 18 years.
 - Do not use the aid as a means of transporting different objects.
 - Other different items or extra weights must not be carried with the person.
 - The driver must never leave the lift while a person is on board.
 - Do not use the device on uneven surfaces.
- ⚠ The device is not intended for use by persons (including children) whose physical, sensory or mental capacities are impaired or lacking experience or knowledge, unless they have been able to benefit from it through a person responsible for their safety, supervision or instructions for use of the device.
- ⚠ Persons transported and drivers must not smoke to prevent damage or fire to clothing, coverings or in any case damage to persons.
- ⚠ The conductors of the device must hold the handlebars with both hands to ensure constant control of the lift.
- ⚠ Assembly and adjustments must only be carried out by authorized personnel.
- ⚠ Never lift the device with the person on board.
- ⚠ The device cannot be used in exposure to water splashes or adverse weather conditions.
- ⚠ The handler and the patient should be careful not to wear long scarves or slow clothes; These can become entangled and constitute a source of danger.
- ⚠ Before using the aid, make sure that the weight of the person being transported does not exceed the maximum permissible load capacity. This value is shown on the lifting arm.
- ⚠ The lift is intended to lift and transfer disabled people from bed to wheelchair and vice versa, it should not be used to transport the person from one room to another.
- ⚠ The lift is a gentle aid, therefore it should not be used for uses other than those for which it was designed.
- ⚠ Any serious incident that has occurred in relation to the device shall be reported to the manufacturer and the competent authority of the Member State in which the user and/or the patient is established

1.2 Symbols used

In the manual can be found the following symbols.

	Operation must be carried out by qualified personnel only or an assistance centre.
	Read the instruction manual

	Operation that must be done by two persons
	Warning! Danger
	Warning! Important information
	Use protective gloves

The manufacturer reserves the right to make any changes to the product and its instruction manual without prior notice or updating of previous productions.

The manufacturer is relieved of any responsibility for damages resulting from improper use by untrained personnel, from unauthorized modifications or interventions, from the use of unauthorized spare parts, from exceptional events, from total non-compliance with the instructions contained in this manual.

2. OPENING THE PACKAGE

- When using a cart to move the packaged product, take special care to avoid rollover injuries.
- Open the package and remove the contents carefully, taking care not to damage it.
- After unpacking the device make sure that it is not damaged.
- Any damage must be reported to the carrier within 24 hours.

2.1 Tips for protecting the environment

The packaging is 100% recyclable. For disposal follow local regulations. Packaging material (plastic bags, polystyrene elements, etc.) must be kept out of the reach of children as a potential source of danger.

Pursuant to Article 13 of Legislative Decree no. 151 of 25 July it is recommended to follow the following general warning

- The crossed-out bin symbol on the equipment or its packaging indicates that the product must be collected separately from other waste at the end of its useful life.
- The user who wants to get rid of this device must therefore contact the local company in charge of waste disposal and follow the system that this adopts to implement its disposal.
- Adequate separate collection for the subsequent disposal of discarded equipment for recycling, environmentally friendly treatment and disposal help to avoid possible negative effects on the environment and health and promotes the reuse and/or recycling of materials.
- The illegal disposal of the product involves the application of administrative penalties provided for by current legislation.

3. DESCRIPTION

The electric lift LW06206 allows a person to be lifted by the action of the linear actuator for transfers (eg. from the bed to a wheelchair). The operation takes place through the use of a fabric harness equipped with hooking straps.

3.1 Product illustration

1. Base
2. Front wheels
3. Rear wheels with brake
4. Column
5. Lifting arm
6. Balance
7. Open base system
8. Handle
9. Control unit with battery and internal charger
10. Safety ring
11. Linear actuator
12. Leg opening pedals



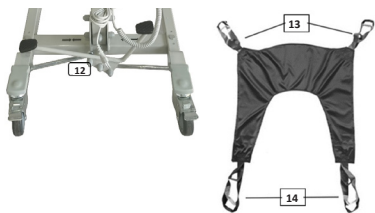

The device is supplied as standard with a standard medium-sized harness
13. fixing rings to the head side support
14. fixing rings to the leg side support

4. ASSEMBLY

The device must be fitted and tested before use by qualified personnel.
 These operations must be carried out by qualified personnel

4.1 Chassis assembly

Remove all parts from the package.

Place the load-bearing column vertically (2) with respect to the base (1) and secure it in position with the supplied bolt (3). Using a key M19, and the removable pin (4), then tighten the bolt (3).

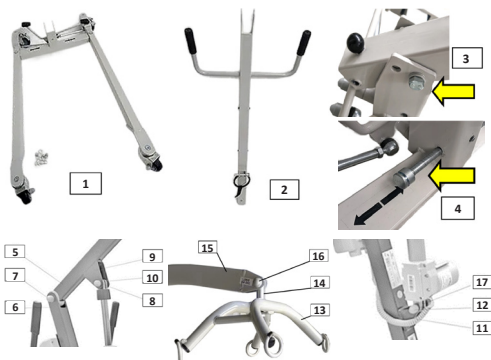

Insert the arm (5) into the relevant flange (6) at the top of the carrier column and secure it in place using the supplied bolt and nut (7). Tighten the bolt and nut using an M17 wrench.

Insert the upper end of the electric actuator (8) into the flange on the upper arm (9) and secure it in place using the supplied bolt and nut (10). Tighten the bolt and nut using an M17 wrench.

Insert the lower end of the electric actuator (17) into the appropriate flange (11) and secure it using the supplied bolt (12). Tighten the bolt and nut using an M17 wrench.

Insert the pivot pin (14) of the attachment crutch (13) into the seat at the end of the lifting arm (15) and anchor it using the supplied bolt (16). Tighten the bolt and nut with an M17 wrench.

4.2 Installation of the electrical system

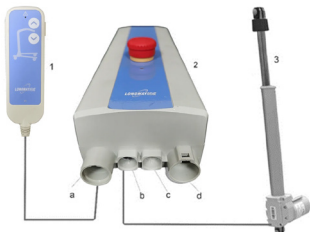

Proceed as follows:

Connect the motor cable (3) into connector (b) of the control unit (2),

Connect the push-button panel cable (1) into the connector (a) of the control unit (2),

NOTE: The connector (c) is not used in this version of the linkage

5 SPECIFICATIONS

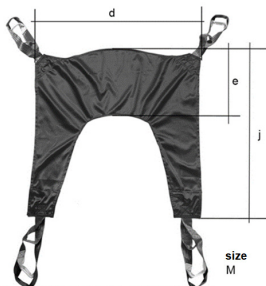
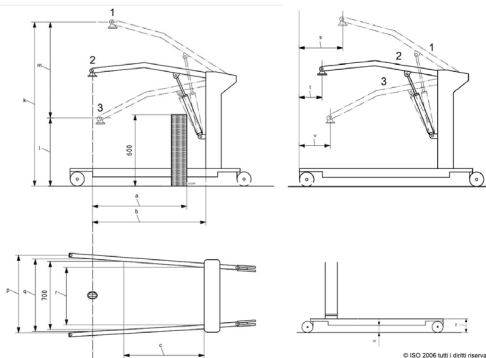

Material: 100% Polyester

size M

	Description	Mm
1	Highest position	1870
2	location at maximum distance	1610
3	lowest position	440
a	maximum distance to 600 mm	610
b	maximum distance from the base.	610
c	Distance from the base with open legs to 700 mm.	800
k	maximum CSP height.	1870
i	minimum CSP height.	440
m	Lifting excursion	1430
p	maximum internal width	720
q	internal width at maximum distance	670
r	minimum internal width	480
s	minimum distance from the wall to the CSO at maximum height (legs apart)	560
t	minimum distance from the wall to the CSO to the maximum extension (legs apart)	220
v	minimum distance from the wall to the CSO at the minimum height (legs apart)	560
y	Base height	115

w	free space under the legs	50
d	total width	920
e	back band height	560
j	total length	1050

Technical Specifications		
Weight (kg)		37
Capacity (kg)		150
Front wheel diameter (mm)		75
Rear wheel diameter with parking brake (mm)		100
Rotation radius 360° (mm)		1260
Internal power supply battery (lead gel)		24 V dc (2x12 Vdc) - 2.9 Ah
Power supply for battery charging		100-240 Vac - 50/60 Hz
Number of lifting cycles with battery in full efficiency and initial charge over 90%	Load = 150 kg	30
Average battery charging time less than 10% charge (h)		4
Ambient temperature range of use (C°)		0 ÷ 45
Storage temperature in dry environment (C°)		-10 ÷ 40
Package dimensions W x D x H (mm)		670 x 1160 x 260
Weight with packaging (kg)		42
Sound level (dB)		< 70

6. INTENDED USE

6.1 Intended use

The use of the device is allowed only on condition that all safety elements and functional parts are efficient.

- The lift is intended for lifting and transferring disabled people (for example from bed to wheelchair and vice versa); it cannot be used to transfer the person from one room to another.
- The lift is a specific aid, therefore it must not be used for uses other than those for which it was designed.

The aid can only be handled on flat surfaces with a stable bottom.

The use is exclusively that described in this manual. It is therefore advisable to read these instructions carefully to become familiar with the functionality of the device.

6.2 Prohibition of use

Cannot be used to lift objects other than people
 Cannot be used if the person's weight exceeds the maximum permissible load capacity (150 kg)
 It cannot be used if the size or pathology of the subject to be lifted is not well secured to the harness provided.

It cannot be used by conductors who, due to their physical structure and attitude, may have difficulty controlling the weight of the person and the lifter. It cannot be used in environments subject to splashing water or critical or unfavorable weather conditions.

Furthermore, it should not be used in all cases where the principles described in Chapter 2 are not adhered to.

It should not be used if defects or faults are found that could generate unforeseeable dangerous situations.

6.3 Residual risks

Risk of crushing of the feet of the personnel assigned if the requirements of this manual are not adopted.

Risk of entrapment of loose, slow clothing reaching the bottom of the

assistive device.

Risk of falling the patient if all necessary precautions are not taken to conduct the device and maintain a vertical and stable position.

7 USE

- ⚠ Before daily use of the device, always check the status and overall efficiency of the aid and the battery charge.

7.1 Charging the battery

The control unit is equipped with a connector for the battery charging cable (supplied) indicated in the yellow circled area of the control unit.



Charging indications

The battery should only be charged using the supplied cable.

Avoid using extension cords, adapters or other devices.

The battery charge status is directly visible on the control unit in the LCD display. Batteries do not require maintenance. Connect the connector to the socket on the control unit.

Connect the charger plug to the mains.

Charging the battery from low charge or completely discharged state takes about 4 hours.

If the device is to remain unused for a long period of time (over a month) it is necessary to recharge the battery every month.



7.2 Lifting function

• Make sure the battery is fully charged.

- Make sure the safety button is unlocked. (turning it counterclockwise)
- Press the button on the remote control to operate the lift.
- The movement control can also be carried out via the 2 buttons on the main control unit body next to the battery display



7.3 Function of the safety ring

Faced with potential malfunctions of the electrical group of the machine, or critical situations such as unexpected stops due to a low battery, it is possible to adjust the height of the lifting arm and consequently of its rocker, simply by acting on the appropriate safety ring placed at the end of the linear actuator.

The red knob (a) located at the top of the actuator can be manually moved downwards by passing it from the position fig. 1

to that of fig. 2, at this point it is possible to rotate it manually thus activating the manual ascent or descent of the lifting arm, the lift is also equipped with safety against accidental crushing due to the arm of the device, in practice if the lifting arm encounters during its motorized movement downwards an obstacle in order to avoid causing damage to people or things automatically it will be brought to the position referred to in figure 2 and always automatically stop pushing down (the actuator motor even if the control button is pressed for the descent movement will run empty)

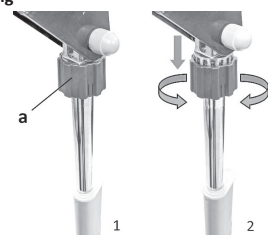

7.4 Use of harnesses

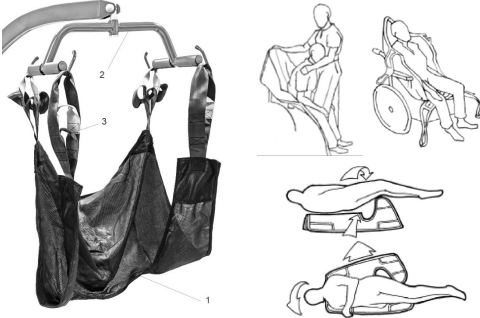

For the use of the supplied universal harness (not suitable for patients without head control) refer to the following procedure:

- Apply the harness (1) to the patient or disabled person. (the drawings below are purely indicative of the application to lying patient or sitting patient)
- Lower the lift arm to the desired level.
- Attach the harness (1) to the harness support barbell hooks (2) and lift the patient.

Before lifting, adapt the harness (1) to the needs of the patient, appropriately choosing the slots (3) identified by 3 different colors for each of them to be attached to the hooks.

A different color scheme of the attachment ring between the head side and the leg side of the harness will result in a different inclination and position of the patient when lifted.

position	Leg's fixed ringbelt	Head's fixed ringbelt
	BLUE	RED
	BLUE	YELLOW
	BLUE	BLUE
	YELLOW	BLUE

7.5 Opening the base of the lift

The spread of the base of the lift takes place by means of a special pedal system located in the back, press the pedal (A) to open, press the pedal (B) to close.

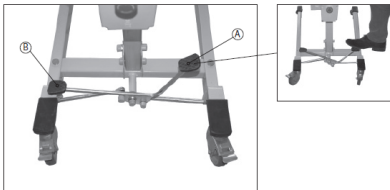

7.6 Lifting bend

To bend the lift, proceed as follows: lower the lift arm to the maximum by means of the electric control

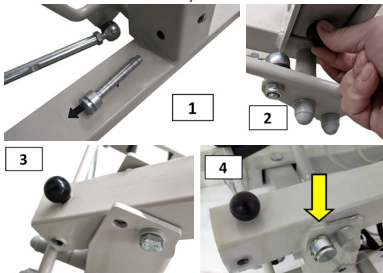

Then proceed to extract the locking pin (1), supporting the riser column then release the folding outlet knob (2) pulling it, then bend the riser forward (3) upon reaching the horizontal position of the column insert the locking pin in the indicated position (4) to fix the riser column in the bent position.

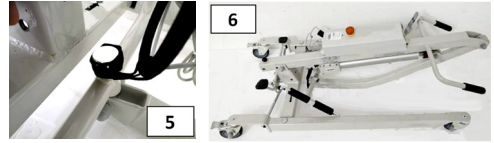

Attach the elastic strap to the basket pin (5)

The lift will appear as in (6)

To reopen the lift, follow the bending procedure described above.

8. ORDINARY MAINTENANCE

The lift needs routine maintenance like any other product, this to keep it in perfect conditions of efficiency, even after years of use.

Remove dirt and any elements that may accumulate every day. You can use a household vacuum cleaner.

Below you will find a table with an indication of how often to perform maintenance operations.

Table of ordinary maintenance

Frequency:	
Semiannual	Cleaning of metal parts Clean these parts according to use and need Cleaning of plastic parts Clean these parts according to use and need Wheel cleaning Clean these parts as per use and need
Bimonthly	Lubrication Depending on use and needs
Annual	General control Check the wheels and tighten thebolts Check the braking system Check that the paint is rusty or chipped Check that plastic parts are intact and state of wear, replace if required Check that the electric motors are working properly and lubricate the sliding screws
Semiannual	Battery Check that the battery charging time is not too long, otherwise contact the technical support service.
Transfer to third parties or restoration	Disinfection Attention! Disinfectants should only be used by specially qualified personnel. Disinfection of this device must be carried out by specialized centers according to the provisions of the competent health authority. For more information, contact your authorized technical service provider.

8.1 Cleaning of metal parts

Painted metal parts can be cleaned with commercial household sprays, but be careful that they do not contain alcohol or solvents that can discolor or damage the paint itself.

Chrome parts can be cleaned with ordinary household products and then dried well. Do not use direct water jets or splashes.

8.2 Cleaning of plastic parts

For cleaning plastic parts, use a special detergent for commercial plastic following the instructions and contraindications provided in the instructions for use of the product. Avoid solvents or products containing alcohol.

Do not use direct water jets or splashes.

8.3 Wheel cleaning

Periodically clean the wheels, including depending on the type of environment in which the device is used.





Remove from the surfaces any solid parts that may get stuck in the rubber,

wires and hair that could be wrapped around the hub making it difficult to rotate.

Clean the locking mechanism using a toothbrush.

9. TROUBLESHOOTING

Component	Inconvenience	Solution
Wheel	Squeak during movement	Wheel cleaning Lubricating wheels Replace wheels
	Low battery	Check the charger, charging if necessary
	Safety button pressed	Unlock the button
	Actuator/remote control/ control unit connection cables are not connected correctly	Check electrical connections Check the operation of electrical components
Battery	Battery doesn't charge normally, takes too long, or doesn't fully charge	Check the electrical integrity of the control unit Check the integrity and connection mode of the connection between machine and mains current
	The battery has a limit of refills	

	Medical device
	Keep away from sunlight
	Keep in a cool, dry place
	Imported by
	Temperature limit

GIMA WARRANTY TERMS









The Gima 12-month standard B2B warranty applies.

 **Disposal:** *The product must not be disposed of along with other domestic waste. The users must dispose of this equipment by bringing it to a specific recycling point for electric and electronic equipment.*

10. ACCESSORIES

LW06407		UNIVERSAL SLING Size: S-M-L
LW06401		Economy Sling Size: S-M-L

SYMBOL LEGEND

	Manufacturer
	Date of manufacture
	Product code
	Lot number
	Authorized representative in the European community
	Caution: read instructions (warnings) carefully
	Follow instructions for use
	Medical Device compliant with Regulation (EU) 2017/745